

1-1-2000

Special Bulletin #6: Iconographic Contents and Diagrams for Descriptive Cataloging of Complex Works of Art

Follow this and additional works at: <https://online.vraweb.org/vrab>

Part of the [Ancient, Medieval, Renaissance and Baroque Art and Architecture Commons](#)

Recommended Citation

(2000) "Special Bulletin #6: Iconographic Contents and Diagrams for Descriptive Cataloging of Complex Works of Art," *VRA Bulletin*:Vol. 27: Iss. 1, Article 1.

Available at: <https://online.vraweb.org/vrab/vol27/iss1/1>

This Feature Articles is brought to you for free and open access by VRA Online. It has been accepted for inclusion in VRA Bulletin by an authorized editor of VRA Online.

Special Bulletin #6: Iconographic Contents and Diagrams for Descriptive Cataloging of Complex Works of Art

Abstract

This publication gathers diagrams and cataloging descriptions in order to produce consistent content descriptions for complex iconographic cycles to facilitate logical and easy-to-browse shelving arrangements. The purpose is to create a guide that will provide iconographic contents, as well as diagrams of the physical arrangements, for these works of art to assist with the development of more accurate and consistent catalog records for the images in these compositions.

This publication includes identifying information on cycles and altarpieces, including for the Brancacci Chapel, the Baptistry Doors in Florence, the Ghent Altarpiece, and the niches at Orsanmichele, to name a few.

Keywords

diagrams, cataloging, metadata, mapping, altarpiece, iconography

Author Bio & Acknowledgements

Nancy Shelby Schuller - University of Texas - Austin

Marlene E. Gordon - University of Michigan - Dearborn

Elizabeth Spungen - Bryn Mawr College Libraries

Graphic design and layout: F. Terry Arzola - Austin Community College

VRA Publications Advisory Committee:

Linda Callahan - Mount Holyoke College

Chair: Sheryl Frisch - California Polytechnic University

Marlene Gordon - University of Michigan - Dearborn

Louise Kulp - Franklin and Marshall College

Linda McRae - University of South Florida

Elizabeth O'Donnell - Dartmouth College

Jenni Rodda - New York University

Lilla Sweatt - San Diego State University

Susan Thalmann - Pomona College

Debra Winters - California State University - Fullerton

Visual Resources Association Special Bulletin No. 6

**Iconographic Contents and Diagrams for
Descriptive Cataloging of Complex
Works of Art**

**Nancy Shelby Schuller
Visual Resources Curator
and
Senior Lecturer
Department of Art and Art History
The University of Texas–Austin**

with

**Marlene E. Gordon
Senior Associate Curator
Humanities Department
University of Michigan–Dearborn**

**Elizabeth Spungen
Slide Librarian (former)
Visual Resources Division
Bryn Mawr College Libraries**

**Graphic Design and Layout
F. Terry Arzola
Instructional Development Specialist
Learning Resources Center
Austin Community College**

**Visual Resources Association
2000**

Copyright 2000 Visual Resources Association. All rights reserved.

ISSN 1050-138X

Cover Diagram: Giovanni Bellini's *Polyptych of St. Vincent Ferrer*, Church of Sts. Giovanni e Paolo, Venice, late 1460s to early 1470s.

2000 VRA Publications Advisory Committee: Linda Callahan (Mount Holyoke College), Sheryl Frisch, Chair (California Polytechnic University), Marlene Gordon (University of Michigan–Dearborn), Louise Kulp (Franklin and Marshall College), Linda McRae (University of South Florida), Elizabeth O'Donnell (Dartmouth College), Jenni Rodda (Institute of Fine Arts, New York University), Lilla Sweatt (San Diego State University), Susan Thalmann (Pomona College), Debra Winters (California State University–Fullerton).

No part of this book may be reproduced in any form or by any means without written permission from the publisher, The Visual Resources Association. Contact the *VRA Bulletin* Editor, c/o Department of Art and Art History, Duke University, Durham, North Carolina 27708.

**Dedicated to
Nancy DeLaurier**

TABLE OF CONTENTS

Preface and Acknowledgments	vii
Diagrams and Lists	1
Bibliography	121
Index	129

ICONOGRAPHIC CONTENTS AND DIAGRAMS FOR DESCRIPTIVE CATALOGING OF COMPLEX WORKS OF ART

PREFACE and ACKNOWLEDGMENTS

This publication was inspired by Nancy DeLaurier, former curator of the Visual Resources Collection at the University of Missouri–Kansas City (now retired), and a primary leader in the founding of the Visual Resources Association. During our collaboration at the University of Missouri–Kansas City Summer Workshops for Slide Curators, we frequently discussed the value of sharing cataloging information. In particular, we compared and shared diagrams and catalog descriptions that each of us had gathered for producing consistent content descriptions for complex iconographic cycles to facilitate logical and easy-to-browse shelving arrangements. Just before her retirement, she mailed copies of her diagrams to me, suggesting that they might be combined with those that I had to produce a Special Bulletin for the VRA membership.

The members of the VRA Executive Board enthusiastically embraced the proposal for this publication in 1987. The purpose was to create a guide that would provide iconographic contents, as well as diagrams of the physical arrangements, for these works of art to assist with the development of more accurate and consistent catalog records for the images in these compositions.

At the time of the proposal, there were about twenty-five very rough and, in most cases, incomplete diagrams. Marlene E. Gordon (University of Michigan–Dearborn), Elizabeth Spungen (formerly Bryn Mawr College), and Leslie Walker (formerly State University of New York–Buffalo) volunteered to collaborate with me on the project. A *VRA Bulletin* announcement requesting members to submit similar materials elicited a great response. A master list was compiled of the eighty-two diagrams and lists that had been collected at this point, and the list was divided evenly among us. The plan was to draft

accurate diagrams, identifying the individual components of each work and providing citations for the references that were consulted in verifying the information.

We found that, although many of the diagrams could be completed quite easily, others required additional research. Particularly problematic were those for which the photographic documentation available was not sufficiently complete to produce an accurate diagram and some for which the iconographic identifications were incomplete or inconsistent. In addition to the committee's work and research, other VRA members continued to send diagrams that they were creating in the course of their own local cataloging. Linda Bien (Concordia University), Norine Duncan (Brown University), and Elizabeth O'Donnell (Dartmouth College) all sent useful diagrams for the guide.

About a year after we began, Leslie had a redefinition in job responsibilities and resigned from the project. In 1993, Liz Spungen resigned from the project due to ill health. Liz' contribution had already been enormous, and we are grateful for all of her work.

The rough copies of diagrams with identifications were collected at the University of Texas–Austin and re-drawn by Terry Arzola, former member of the Visual Resources Collection staff, using a computer graphics program. He is responsible for the design of the page layouts as well. In 1990, he discontinued his work on the publication and consequently those diagrams remaining to be created became my responsibility.

The descriptive information for each work comes from published sources that were available to the contributors at their own institutions or through interlibrary loan. The most current publications were utilized whenever possible. Attributions to some artists may have changed since the preparation of this Special Bulletin or may, in some cases, be in dispute. The "titles" of the works of art are, of course, only descriptions of the works and may vary depending upon the source.

Throughout the entire process of assembling these materials, as diagrams and related descriptions were completed, the responsibilities for proofreading and verifying the data and diagrams were shared among the members of the VRA Publications Advisory

Committee, as well as Marlene Gordon and myself. During the summer of 1993, Elizabeth Kocever-Widener (a graduate student in University of Texas-Austin's School of Library and Information Science) volunteered to assist with an early part of the verification process. With her superb reference skills, Elizabeth managed to locate sources that helped solve a number of identification problems.

In 1995 Marlene Gordon became Chair of the VRA Publications Advisory Committee, which assumed a greater role in the production of this publication. Members of the Committee proofread the diagrams and identifications. Although the members of the Committee have changed over the years, we are grateful for everyone's participation: Tina Bissell (formerly University of Michigan–Ann Arbor), Ann Vollman Bible (formerly Metropolitan Museum of Art), Linda Callahan (Mount Holyoke College), Sheryl Frisch (California Polytechnic State University), Colum Hourihane (Princeton University), Allan Miller (Seattle Art Museum), Linda McRae (University of South Florida), Elizabeth O'Donnell (Dartmouth College), Jenni Rodda (Institute of Fine Arts, New York University), Marty Stein (Museum of Fine Arts, Houston), Lilla Sweatt (San Diego State University), Susan K. Thalmann (Pomona College), and Debra Winters (California State University–Fullerton). Also assisting over the years were then-members of the *VRA Bulletin* staff: Joy Blouin (University of Michigan–Ann Arbor), Terry Kerby (formerly Wayne State University), Rebecca Miller-Hoort (University of Michigan–Ann Arbor), Carole J. Pawloski (Eastern Michigan University), and Janice D. Simpson (Michigan State University). The proofing has been continued by the current 2000 Publications Advisory Committee members, chaired by Sheryl Frisch.

These volunteers have been an immense help by reading through the pages for accuracy and consistency and by verifying the bibliographic citations. The advice and encouragement of Joseph Romano (former VRA President, Oberlin College), has been immensely valuable. And last, but certainly not least, a collective thanks to Mark Pompelia (*VRA Bulletin* Associate Editor, Rice University) for his design of the cover, and John

Taormina (*VRA Bulletin* Editor, Duke University) for the title page designs, preliminaries, and the final printed product.

This has been an intriguing and challenging project. The opportunity to collaborate with so many generous colleagues has been particularly rewarding. I hope that VRA members will find the finished work useful.

Nancy Shelby Schuller
Curator of Visual Resources and Senior Lecturer
Department of Art and Art History, The University of Texas–Austin

**ICONOGRAPHIC CONTENTS AND DIAGRAMS FOR DESCRIPTIVE
CATALOGING OF COMPLEX WORKS OF ART**

DIAGRAMS and LISTS

Salon Frescoes
Medici Villa
Poggio a Caiano
1519-21, first phase
1578-82, second phase

ALLORI, ALESSANDRO
ANDREA DEL SARTO
FRANCIABIGIO
PONTORMO, JACOPO

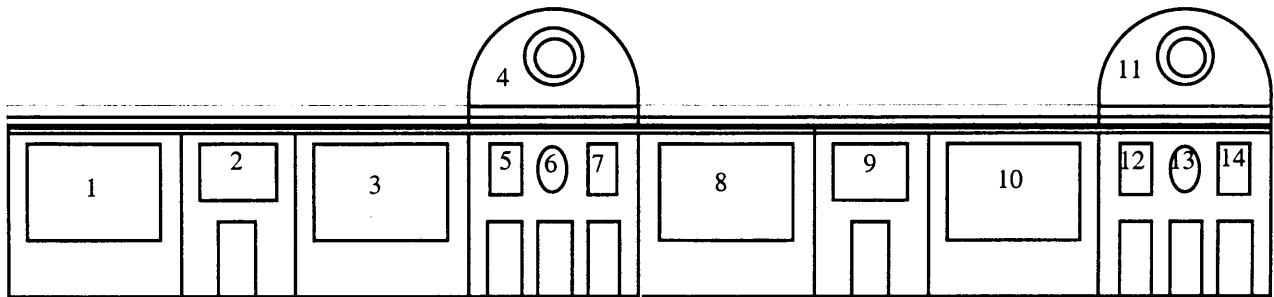

1. Allori. Siface of Numidia Receives Scipione. before 1582
2. Allori. Allegory of Magnificence/Splendor. before 1582
3. Franciabigio. Return of Cicero from Exile

4. Pontormo. Vertumnus and Pomona. 1520-21
5. Allori. Piety. 1582
6. Allori. Virtue. before 1582
7. Allori. Justice. before 1582

8. Allori. Consul Flaminio Seeks Advice of the Achei. before 1582
9. Allori. Allegory of Courage, Prudence, and Vigilance. before 1582
10. Andrea del Sarto (completed by Allori). Caesar Receiving Tributes from Egypt. 1521
11. Allori. Garden of the Hesperides. before 1582
12. Allori. Fame. before 1582
13. Allori. Glory. before 1582
14. Allori. Honor. before 1582

Source: Bardazzi, Silvestro and Eugenio Castellani. *La villa medicea di Poggio a Caiano*. 2 vols. Prato: Edizioni del Palazzo, 1981.

ALTDORFER, ALBRECHT

St. Sebastian Altarpiece
 (St. Florian Altarpiece)
 Germanisches Nationalmuseum,
 Nuremberg
 Kunsthistorisches Museum, Vienna
 c.1509-16

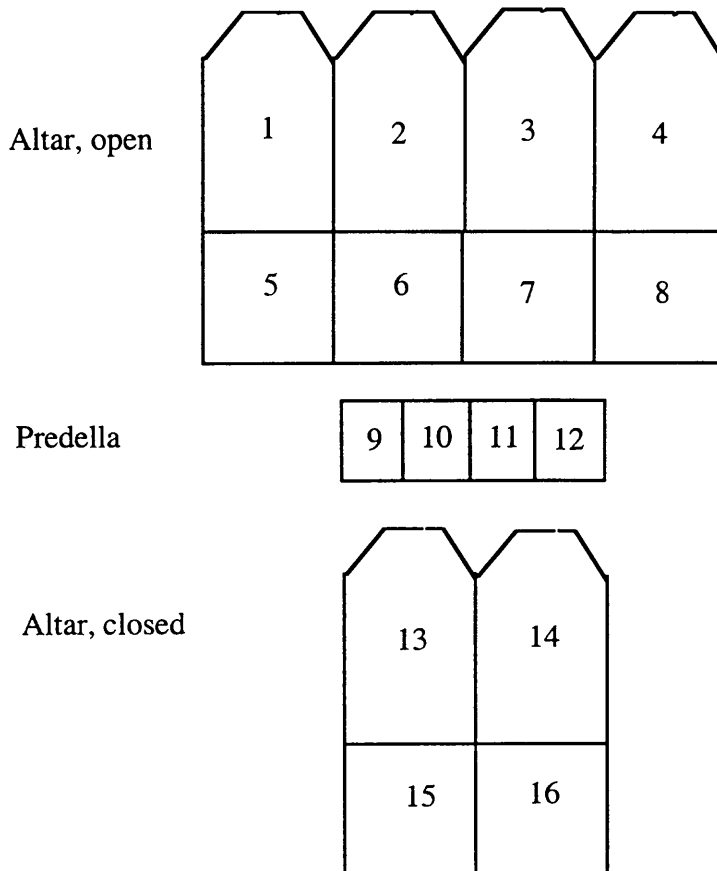

Passion of Christ

1. Agony in the Garden
2. Betrayal
3. Christ before Caiaphas
4. Flagellation
5. Crowning with Thorns
6. Pilate Washing His Hands
7. Road to Calvary
8. Crucifixion

Predella

9. Entombment
 (Vienna, Kunsthistorisches
 Museum)

10. Resurrection (Vienna,
 Kunsthistorisches Museum)
11. Sts. Margaret and Barbara
12. Donor Provost Peter Maurer

St. Sebastian Legend

13. Interrogation or Arrest of St.
 Sebastian
14. Attempted Martyrdom of St.
 Sebastian
15. Martyrdom of St. Sebastian
16. Rescue of the Body of St.
 Sebastian

Source: Brucher, Gunter. *Farbe und Licht in Albrecht Altdorfers Sebastiansaltar in St. Florian*.
 Graz: Akademisches Druck- u. Verlagsanstalt, 1978.

Scenes from the Lives of St. Lucy,
St. George, and the New Testament
Oratory of St. George
Padua
c.1377-84

ALTICHIERO

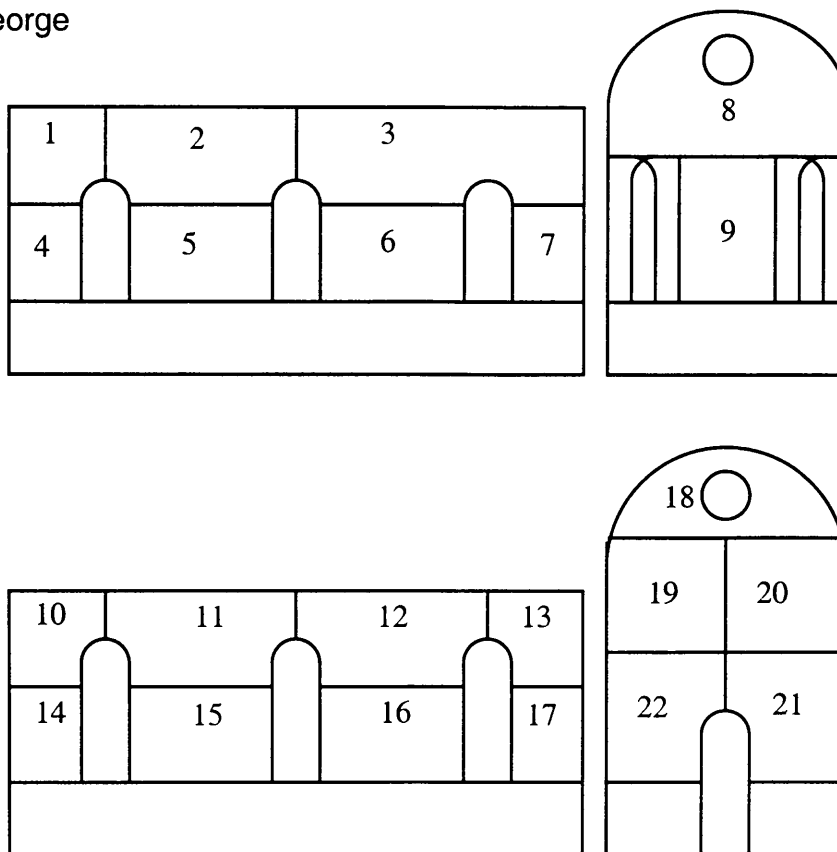

- | | |
|---|---|
| 1. St. George and the Dragon | 11. St. Catherine Debates with the Philosophers |
| 2. St. George Baptizes the King | 12. St. Catherine on the Wheel |
| 3. Knights of the Family of Lupi di Soragna Presented to the Virgin | 13. Beheading of St. Catherine |
| 4. St. George Drinks Poison | 14. St. Lucy before the Prefect |
| 5. St. George on the Wheel | 15. St. Lucy dragged off to Prison |
| 6. Fall of the Pagan Building | 16. Martyrdom of St. Lucy |
| 7. Beheading of St. George | 17. Funeral of St. Lucy |
| 8. Coronation of the Virgin | 18. Annunciation |
| 9. Crucifixion | 19. Nativity |
| 10. St. Catherine before the Emperor Maxentius | 20. Adoration of the Magi |
| | 21. Presentation in the Temple |
| | 22. Flight into Egypt |

Sources: Mellini, Gian Lorenzo. *Altichiero e Jacopo Avanzi*. Milan: Edizioni di Comunita, 1965.
Moleta, Vincent. *From St. Francis to Giotto: The Influence of St. Francis on Early Italian Art and Literature*. Chicago: Franciscan Herald Press, 1983.
Pettenella, Plinia. *Altichiero: e la pittura Veronese del Trecento*. Verona: Edizione di Vita Veronese, 1961.
White, John. *Art and Architecture in Italy, 1250-1400*. 1st ed. Harmondsworth, Middlesex: Penguin Books, 1966.

ANDREA DA FIRENZE
(Andrea Bonaiuti)
and Assistants

Spanish Chapel (Chapter Room)
Santa Maria Novella
Florence
c.1366-68

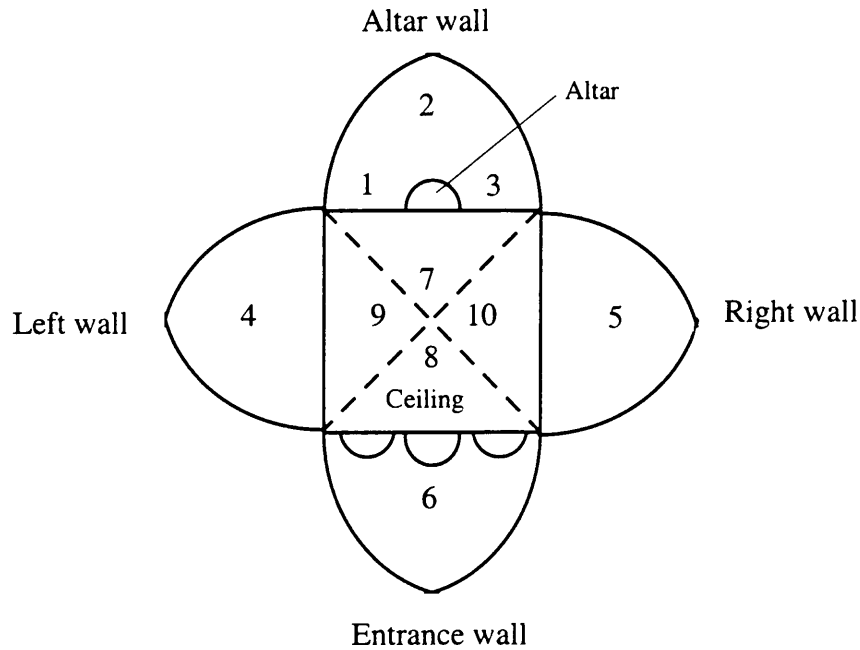

- | | |
|-------------------------------------|---------------------------------|
| 1. Road to Calvary | 6. Scenes of St. Peter Martyr |
| 2. Crucifixion | 7. Ascension |
| 3. Descent into Limbo | 8. Resurrection |
| 4. St. Thomas Aquinas Enthroned | 9. Pentecost |
| 5. Dominican Order; Church Militant | 10. Christ Walking on the Waves |

Sources: Borsook, Eve. *The Companion Guide to Florence*. 3rd ed. London: Collins, 1974.
Delaurier, Nancy. Sketched on site.

Annunciation
(executed for San Domenico, Cortona)
Museo Diocesano, Cortona
1433-34

FRA ANGELICO

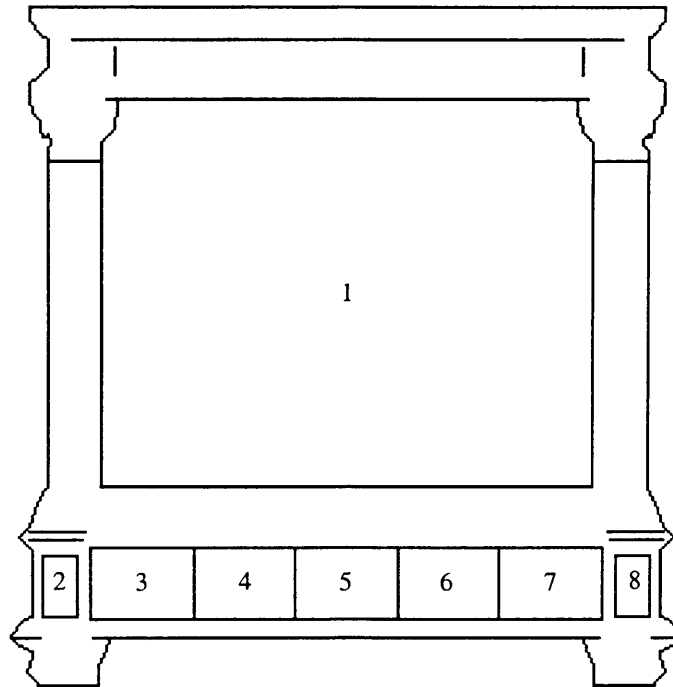

1. Annunciation
2. Birth of St. Dominic
3. Marriage of the Virgin
4. Visitation
5. Adoration of the Magi
6. Presentation in the Temple
7. Death of the Virgin
8. St. Dominic Receives the Habit of the Dominican Order

Sources: Baldini, Umberto. *L'opera completa dell' Angelico*. Milan: Rizzoli, 1970.
Pope-Hennessy, John W. *Fra Angelico*. 2nd ed. Ithaca, New York: Cornell University Press, 1974.

**FRA ANGELICO
and Workshop
(Benozzo Gozzoli,
Giovanni Antonio
della Checa, Pietro
d'Antonio da Poli, Carlo di
San Lazzaro da Narni)**

Lives of St. Stephen and
St. Lawrence
Chapel of Nicholas V
Vatican Palace, Vatican City
1448

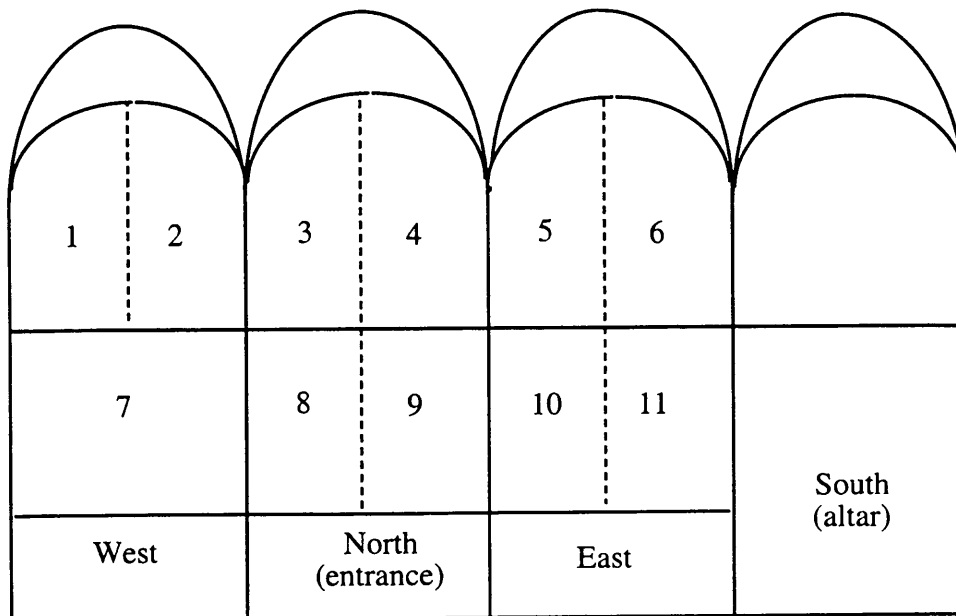

- | | |
|--|------------------------------------|
| 1. Ordination of St. Stephen by St. Peter | 9. St. Lawrence Distributing Alms |
| 2. St. Stephen Distributes Alms to the Poor | 10. St. Lawrence Before Valerianus |
| 3. St. Stephen Preaching | 11. Martyrdom of St. Lawrence |
| 4. St. Stephen's Sermon before the Sanhedrin | 12. St. Mark |
| 5. St. Stephen Led to his Martyrdom | 13. St. John |
| 6. Stoning of St. Stephen | 14. St. John |
| 7. Ordination of St. Lawrence by St. Sixtus | 15. St. Matthew |
| 8. St. Lawrence Receiving the Treasures of the Church from Pope Sixtus | |

Sources: Pope-Hennessy, John W. *Fra Angelico*. 2nd ed. Ithaca, N.Y.: Cornell University Press, 1974.

Roettgen, Steffi. *Italian Frescoes: Vol.1, The Early Renaissance, 1400-1470*. New York, London and Paris: Abbeville Press, 1995-96.

Linaiuoli Triptych
Museo di San Marco, Florence
1433

FRA ANGELICO

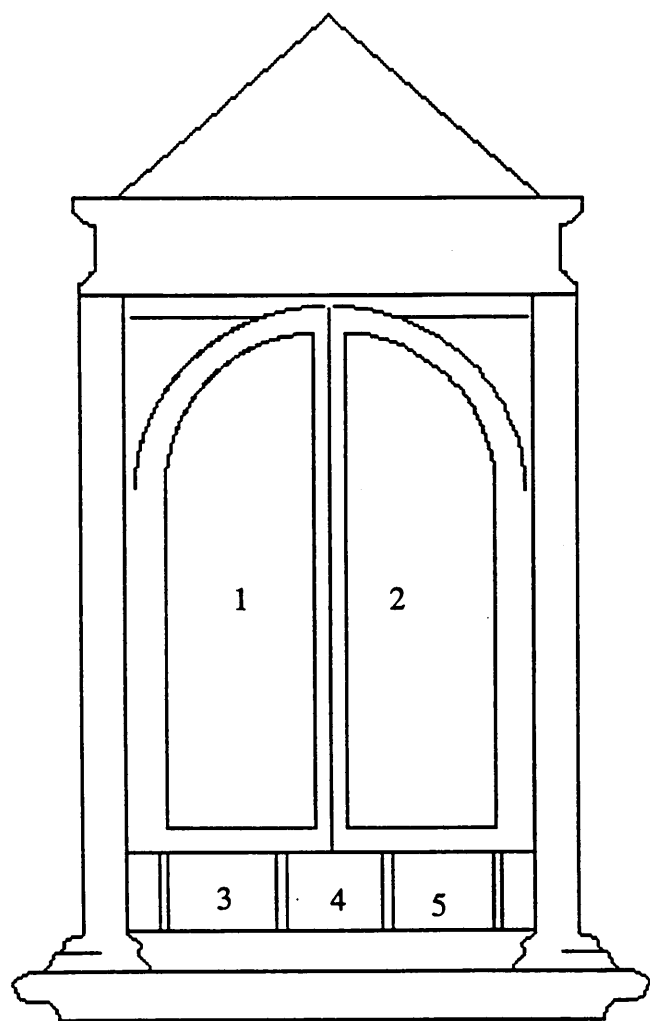

Closed

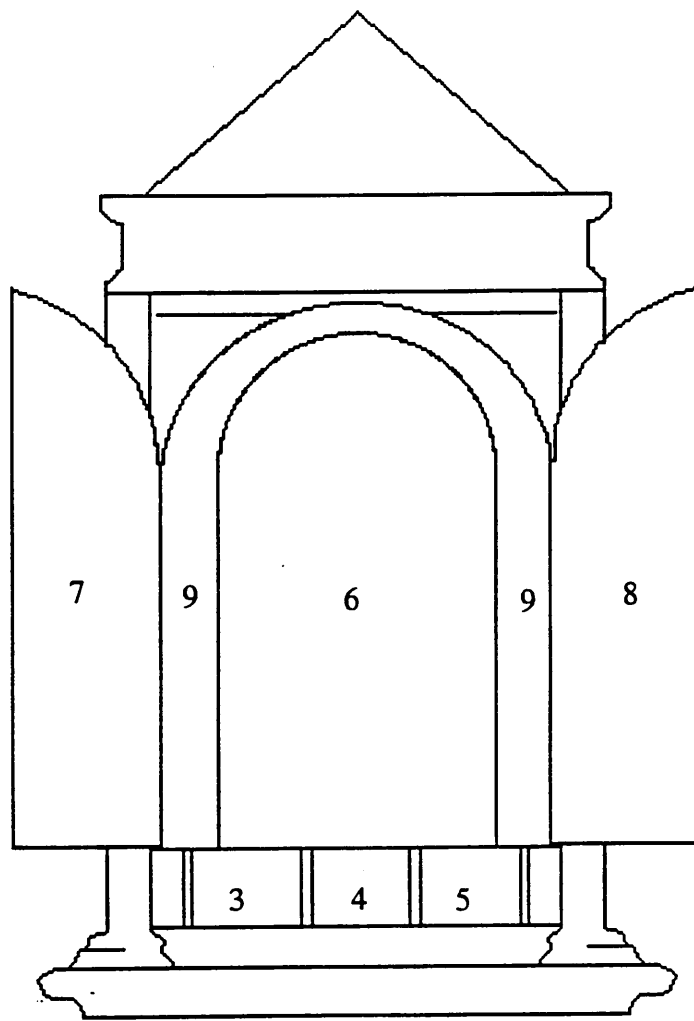

Open

1. St. Mark
2. St. Peter
3. St. Peter Preaching in the Presence of St. Mark
4. Adoration of the Magi

5. Martyrdom of St. Mark
6. Madonna and Child
7. St. John the Baptist
8. St. John the Evangelist
9. Border of Angels

Source: Baldini, Umberto. *L'opera completa dell' Angelico*. Milan: Rizzoli, 1970.

FRA ANGELICO

Madonna and Child with Saints
 (Pala di San Marco)
 Museo di San Marco, Florence
 (other locations listed below)
 1438-40

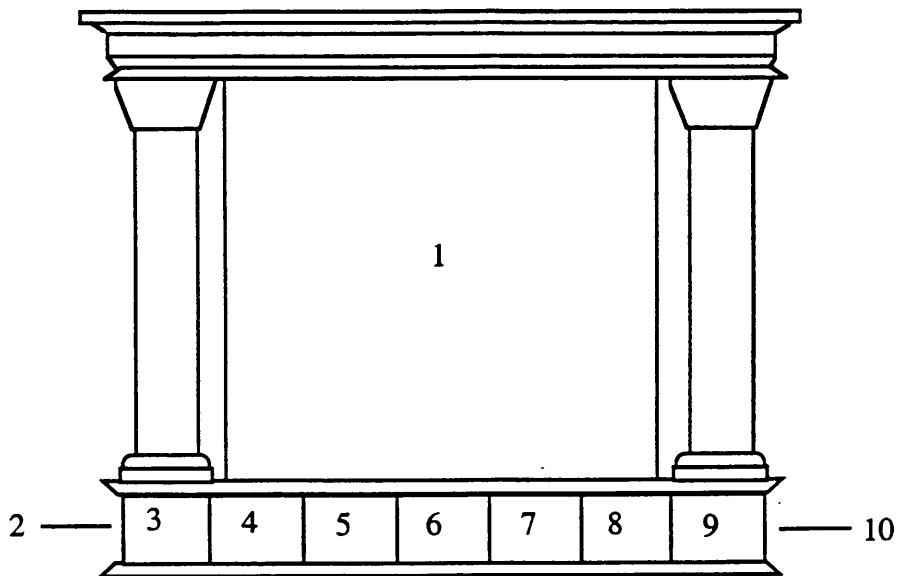

1. Madonna and Child Enthroned with Angels and Sts. Cosmas and Damian (center), Lawrence, John the Evangelist and Mark (left), and Dominic, Francis and Peter Martyr (right)
2. Healing of Palladia by Sts. Cosmas and Damian, and St. Damian Receiving a Gift from Palladia (Washington, DC, National Gallery of Art) (side of altarpiece)
3. Sts. Cosmas and Damian before Lycias (Munich, Alte Pinakothek)
4. Lycias Possessed by Devils (Munich, Alte Pinakothek)
5. Attempted Martyrdom of Sts. Cosmas and Damian by Fire (Dublin, National Gallery of Ireland)
6. Entombment (Munich, Alte Pinakothek)
7. Attempted Martyrdom of Sts. Cosmas and Damian by Crucifixion and Stoning (Munich, Alte Pinakothek)
8. Martyrdom of Sts. Cosmas and Damian by Decapitation (Paris, Louvre)
9. Burial of Sts. Cosmas and Damian
10. Healing of Deacon Justinian (side of altarpiece)

Source: Baldini, Umberto. *L'opera completa dell'Angelico*. Milan: Rizzoli, 1970.
 Pope-Hennessy, John W. *Fra Angelico*. 2nd ed. Ithaca, New York: Cornell University Press, 1974.

Perugia Altarpiece
 Galleria Nazionale dell' Umbria, Perugia
 and Vatican Museums, Vatican City
 1437

FRA ANGELICO

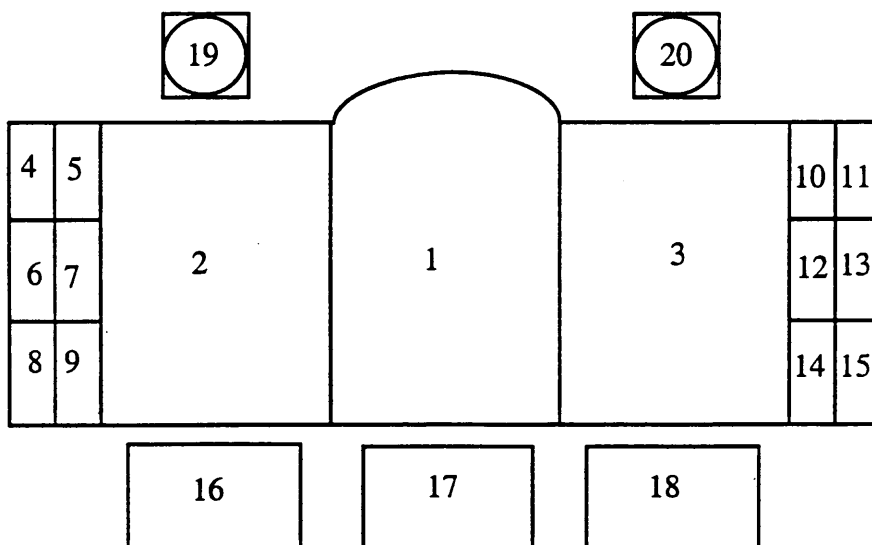

- | | |
|--|--|
| 1. Madonna and Child with Angels | 14. St. Thomas Aquinas |
| 2. Sts. Dominic and Nicholas of Bari | 15. St. Lawrence |
| 3. Sts. John the Baptist and Catherine of Alexandria | 16. Birth of St. Nicholas, His Vocation and Three Youths (Vatican City, Vatican Museums) |
| 4. St. Peter | 17. St. Nicholas Addresses an Imperial Emissary and St. Nicholas Calms the Storm (Vatican City, Vatican Museums) |
| 5. St. Paul | 18. St. Nicholas Saves Three Condemned Innocents and Death of St. Nicholas |
| 6. St. Louis of Toulouse | 19. Angel of the Annunciation |
| 7. St. Mary of Egypt | 20. Virgin of the Annunciation |
| 8. St. Benedict | |
| 9. St. Peter Martyr | |
| 10. St. John the Evangelist | |
| 11. St. Stephen | |
| 12. St. Catherine of Siena | |
| 13. St. Jerome | |

Source: Baldini, Umberto. *L'opera completa dell'Angelico*. Milan: Rizzoli, 1970.

**SAN FRANCISCO MASTER
(attributed to)**

Passion Cycle
Lower Church, San Francisco
Assisi
c.1250-1260's

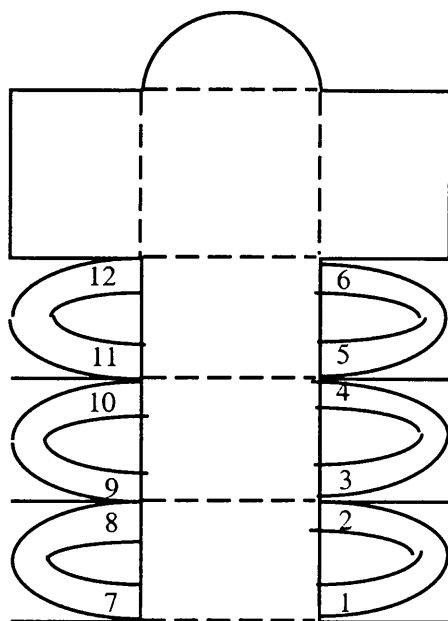

- | | |
|--|---------------------------------------|
| 1. Christ's Preparation for the Crucifixion | 7. St. Francis Repudiating His Father |
| 2. Crucifixion with Virgin and St. John the Evangelist | 8. Dream of Innocent III |
| 3. Descent from the Cross | 9. St. Francis Preaching to the Birds |
| 4. Lamentation | 10. Stigmatization |
| 5. Supper at Emmaus | 11. Death of St. Francis |
| 6. Decorative ornament | 12. Decorative Ornament |

Sources: Ruf, Gerhard. *Das Grab des hl. Franziskus: die Fresken der Unterkirche von Assisi*. Freiburg im Breisgau: Herder, 1981.

Schultze, Jurgen, "Zur Kunst des 'Franzishunsmeisters'." *Wallraf-Richartz Jahrbuch*, 25 (1963): 109-150.

Freiburger Altarpiece
Freiburg im Breisgau
Dom Museum
1512-16

BALDUNG GRIEN, HANS

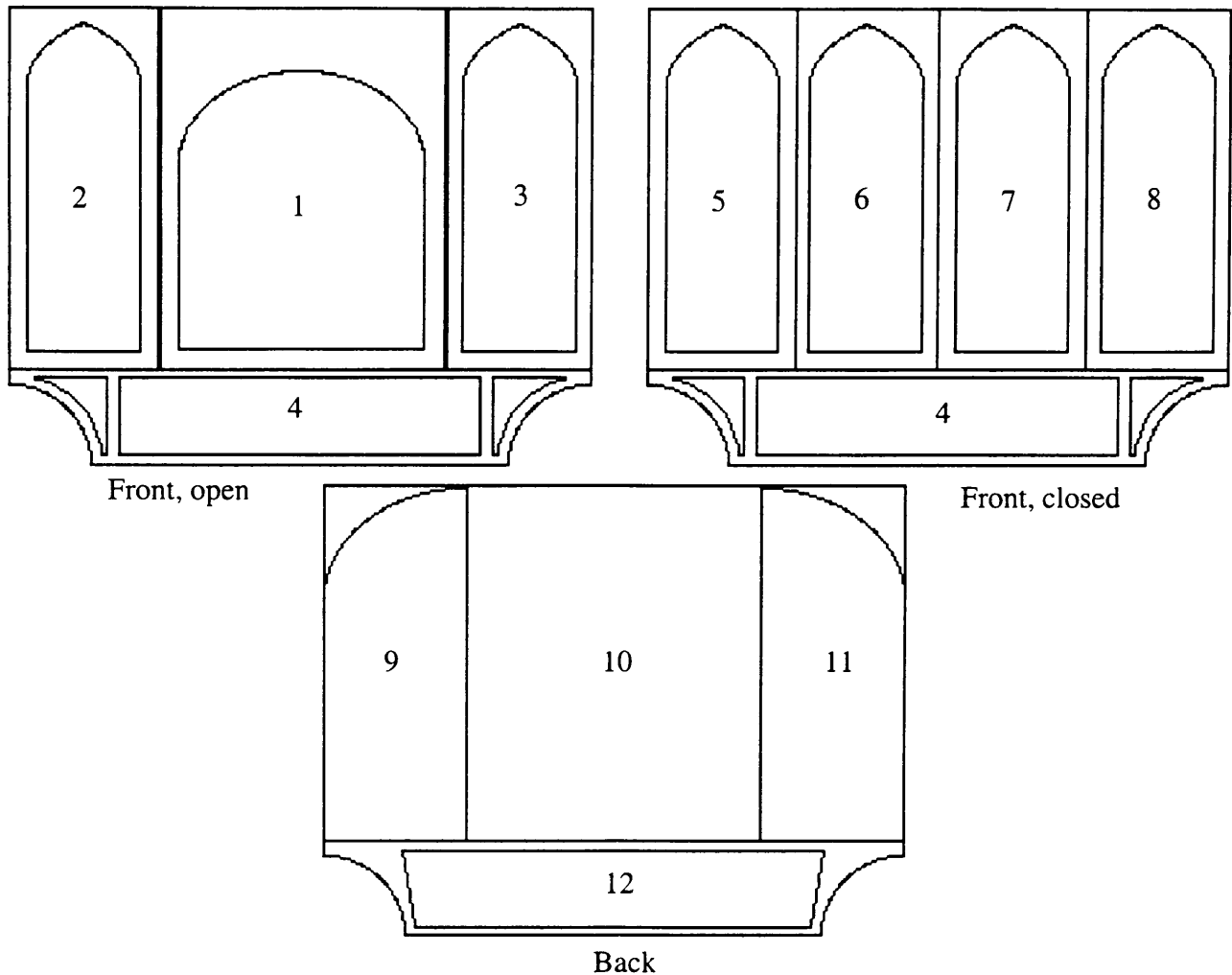

- | | |
|--|----------------------|
| 1. Coronation of the Virgin | 5. Annunciation |
| 2. St. Paul and Five Other Apostles | 6. Visitation |
| 3. St. Peter and Five Other Apostles | 7. Nativity |
| 4. Journey and Adoration of the Magi;
Virgin and Child; and Joseph at the Well
(front predella is in relief) | 8. Flight into Egypt |
| 9. Sts. Jerome and John the Baptist | |
| 10. Crucifixion | |
| 11. Sts. George and Lawrence | |
| 12. Virgin and Child with Donors | |

Source: Baumgarten, Fritz. *Der Freiburger Hochaltar: kunstgeschichtlich gewurdigt*. Reprint ed. Nendeln, Liechtenstein: Kraus, 1979.

BARNA DA SIENA

Life of Christ
 Right Aisle, Collegiata
 San Gimignano
 c.1340s

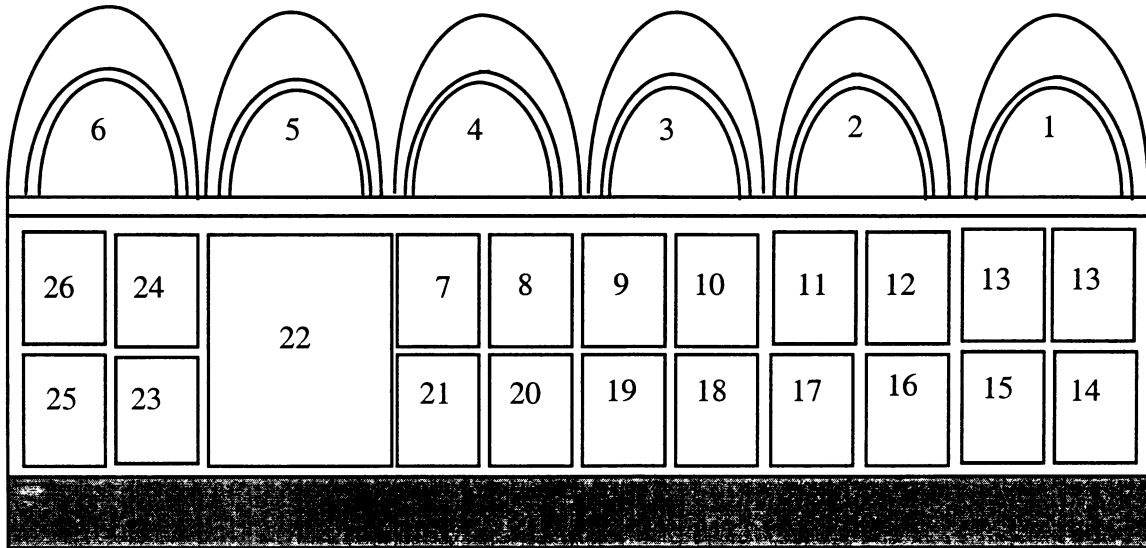

- | | | |
|-------------------------------|-------------------------------|-----------------------|
| 1. Annunciation | 10. Marriage at Cana | 20. Mocking of Christ |
| 2. Adoration of the Shepherds | 11. Transfiguration | 21. Road to Calvary |
| 3. Adoration of the Magi | 12. Raising of Lazarus | 22. Crucifixion |
| 4. Presentation in the Temple | 13. Entry into Jerusalem | 23. Entombment |
| 5. Massacre of the Innocents | (two sections) | 24. Resurrection |
| 6. Flight into Egypt | 14. Last Supper | 25. Decent into Limbo |
| 7. Christ among the Doctors | 15. Judas Receiving the Bribe | 26. Ascension |
| 8. Baptism | 16. Agony in the Garden | |
| 9. Calling of St. Peter | 17. Betrayal | |
| | 18. Christ before Pilate | |
| | 19. Flagellation | |

Sources: Borsook, Eve. *The Mural Painters of Tuscany: From Cimabue to Andrea del Sarto*. 2nd ed. Oxford: Clarendon Press, 1994.

Delogu Ventroni, Sebastiana. *Barna da Siena*. Pisa: Giardini, 1972.

White, John. *Art and Architecture in Italy, 1250-1400*. 2nd ed. Hamondsworth, Middlesex: Penguin Books, 1987.

Sala del Concistoro Vault
 Palazzo Pubblico, Siena
 1529-35

BECCAFUMI, DOMENICO

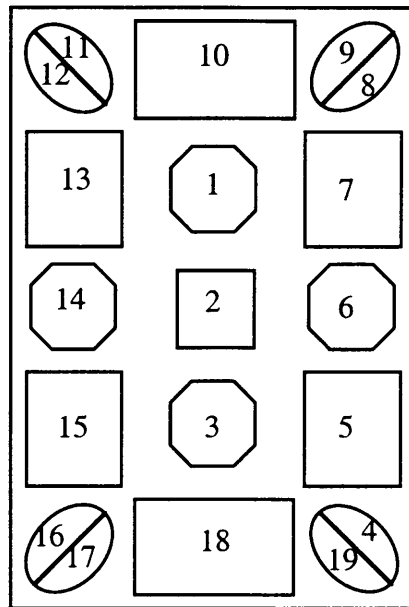

- | | |
|--|---|
| 1. Love of Country | 11. Genuzio Cipo (Love of Country) |
| 2. Justice | 12. Athenian Trasibulo (Love of Country) |
| 3. Good Will | 13. Publio Muzio Sends his Colleagues to the Stake (Justice) |
| 4. Consul Lucio Bruto (Justice) | 14. Decapitation of Spurio Cassio (Justice) |
| 5. Murder of Spurio Melio (Justice) | 15. Posthumus Tuberto Kills his own Son (Justice) |
| 6. Marco Manlio Falls from the Campodoglio (Justice) | 16. Stasippo di Tegea (Good Will) |
| 7. Sacrifice of Zaleuco di Locri (Justice) | 17. Fabio Massimo (Good Will) |
| 8. Judge Caronda di Thurii (Justice) | 18. Reconciliation of Emilio Lepido and Fulvio Flacco (Good Will) |
| 9. Magistrate Elio (Love of Country) | 19. Damone Pitagorico (Good Will) |
| 10. Sacrifice of Codro, King of Athens (Love of Country) | |

Source: *Domenico Beccafumi e il suo tempo*. Milan: Electa, 1990.

BELLINI, GIOVANNI

Pesaro Altarpiece
(Coronation of the Virgin)
(reconstruction)
Museo Civico, Pesaro and
Vatican Museums, Vatican City
c.1470

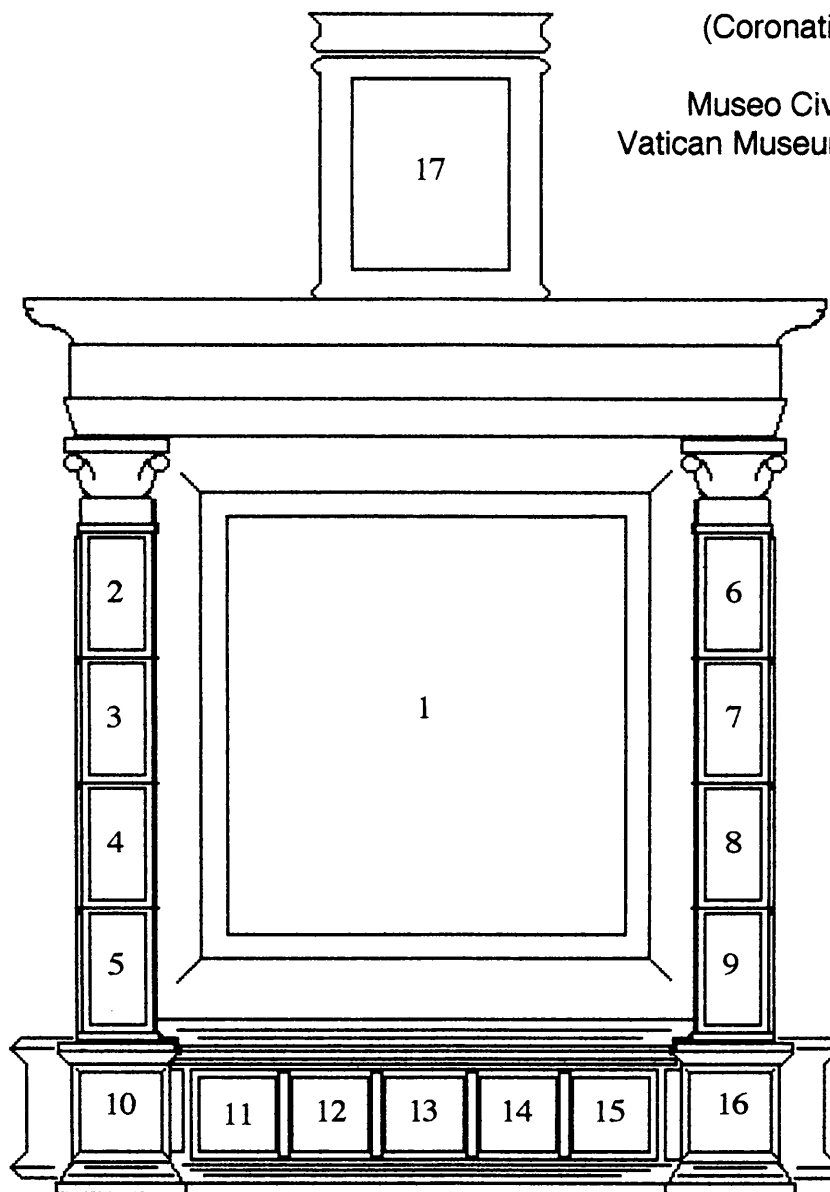

- | | |
|-------------------------------|--|
| 1. Coronation of the Virgin | 11. Conversion of St. Paul |
| 2. St. Catherine | 12. Crucifixion of St. Peter |
| 3. St. Lawrence | 13. Nativity |
| 4. St. Anthony of Padua | 14. St. Jerome in the Desert |
| 5. St. John the Baptist | 15. Stigmatization |
| 6. Blessed Michelina | 16. St. Terentius, Patron Saint of
Pesaro |
| 7. St. Bernardino of Siena | 17. Lamentation (Vatican City,
Vatican Museums) |
| 8. St. Louis of Toulouse | |
| 9. St. Andrew | |
| 10. St. George and the Dragon | |

Source: Goffen, Rona. *Giovanni Bellini*. New Haven and London: Yale University Press, 1989.

Polyptych of St. Vincent Ferrer
Church of Sts. Giovanni e Paolo, Venice
late 1460s to early 1470s

BELLINI, GIOVANNI

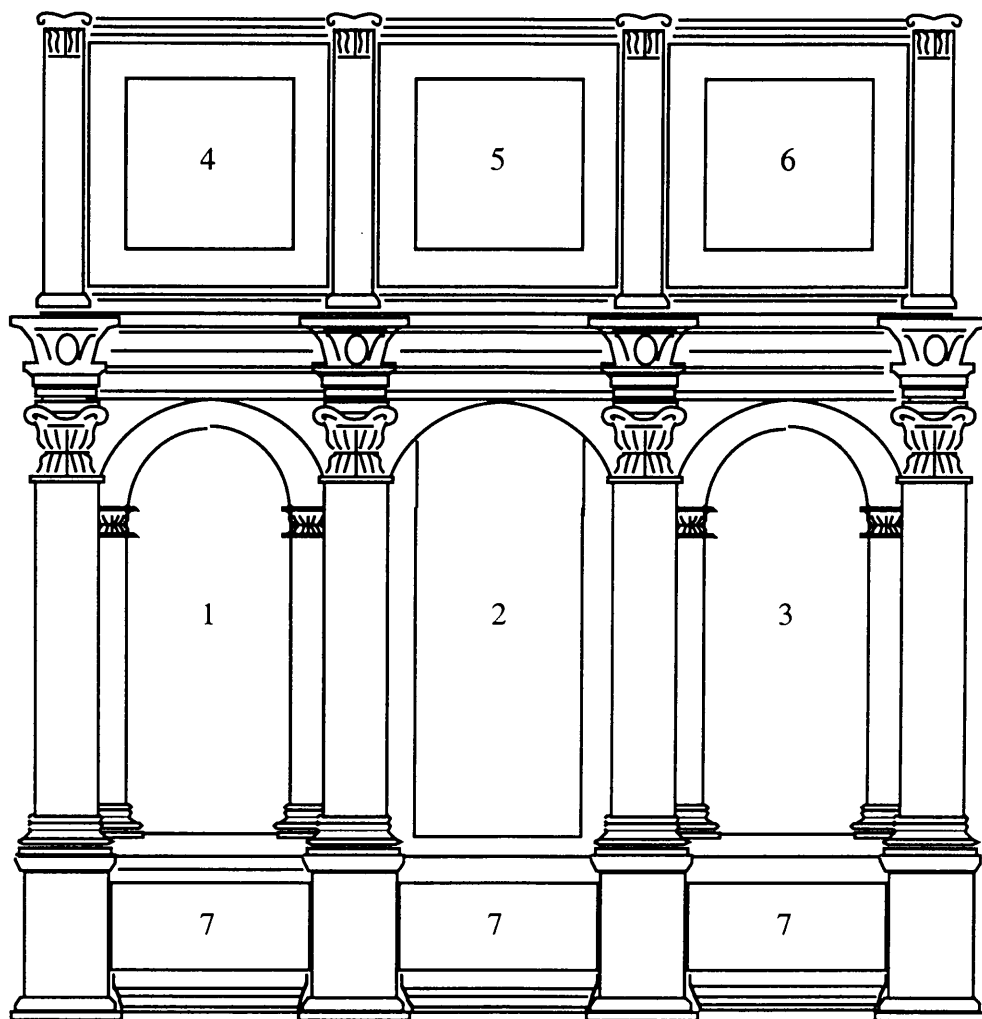

- | | |
|-----------------------|-------------------------------|
| 1. St. Christopher | 4. Angel of the Annunciation |
| 2. St. Vincent Ferrer | 5. Pieta |
| 3. St. Sebastian | 6. Virgin of the Annunciation |

7. Life of St. Vincent
(These scenes are by an artist other than
Bellini.)

Source: Goffen, Rona. *Giovanni Bellini*. New Haven and London: Yale University Press, 1989.

BONANUS OF PISA

Porta di San Ranieri, South Transept
Cathedral, Pisa
c.1180

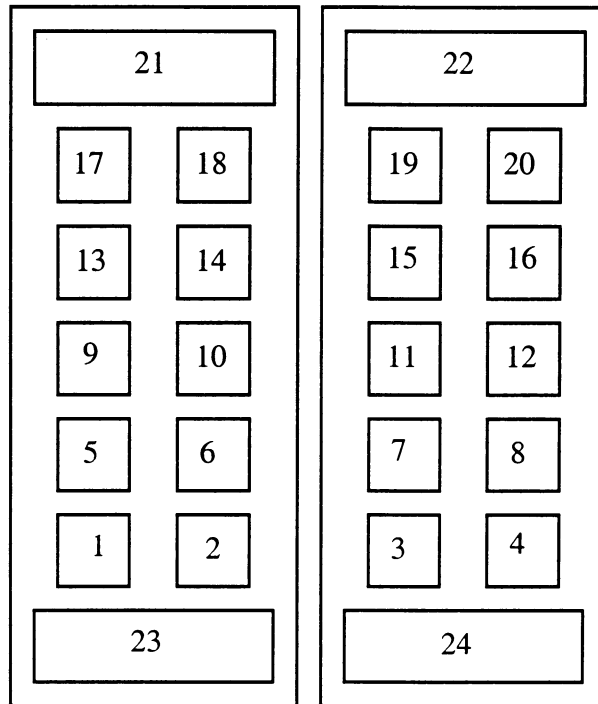

- | | |
|---------------------------------|--|
| 1. Annunciation | 13. Christ Washing the Disciples' Feet |
| 2. Visitation | 14. Last Supper |
| 3. Nativity | 15. Betrayal |
| 4. Adoration of the Magi | 16. Crucifixion |
| 5. Presentation in the Temple | 17. Descent into Limbo |
| 6. Flight into Egypt | 18. Three Maries at the Tomb |
| 7. Christ before Herod | 19. Pentecost |
| 8. Baptism | 20. Death of the Virgin |
| 9. Temptation in the Wilderness | 21. Christ Enthroned |
| 10. Transfiguration | 22. Virgin Enthroned |
| 11. Raising of Lazarus | 23. Six Prophets |
| 12. Entry into Jerusalem | 24. Six Prophets |

Source: Boeckler, Albert. *Die Bronzetauren des Bonanus von Pisa und des Barisanus von Trani*. Berlin: Deutscher Verein für Kunstwissenschaft, 1953.

Adoration of the Magi Triptych
Prado Museum, Madrid
c.1510

BOSCH, HIERONYMUS

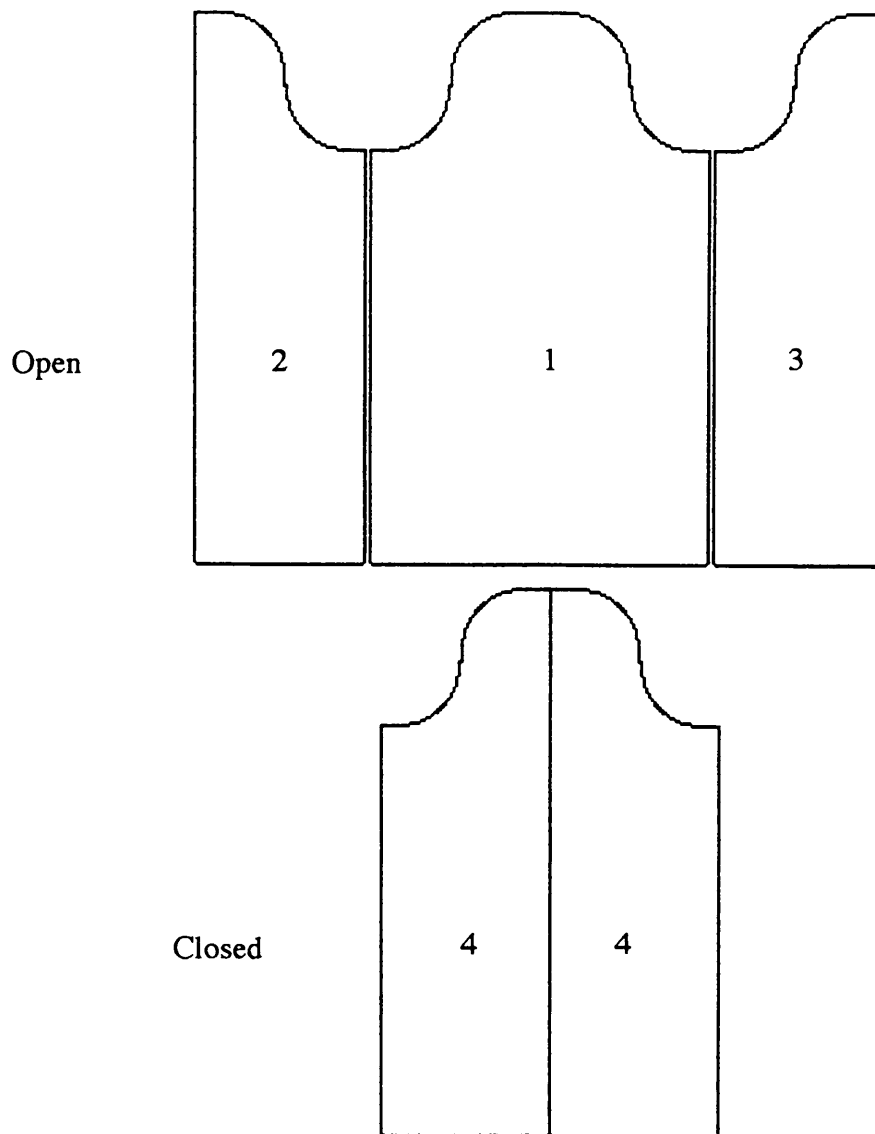

1. Adoration of the Magi
2. St. Peter with Donor
3. St. Ines with Donor
4. Mass of St. Gregory

Source: Brans, Jan V.L. *Hieronymus Bosch (El Bosco) en el Prado y en el Escorial*. Barcelona: Ediciones Omega, 1948.

BOUTS, DIRK

Altarpiece of the Holy Sacrament
Church of St. Peter
Leuven, Belgium
1464-68

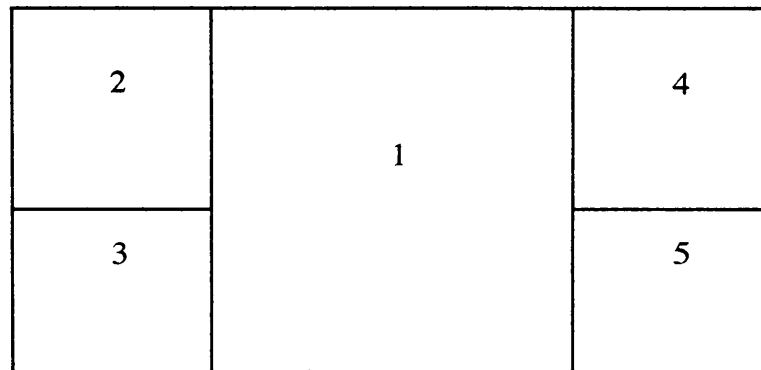

1. Last Supper
2. Meeting of Abraham and Melchizedek
3. Gathering of Manna
4. Elijah in the Desert
5. Passover

Sources: Friedlander, Max J. *Early Netherlandish Painting*. Vol. 3, *Dieric Bouts and Joos van Gent*. Leiden: A.W. Sijthoff, 1968.

Lassaigne, Jacques. *Flemish Painting*. Vol. 2. *From Bosch to Rubens*. New York: Skira, 1958.

Galleria Ceiling
 Palazzo Farnese, Rome
 c.1600

CARRACCI, ANNIBALE

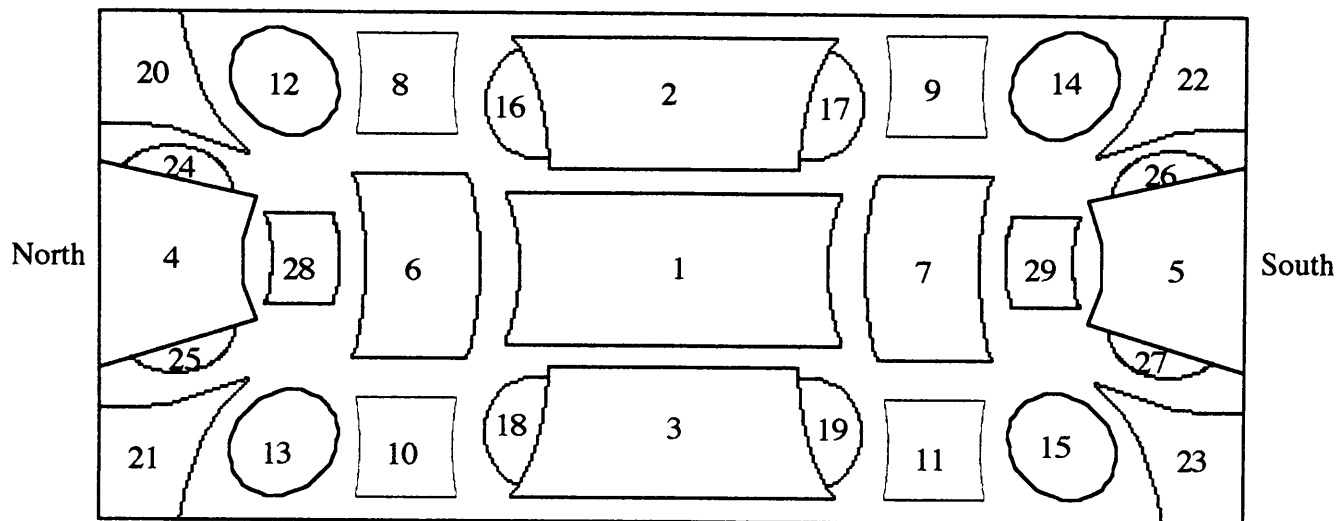

- | | |
|-----------------------------------|--------------------------------------|
| 1. Triumph of Bacchus and Ariadne | 16. Pan and Syrinx |
| 2. Aurora and Cephalus | 17. Salmacis and Hermaphroditus |
| 3. Glaucus and Scylla | 18. Boreas and Oreithyia |
| 4. Polyphemus and Acis | 19. Orpheus and Eurydice |
| 5. Polyphemus and Galatea | 20. Union of Sacred and Profane Love |
| 6. Diana and Pan | 21. Struggle for the Palm |
| 7. Mercury and Paris | 22. Struggle for the Torch |
| 8. Venus and Anchises | 23. Struggle under the Wreath |
| 9. Hercules and Iole | 24. Judgement of Paris |
| 10. Jupiter and Juno | 25. Paris and Apollo |
| 11. Diana and Endymion | 26. Abduction |
| 12. Cupid and Pan | 27. Jason and the Golden Fleece |
| 13. Apollo and Marsyas | 28. Ganymede and the Eagle |
| 14. Hero and Leander | 29. Apollo and Hyacinthus |
| 15. Rape of Europa | |

Sources: Martin, John Rupert. *The Farnese Gallery*. Princeton, New Jersey: Princeton University Press, 1965.

Posner, Donald. *Annibale Carracci: A Study in the Reform of Italian Painting around 1590*. 2 vols. London: Phaidon, 1971.

CASTAGNO, ANDREA DEL

Christ's Passion
(former Refectory)
Sant' Apollonia, Florence
c.1447-50

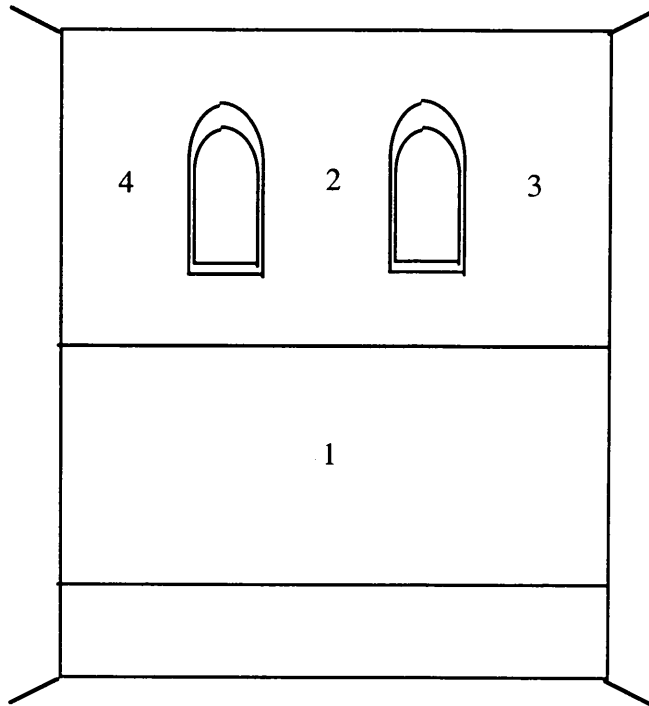

1. Last Supper
2. Crucifixion
3. Entombment
4. Resurrection

Source: Borsook, Eve. *The Mural Painters of Tuscany: From Cimabue to Andrea del Sarto*. 2nd ed.
Oxford: Clarendon Press, 1980.

Upper Church
San Francesco, Assisi
c.1280

CIMABUE

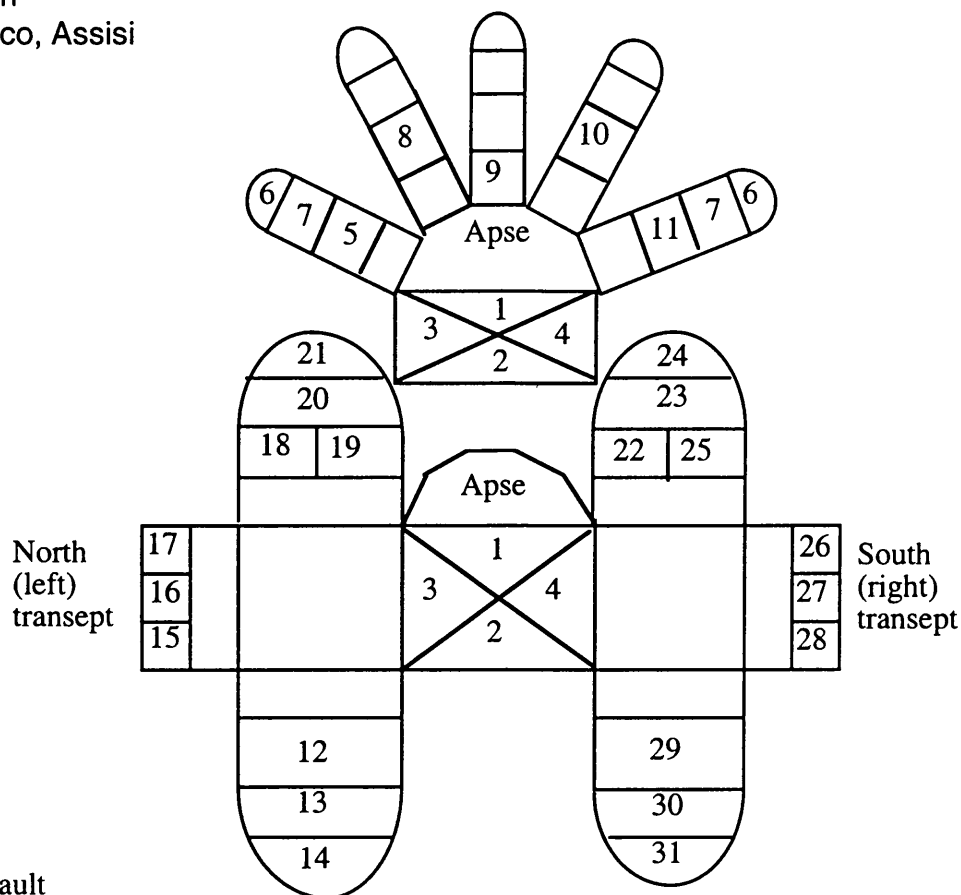

Vault

1. St. Luke
2. St. Matthew
3. St. Mark
4. St. John

Apse

5. Gathering of the Apostles
6. Early Life of the Virgin
7. Angels and Saints (in arcading)
8. Death of the Virgin
9. Two Roundels with Papal half-lengths
10. Assumption
11. Virgin in Majesty

North transept

12. Crucifixion
13. Archangels (in arcading)
14. Lost design
15. Adoration of the Lamb

16. Four Angels
17. Christ the Judge
18. Fall of Babylon
19. St. John the Evangelist on Patmos
20. Archangels (in arcading)
21. St. Michael and the Dragon

South transept

22. St. Peter Healing the Lame
23. Apostles (in arcading)
24. Christ in Glory
25. St. Peter Healing the Possessed
26. Fall of Simon Magus*
27. Crucifixion of St. Peter*
28. Martyrdom of St. Paul*
29. Crucifixion*
30. Apostles (in arcading)
31. Transfiguration

*Workshop (White, p.181)

Sources: Moleta, Vincent. *From St. Francis to Giotto: The Influence of St. Francis on Early Italian Art and Literature*. Chicago: Franciscan Herald Press, 1983.

White, John. *Art and Architecture in Italy, 1250-1400*. 1st ed. Harmondsworth, Middlesex: Penguin Books, 1966.

CRIVELLI, CARLO

Polyptych of Ascoli Piceno
Chapel of the Sacraments
Cathedral of St. Emidio
Ascoli Piceno
1473

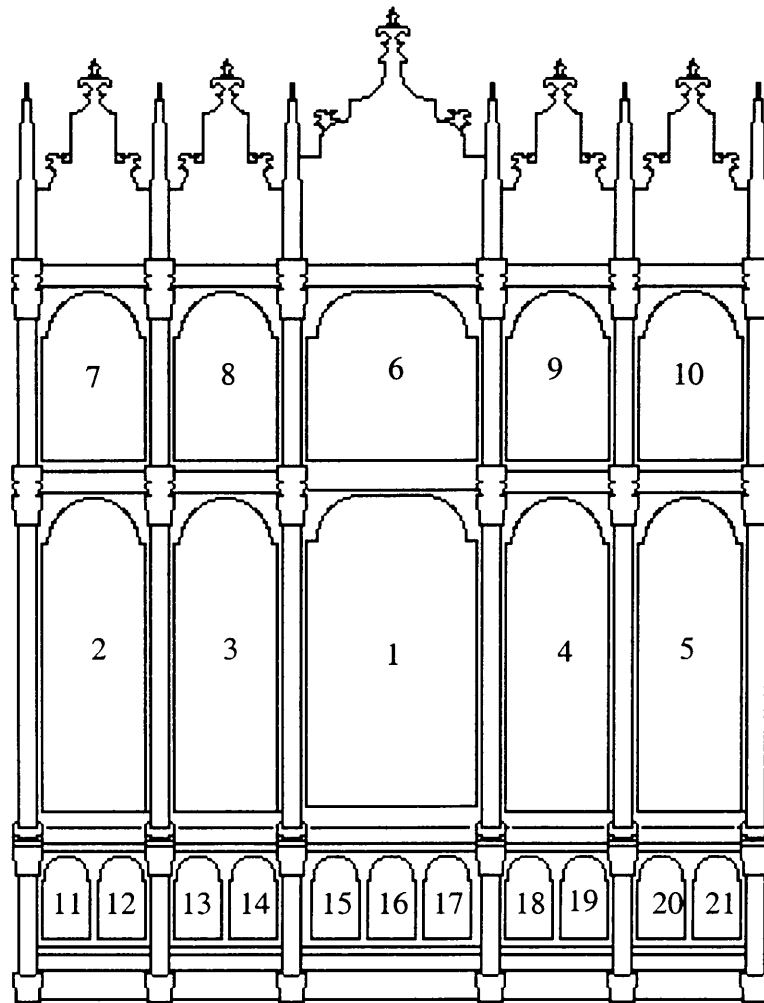

1. Madonna and Child Enthroned
2. St. Peter
3. St. John the Baptist
4. St. Emidio
5. St. Paul
6. Lamentation
7. St. Catherine of Alexandria
8. St. Jerome
9. St. George
10. St. Ursula

Predella

11. Apostle
12. St. Matthew
13. St. Andrew
14. St. John Major
15. St. Peter
16. Christ Blessing
17. St. Paul
18. St. Bartholomew
19. St. John Minor
20. Apostle (?)
21. St. John (?)

Source: Zampetti, Pietro. *Carlo Crivelli*. Florence: Nardini, 1986.

Polyptych in Seven Leaves
 (Painted for the high altar of San Pancrazio)
 Uffizi, Florence and
 Hampton Court Palace, Hampton Court
 14c.

DADDI, BERNARDO

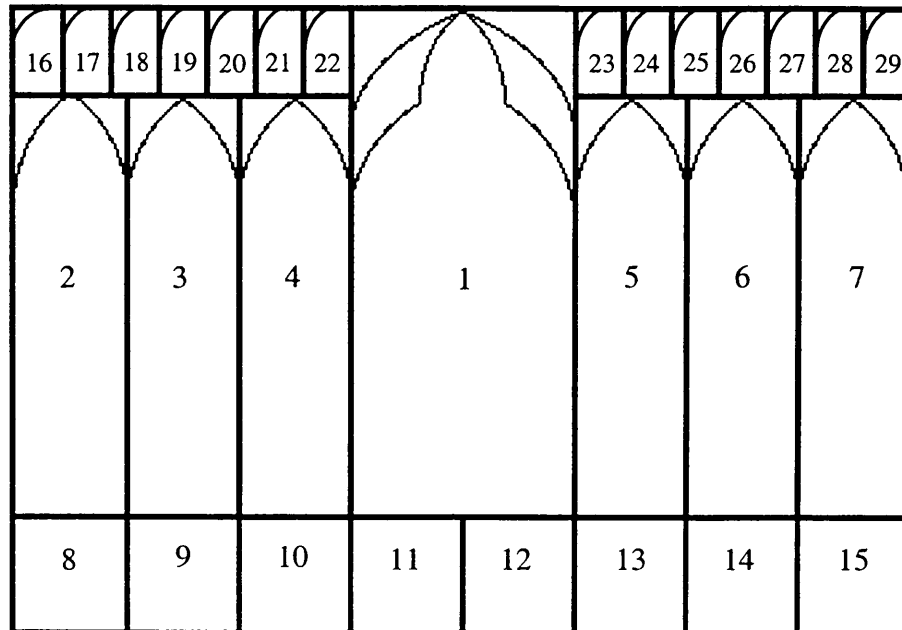

1. Madonna and Child with Angels
2. St. Pancras
3. St. Nereus
4. St. John the Evangelist
5. St. John the Baptist
6. St. Achilles
7. St. Reparata
8. Joachim Cast Out of the Temple
9. Annunciation to Joachim
10. Meeting at the Golden Gate
11. Birth of the Virgin
12. Presentation of the Virgin
13. Marriage of the Virgin (Hampton Court,
Hampton Court Palace)
14. Annunciation
15. Nativity
- 16-29. Seven Half-length Figures of Saints and
Apostles on Either Side of the Central Panel

Source: Offner, Richard. *A Critical and Historical Corpus of Florentine Paintings. Section 3, Fourteenth Century. Vol. 3, The Works of Bernardo Daddi.* New York: New York University Press, 1930.

DADDI, BERNARDO

Fragmentary Predella with Seven Scenes from
the Legend of the Holy Girdle (Possibly from
an altarpiece which in 1390 was at the altar of
the Capella del Cingolo in Prato.)
Museo Communale, Prato

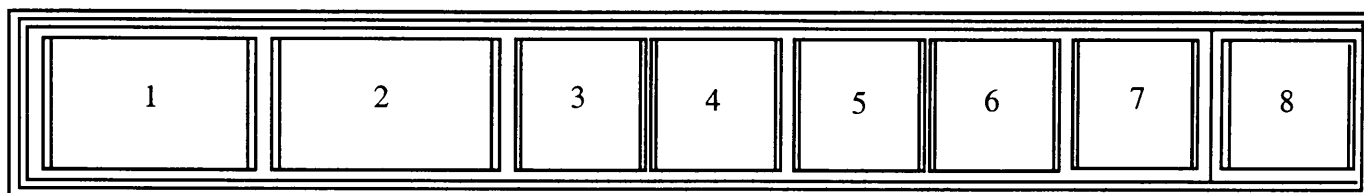

1. The Apostles Standing around the Empty Tomb of the Virgin and St. Thomas Holding the Girdle
2. St. Thomas Gives the Girdle into the Custody of an Aged Priest
3. Michele Dagomari in Palestine Receiving His Bride from the Hands of Her Mother
4. The Mother Gives the Girdle, in a Bag, to Michele
5. Michele and His Wife Return in a Small Boat from the Holy Land to Italy
6. Michele Sleeps with His Head on the Relic and Two Angels Lift Him From It and Place Him on the Floor
7. Michele, on His Deathbed, Leaves the Girdle to Ubaldo, the Provost of the Parish
8. Missing Scene

Source: Offner, Richard. *A Critical and Historical Corpus of Florentine Painting. Section 3, Fourteenth Century. Vol. 3, The Works of Bernardo Daddi.* New York: New York University Press, 1930.

Baptism Altarpiece (Altarpiece of
Jean des Trompes)
Musee Communal, Bruges
1500-10

DAVID, GERARD

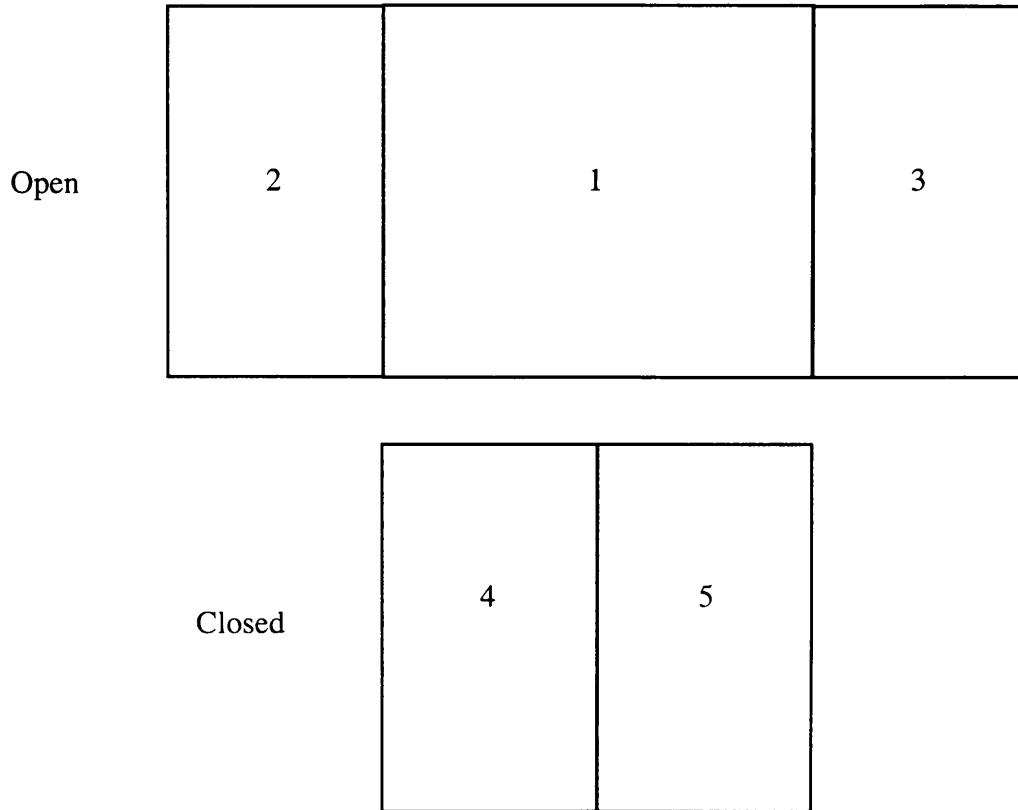

1. Baptism
2. Donor Jean des Trompes and His Son Philip, Presented by St. John the Baptist
3. Elisabeth van der Meersch and Her Daughters, Adewije, Anne, Jeanne, and Agnes, presented by St. Elizabeth of Hungary
4. Virgin and Child
5. Madeleine Cordier and Her Daughter Cornelia Presented by St. Mary Magdalen

Source: Blum, Shirley Neilsen. *Early Netherlandish Triptychs: A Study in Patronage*. Berkeley and Los Angeles: University of California Press, 1969.

**DONATELLO AND
MICHELOZZO DI
BARTOLOMEO**

Bronze Doors and Stucco Reliefs
Old Sacristy, San Lorenzo
Florence
1433-43 and 1475

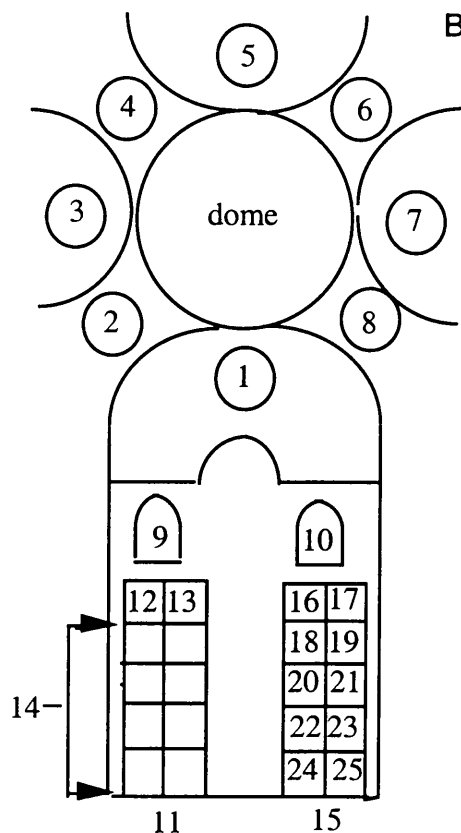

Stucco roundels

1. St. John the Evangelist
2. St. John on Patmos
3. St. Luke
4. Raising of Drusiana
5. St. Mark
6. Ascension of St. John the Evangelist
7. St. Matthew
8. Attempted Martyrdom of St. John the Evangelist Immersed in a Cauldron of Boiling Oil

Stucco reliefs above doors

9. Sts. Stephen and Lawrence
10. Sts. Cosmas and Damian

Bronze door reliefs

11. Door of Martyrs (left)
12. Sts. Stephen and Lawrence

13. Sts. Cosmas and Damian
14. Sixteen Disputing Martyrs
15. Door of Apostles (right)
(Seven reliefs completed by Michelozzo in 1475)
16. Sts. John the Baptist and John the Evangelist
17. Sts. Peter and Paul
18. Sts. Andrew and James the Greater
19. Sts. Phillip and Bartholomew
20. Sts. James the Less and Thomas (?)
21. Sts. Simon and Thaddeus
22. Sts. Mattias and Matthew
23. Sts. Luke and Mark
24. Sts. Augustine and Jerome
25. Sts. Gregory and Ambrose

Sources: Bennett, Bonnie A. and David G. Wilkens. *Donatello*. Oxford: Phaidon Press, 1984.

Janson, H.W. *The Sculpture of Donatello*. 2 vols. Princeton, N.J.: Princeton University Press, 1963.

Millon, Henry A. and Vittorio Magnano Lampugnani, eds. *The Renaissance from Brunelleschi to Michelangelo: The Representation of Architecture*. New York: Rizzoli, 1997.

Pope-Hennessy, John W. *Donatello: Sculptor*. New York: Abbeyville Press, 1993.

Turner, Jane, ed. *Dictionary of Art*. 34 vols. New York: Grove Dictionaries, 1996.

Bronze Pulpits
 San Lorenzo
 Florence
 1460-70

DONATELLO

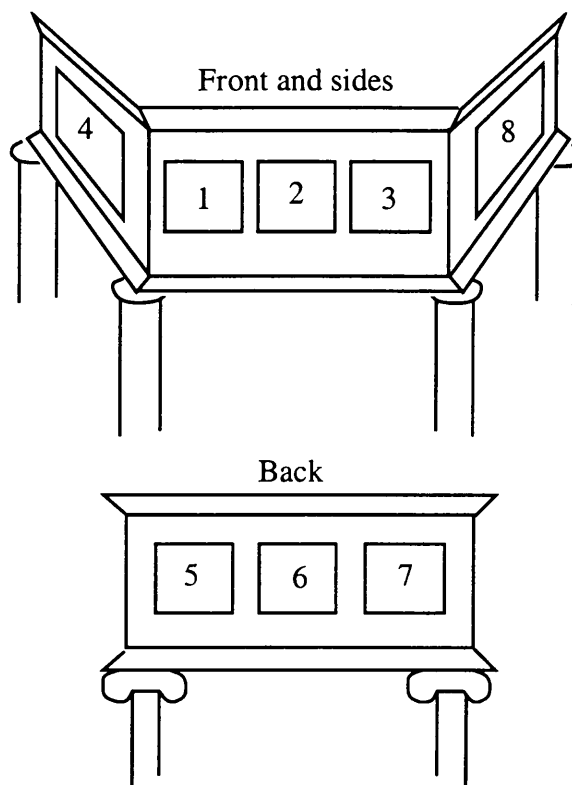
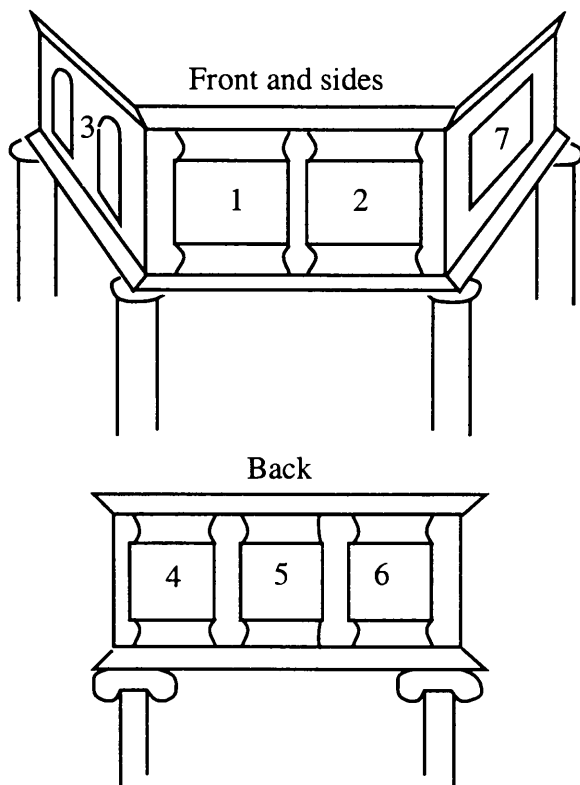

North pulpit

1. Crucifixion
2. Lamentation
3. Christ before Pilate and Christ before Caiaphas
4. Flagellation *
5. St. John the Baptist*
6. Agony in the Garden
7. Entombment

South pulpit

1. Descent into Limbo
 2. Resurrection
 3. Ascension
 4. Three Maries at the Tomb
 5. Martyrdom of St. Lawrence
 6. St. Luke*
 7. Crowning with Thorns*
 8. Pentecost
- * Supplemental wooden reliefs.

Sources: Bennett, Bonnie A. and David G. Wilkins. *Donatello*. Oxford: Phaidon Press, 1984.
 Collareta, Marco, ed. *Donatello in Toscana: itinerario*. Florence: S.P.E.S., 1985.
 Goldscheider, Ludwig. *Donatello*. Phaidon ed. New York: Oxford University Press, 1941.
 Janson, H.W. *The Sculpture of Donatello*. 2 vols. Princeton, N.J.: Princeton University Press, 1963.
 Poeschke, Joachim. *Donatello and his World: Sculpture of the Italian Renaissance*. New York: Harry N. Abrams, 1993.
 Santi, Bruno. *San Lorenzo: Guide to the Laurentian Complex*. Florence: Scala, 1992.

FLORENCE
(artists listed below)

Guild Niches and Exterior Sculpture
Orsanmichele
1339-1602

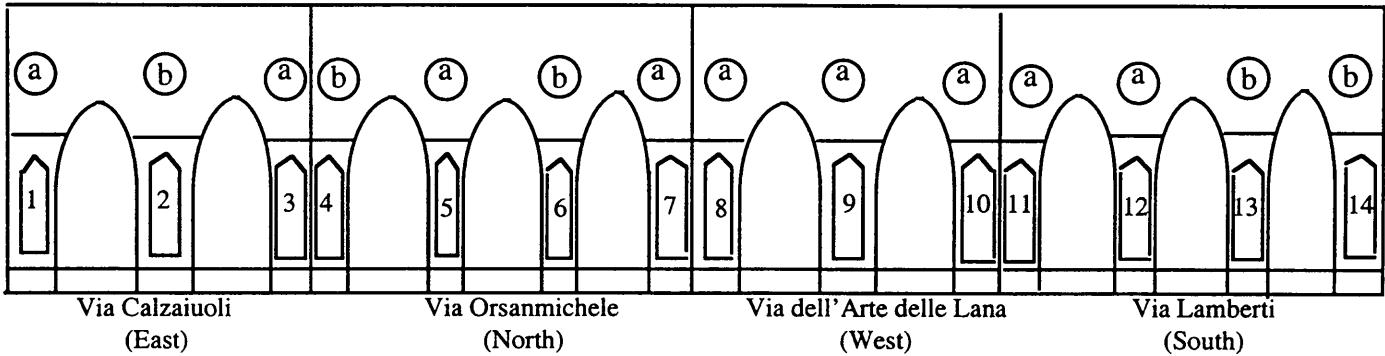

1. Niche: Albizzo di Piero and others based on Ghiberti's design (b&z), Wool Merchants Guild (s); Sculpture: removed
2. Niche: Michelozzo and Donatello, 1423-25 (b), Merchant's Court; Sculpture: removed
3. Niche: Michele Lamberti, 1403-06 (b), Judges and Notaries Guild; Sculpture: Jean Boulogne (known as Giambologna), St. Luke 1601 (b), 1602 (z)
4. Niche: 1412? (z), Butchers Guild; Sculpture: removed
5. Niche: Nanni di Banco (b), Tanners Guild (b); Sculpture removed
6. Niche: Mason and Carpenters Guild, Bas relief, Nanni di Banco, Four Crowned Saints at Their Work, c.1413 (b); Sculpture: Nanni di Banco, Four Crowned Saints, c.1411-13 (s), c.1413 (b), 1416-17 (z)
7. Niche: probably designed by Donatello (z), Armourers Guild; Bas relief, Donatello, St. George Killing the Dragon, 1417 (s), c.1417 (b), 1418 (z); Sculpture: Donatello, St. George, begun c.1415 (s), 1417 (b), 1418 (z), bronze copy, 1892 (z)
8. Niche: Bankers Guild; Sculpture: Lorenzo Ghiberti, St. Matthew, 1419-21 (s), 1419-23 (b&z)
9. Niche: 1339-40 (b), c.1341 (z), Wool Guild; Sculpture: Lorenzo Ghiberti, St. Stephen, 1428 (s), 1425-28 (b), 1429 (z)
10. Niche: Nanni di Banco, c.1419-21 (z); Bas relief, Nanni di Banco, Miracle of the Severed Hoof (z), Farriers Guild; Sculpture: removed
11. Niche: Perferro di Giovanni and Albizzo di Piero, 1411 (b), c.1413 (z), Linen Weavers Guild (s); Sculpture: Donatello, St. Mark (copy), 1411-13 (b), after 1412 (z)
12. Niche: c.1420 (z), Furriers Guild; Sculpture: removed
13. Niche: attributed to Simone Talenti (b); Tondo, Luca della Robbia, Virgin with Child, 1455-65 (b), 1465 (z), Doctors and Pharmacists Guild; Sculpture: Lorenzo di Giovanni d'Ambrogio? (s), Niccolo di Pietro Lamberti (b), Niccolo? (z), Madonna della Rosa, 1399, before 1399 (z)
14. Niche: 1415-16 (b), c.1340 (z); Tondo, Andrea della Robbia, Emblem of the Silk Guild, 1450-60 (b), 1465 (z), Silk Guild; Sculpture: Jacopo di Piero Guidi? (s), Baccio da Montelupo (z), St. John the Evangelist, 1515 (b&z)
 - a. Guild insignia, frescoed fragment (z)
 - b. Guild insignia, enamelled terracotta (z)

b=Borsook s=Seymour z=Zervas. If no letter designation is noted, authors concur on the information.

Sources: Borsook, Eve. *The Companion Guide to Florence*, 3rd ed. London: Collins, 1974.
Seymour, Charles. *Sculpture in Italy: 1400-1500*. Harmondsworth: Penguin Books, 1966.
Zervas, Diane Finiello, ed. *Orsanmichele a Firenze*. 2 vols. Modena: F.C. Panini, 1996.

Maesta (front)
 Museo dell'Opera del Duomo, Siena
 (National Gallery, London)
 (National Gallery of Art, Washington,
 D.C.)
 1309-11

DUCCIO DI BUONINSEGNA

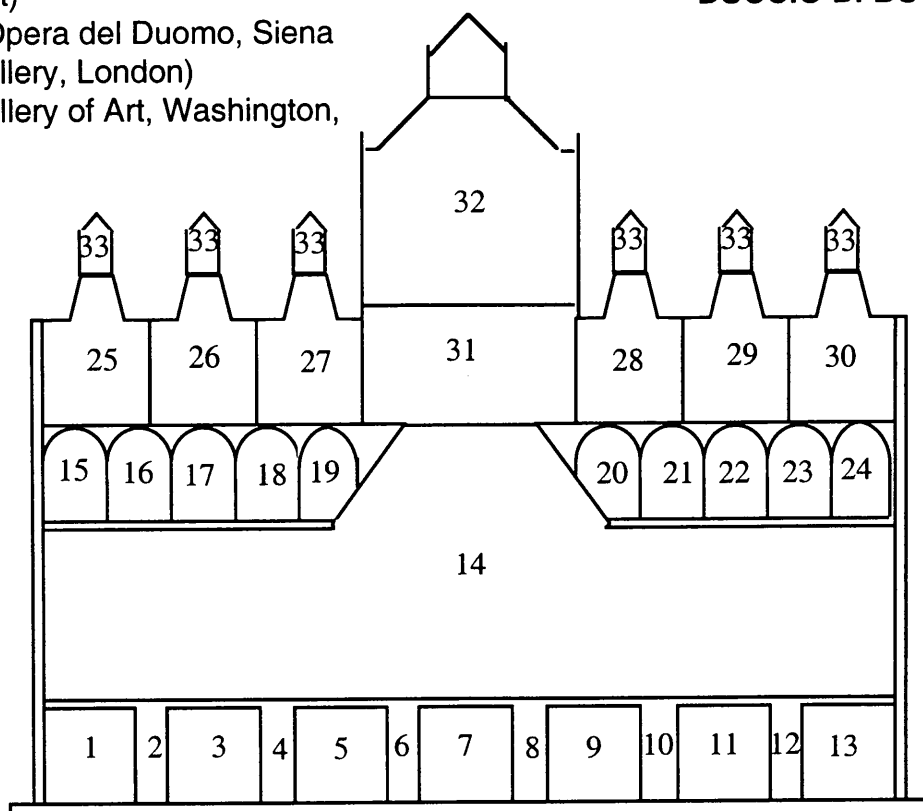

- | | |
|--|---|
| 1. Annunciation (London, NG) | 17. St. Philip |
| 2. Isaiah (Wash., DC, NGA) | 18. St. James Major |
| 3. Nativity (Wash., DC, NGA) | 19. St. Andrew |
| 4. Ezekiel | 20. St. Matthew |
| 5. Adoration of the Magi | 21. St. James Minor |
| 6. Solomon | 22. St. Bartholomew |
| 7. Presentation in the Temple | 23. St. Thomas |
| 8. Malachi | 24. St. Matthias |
| 9. Massacre of the Innocents | 25. Annunciation of the Death of the Virgin |
| 10. Jeremiah | 26. Virgin Bids Farewell to St. John |
| 11. Flight into Egypt | 27. Virgin Bids Farewell to Apostles |
| 12. Hosea | 28. Death of the Virgin |
| 13. Christ among the Doctors | 29. Funeral Procession of the Virgin |
| 14. Virgin Enthroned with
Angels and Saints | 30. Burial of the Virgin |
| 15. St. Thaddeus | 31. Assumption (lost) |
| 16. St. Simon | 32. Coronation of the Virgin (lost) |
| | 33. Angels |

Sources: Deutchler, Florens. *Duccio*. Milan: Electa, 1984.

Dunkerton, Jill, et al. *Giotto to Durer: Early Renaissance Painting in the National Gallery*. New Haven: Yale University Press in association with National Gallery Publications, 1991.

White, John. *Duccio: Tuscan Art and the Medieval Workshop*. London: Thames and Hudson, 1979.

DUCCIO DI BUONINSEGNA

Maesta (back)
 Museo dell'Opera
 del Duomo
 Siena
 1309-11

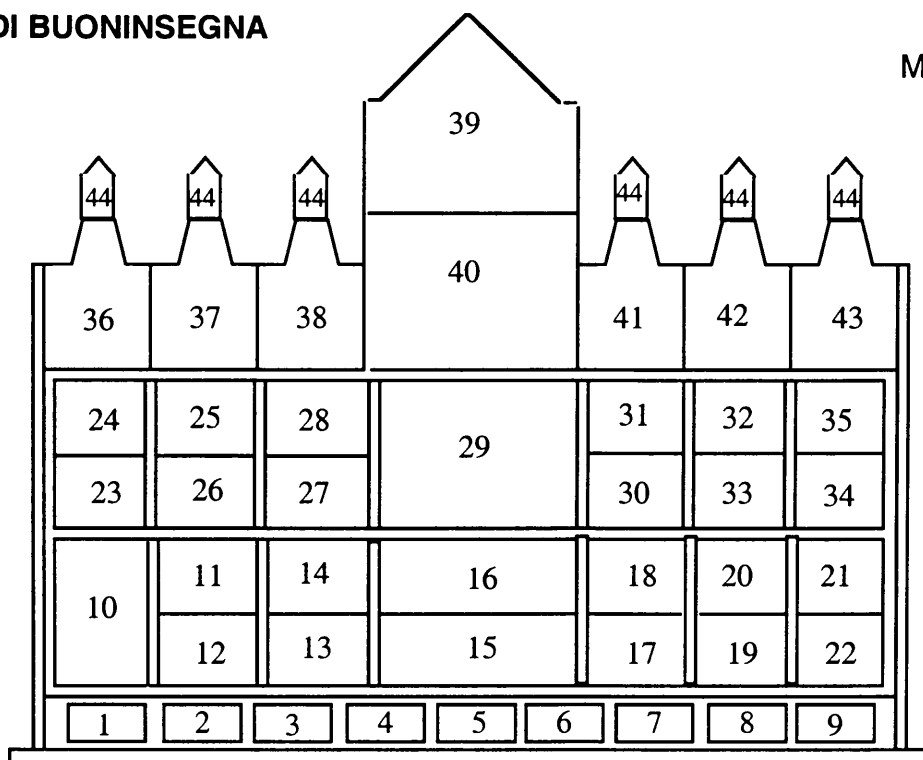

- | | |
|--|--|
| 1. Baptism (lost) | 20. Mocking of Christ |
| 2. Temptation in the Temple | 21. Pharisees Accuse Christ |
| 3. Temptation on the Mount (New York, Frick Collection) | 22. Christ before Pilate |
| 4. Calling of Sts. Peter and Andrew (Wash., DC, NGA) | 23. Christ before Herod |
| 5. Marriage at Cana | 24. Christ in the White Robe before Pilate |
| 6. Christ and the Woman of Samaria (Lugano, Collection Thyssen-Bornemisza) | 25. Flagellation |
| 7. Christ Opens the Eyes of a Man Born Blind (London, NG) | 26. Crowning with Thorns |
| 8. Transfiguration (London, NG) | 27. Pilate Washing his Hands |
| 9. Raising of Lazarus (Fort Worth, Kimbell Art Museum) | 28. Road to Calvary |
| 10. Entry into Jerusalem | 29. Crucifixion |
| 11. Christ Washing the Disciples Feet | 30. Descent from the Cross |
| 12. Last Supper | 31. Entombment |
| 13. Farewell (Discourse) | 32. Three Maries at the Tomb |
| 14. Pact of Judas | 33. Descent into Limbo |
| 15. Agony in the Garden | 34. Noli me tangere |
| 16. Betrayal | 35. Journey to Emmaus |
| 17. First Denial of Peter | 36. Appearance of Christ before Closed Doors |
| 18. Christ before Annas | 37. Incredulity of Thomas |
| 19. Christ before Caiaphas | 38. Appearance at the Sea of Tiberias |
| | 39. Christ in Glory (lost) |
| | 40. Ascension (lost) |
| | 41. Appearance at the Mount |
| | 42. Appearance at the Evening Meal |
| | 43. Pentecost |
| | 44. Angels |

Altarpiece of the Seven Sorrows of the Virgin
Alte Pinakothek, Munich (center panel)
and Gemaldegalerie, Dresden (other panels)
after 1503

**DURER, ALBRECHT
and Assistants?**

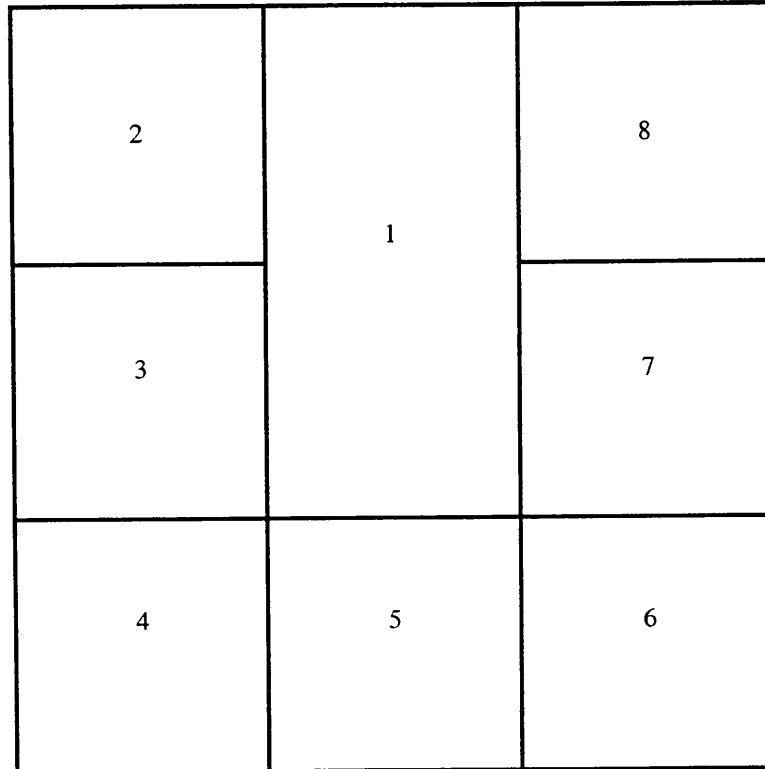

1. Virgin as Mater Dolorosa
2. Circumcision of Christ
3. Flight into Egypt
4. Christ among the Doctors
5. Road to Calvary
6. Nailing to the Cross
7. Crucifixion
8. Lamentation

Source: Strieder, Peter. *Albrecht Durer, Paintings Prints, Drawings*. Rev. ed. New York: Abaris Books, 1989.

**EYCK, JAN VAN
AND HUBERT VAN EYCK**

Ghent Altarpiece
St. Bavo Cathedral, Ghent
1423-32

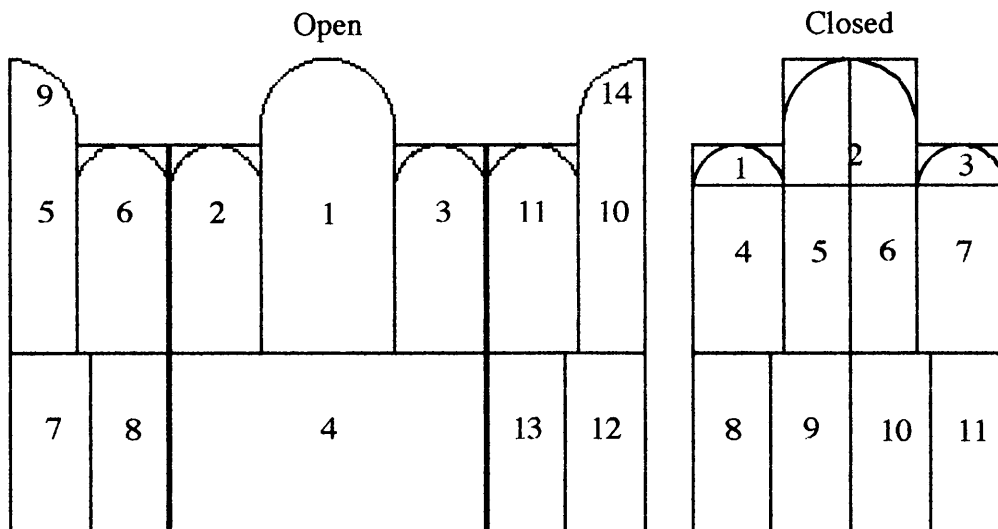

Open, center

1. God the Father
2. Virgin Mary
3. St. John the Baptist
4. Adoration of the Lamb

Left wing

5. Adam
6. Singing Angels
7. Just Judges (copy)
8. Knights of Christ
9. Offering of Abel

Right wing

10. Eve
11. Musical Angels
12. Pilgrims
13. Hermits
14. Slaying of Abel

Closed, upper section

1. Prophet Zacharias
2. Erythraean and Cumaean Sibyls
3. Prophet Micah

Middle section

4. Angel of the Annunciation
5. Window, Antechamber of the Annunciation
6. Aquaminila
7. Virgin of the Annunciation

Lower section

8. Jodocus Vijd
9. St. John the Baptist
10. St. John the Evangelist
11. Elizabeth Boorlunt

Source: Puyvelde, Leo van. *Van Eyck: L'agneau mystique d'Hubert et Jean van Eyck*. Brussels: Elsevier, 1959.

Merode Altarpiece
The Cloisters
New York
c.1426

**FLEMALLE, MASTER OF
(ROBERT CAMPIN)**

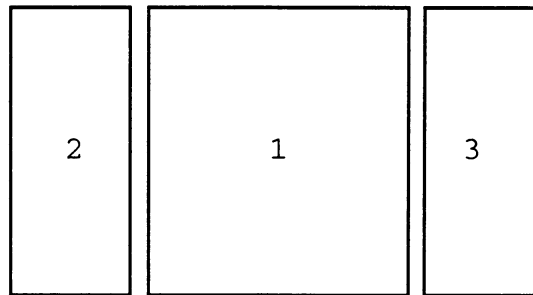

1. Annunciation
2. Donors: Members of the Ingelbrechts Family
and Possibly the Calcum Family
3. Joseph

Source: Cuttler, Charles D. *Northern Painting from Pucelle to Bruegel: Fourteenth, Fifteenth, and Sixteenth Centuries*. New York: Holt, Rinehart and Winston, 1968.

**FLEMALLE, MASTER OF
(ROBERT CAMPIN)**

Von Werl Altarpiece
Prado, Madrid
c.1438

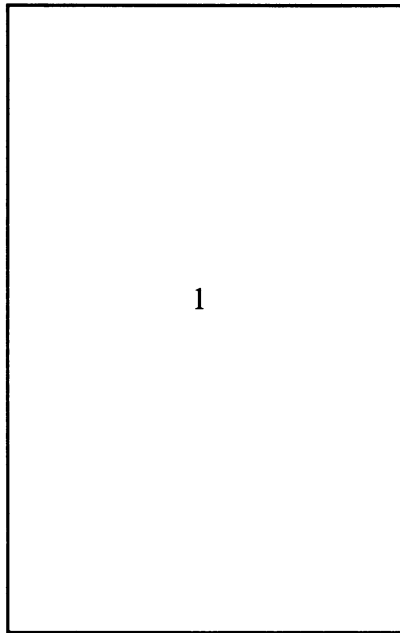

1. St. John the Baptist and
Heinrich von Werl

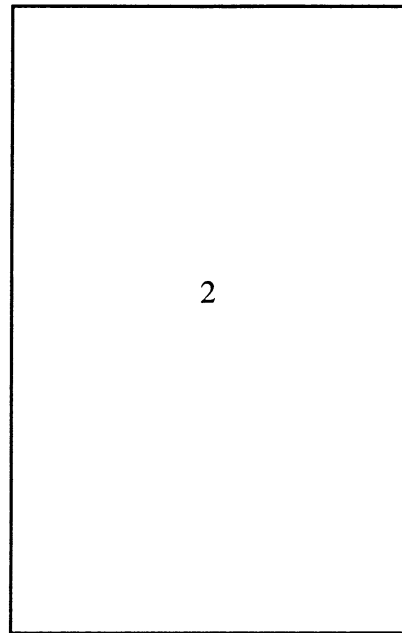

2. St. Barbara

(Evidently two wings of a triptych, the central
panel of which is lost.)

Source: Wehle, Harry Brandeis. *Great Paintings from the Prado Museum*. New York: Harry N. Abrams, 1963.

Legend of the True Cross
Chancel
Santa Croce, Florence
c.1380

GADDI, AGNOLO

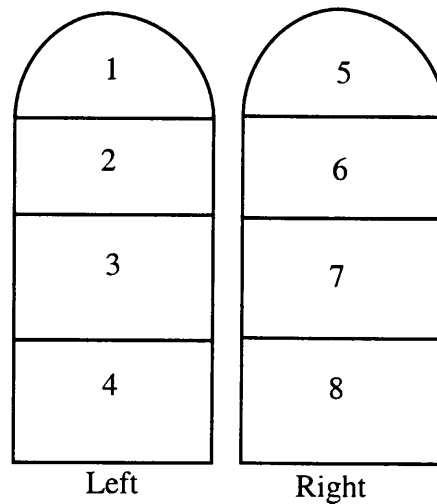

1. Helena Returns the Cross to Jerusalem
2. Theft of the Cross
3. Chosroes Adored by his Subjects; Dream of Heraclius; Battle of Heraclius and the Son of Chosroes
4. Execution of Chosroes; Angel Appears to Heraclius; and Exultation of the Cross
5. Discovery and Proofing of the True Cross
6. Retrieval of the Wood from the Pool of Bethesda and Fabrication of the Cross
7. Sheba Venerates the Wood and Solomon Has the Wood Buried
8. Death of Adam and the Quest of Seth

Sources: Cole, Bruce. *Agnolo Gaddi*. Oxford: Clarendon Press, 1977.

Lavin, Marilyn Aronberg. *The Place of Narrative: Mural Decoration in Italian Churches, 431-1600*. Chicago and London: University of Chicago Press, 1990.

GADDI, TADDEO

Baroncelli Chapel
Santa Croce, Florence
c.1328-30

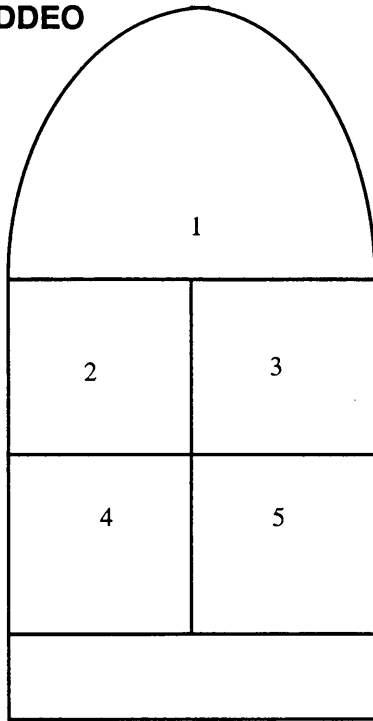

East wall
South

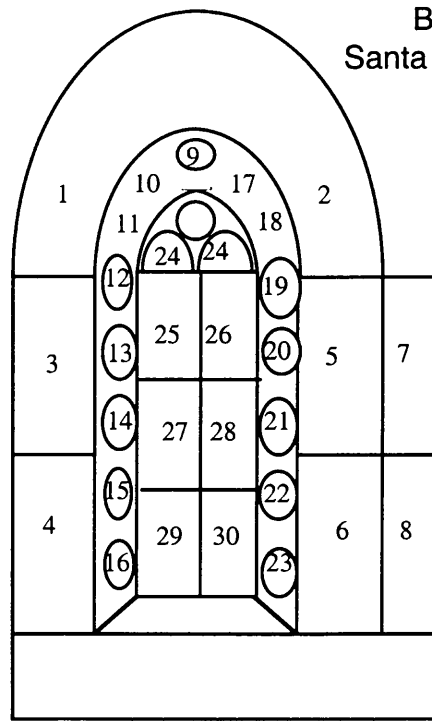

South wall and window

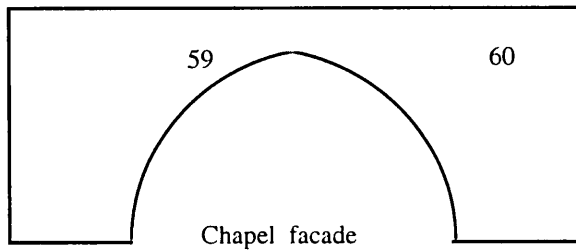
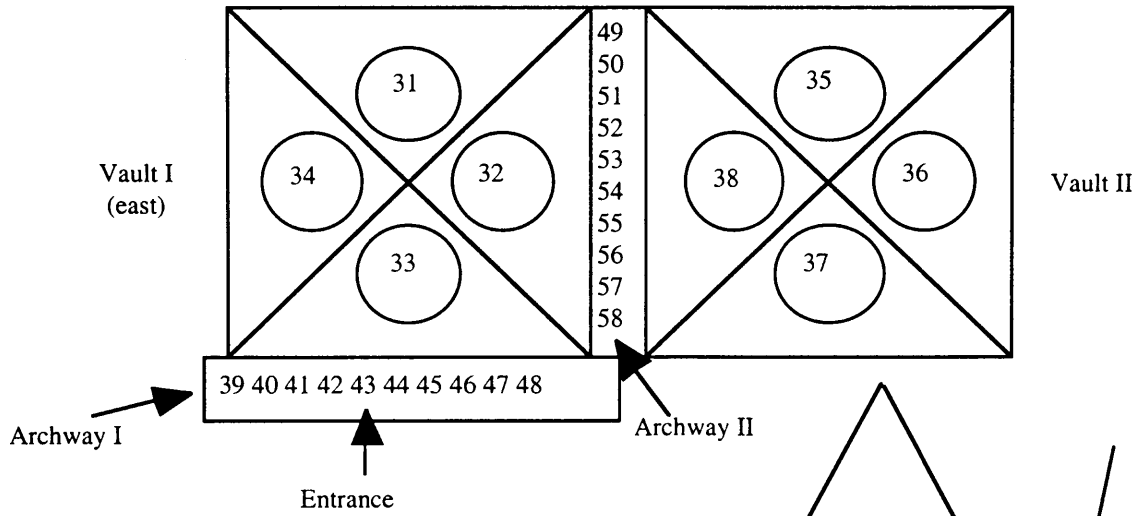

Chapel facade

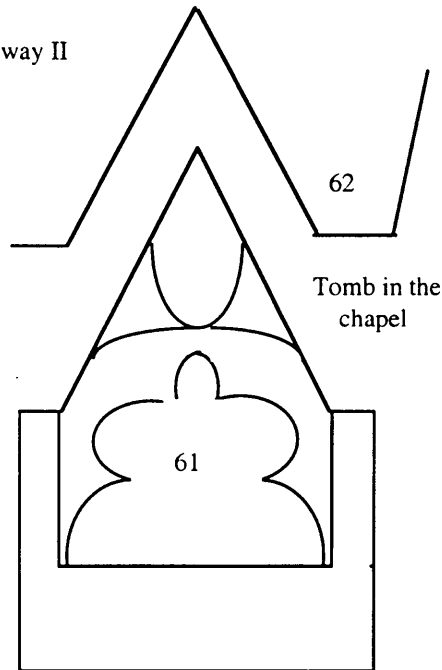

Tomb in the chapel

36

Baroncelli Chapel
 Santa Croce, Florence
 c.1328-30

GADDI, TADDEO

East Wall

1. Expulsion of Joachim and Annunciation to Joachim
2. Meeting at the Golden Gate
3. Birth of the Virgin
4. Presentation in the Temple
5. Marriage of the Virgin

South Wall

1. Annunciation
2. Visitation
3. Annunciation to the Shepherds
4. Adoration of the Shepherds
5. Annunciation of the Magi
6. Adoration of the Magi
7. Jesse
8. David

Roundels in arch around window

9. Faith
10. Hope
11. Humility
12. Temperance
13. Prudence
14. Chastity
15. Obedience
16. Trust in God
17. Charity
18. Misericordia
19. Justice
20. Fortitude
21. Munditia
22. Poverty
23. Fear of God

Windows

24. St. Francis receiving the Stigmata
25. St. Peter
26. St. John the Baptist
27. St. Louis of Toulouse
28. St. Sylvester
29. St. John the Evangelist
30. St. Bartholomew

Vault I

31. Prudence
32. Fortitude
33. Temperance
34. Justice

Vault II

35. Faith
36. Charity
37. Humility
38. Hope

Roundels in archway I

39. David
40. Judith
41. Moses
42. Ruth
43. Gideon
44. Balaam
45. Sheba
46. Aaron
47. Jael
48. Solomon

Roundels in archway II

49. Doctor
50. Doctor
51. Doctor
52. Bonaventure (one of the Doctors of the Church)
53. Virgin
54. Christ
55. John the Baptist
56. Evangelist
57. Evangelist
58. Evangelist

Chapel facade

59. Two Prophets
60. Ezekiel and Daniel

Tomb in the chapel

61. Lunette of Madonna and Child
62. Resurrection

Source: Ladis, Andrew. *Taddeo Gaddi: Critical Reappraisal and Catalogue Raisonné*. Columbia and London: University of Missouri Press, 1982.

**GADDI, TADDEO,
ATTRIBUTED**

Bromley-Davenport
Altarpiece
(Auctioned at Christie's,
London, May 24, 1991)
c.1320

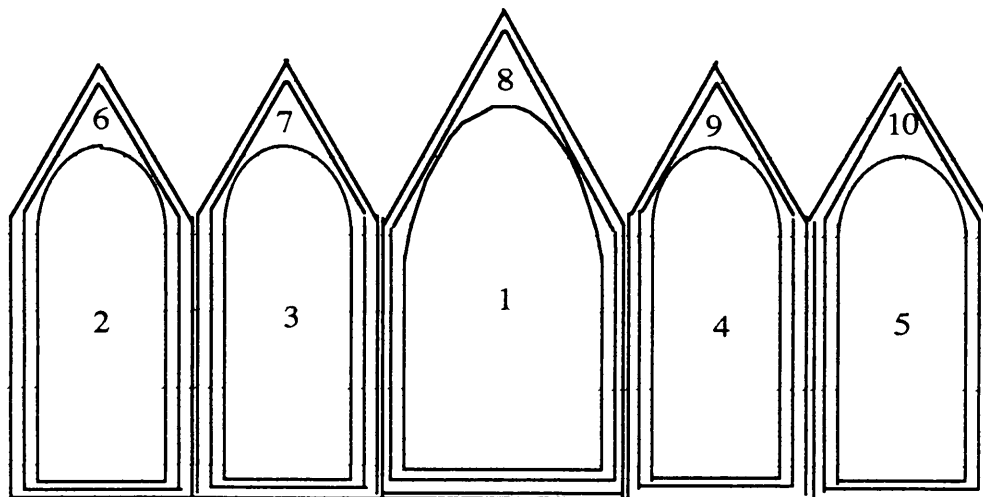

1. Man of Sorrows
2. St. Peter
3. St. Francis
4. St. Paul
5. St. Andrew
6. Prophet
7. Prophet
8. Angels
9. Prophet
10. Prophet

Source: *Important Old Master Pictures, London, Friday, 24 May, 1991*. London: Christie, Mason & Woods International Inc., 1991.

Fresco, detached
 Santa Croce, Refectory (formerly)
 Museo dell' Opera di Santa Croce, Florence
 c.1360

GADDI, TADDEO

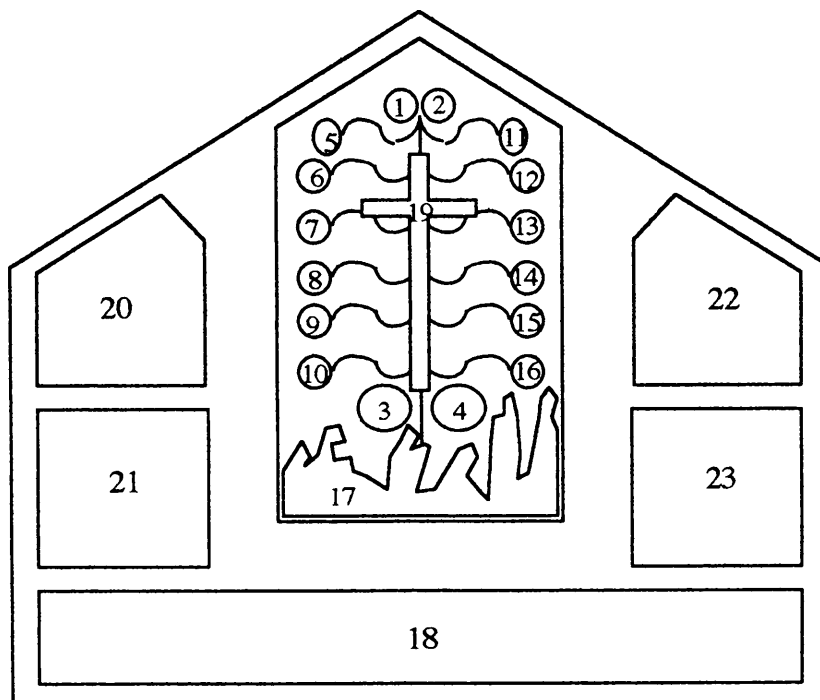

- | | |
|--------------------------|---|
| 1. St. Mark | 16. Prophet Joel |
| 2. St. Matthew | 17. (<i>left-right</i>) Virgin Mary and Three |
| 3. St. Luke | Maries, Female Donor, Sts. John the |
| 4. St. John | Evangelist, Francis, Bonaventure, |
| 5. Prophet Jeremiah | Anthony of Padua, Dominic, Louis of |
| 6. Unidentified Prophet | Toulouse |
| 7. Prophet Zacharias | 18. Last Supper |
| 8. Prophet David | 19. Crucifixion and Tree of Life |
| 9. Unidentified Prophet | 20. Stigmatization |
| 10. Prophet Job | 21. St. Louis Feeding the Poor and Sick at |
| 11. Unidentified Prophet | Santa Croce in Florence |
| 12. Prophet Isaiah | 22. Priest at his Easter Meal Receiving |
| 13. Unidentified Prophet | Word of St. Benedict's Hunger in the |
| 14. Prophet Abdias | Wilderness |
| 15. Prophet Hosea | 23. Magdalene Washing the Feet of Christ |
| | at the House of Simon Pharisee |

Source: Ladis, Andrew. *Taddeo Gaddi: Critical Reappraisal and Catalogue Raisonne*. Columbia and London: University of Missouri Press, 1982.

GENTILE DA FABRIANO

Adoration of the Magi (Strozzi Altarpiece)
(executed for Sacristy of Santa Trinita, Florence)
Uffizi, Florence
completed 1423

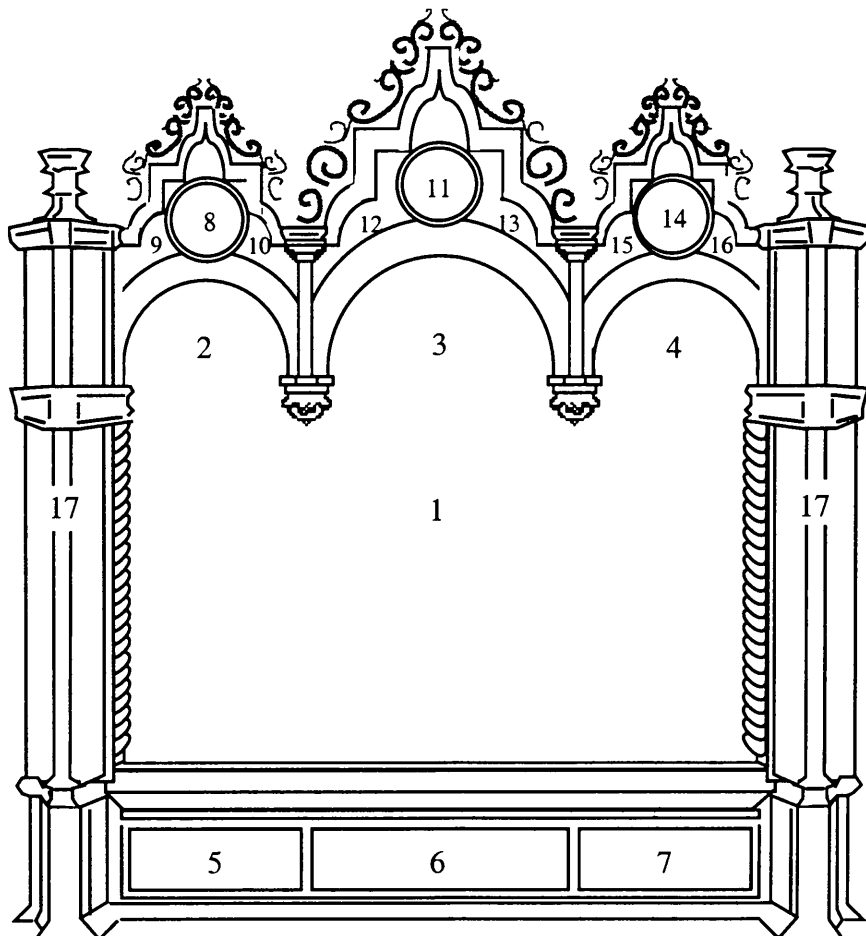

Main panel

1. Adoration of the Magi

Lunettes

2. Sighting of the Star
3. Journey to Jerusalem
4. Entry into Bethlehem

Predella

5. Nativity and Annunciation to the Shepherds
6. Flight into Egypt
7. Presentation in the Temple

Pinnacles

8. Angel of the Annunciation
9. Prophet Ezekiel
10. Prophet Micah
11. Christ Blessing
12. Moses
13. David
14. Virgin of the Annunciation
15. Prophet Baruch
16. Prophet Isaiah

Frame

17. Decorative Panels

Source: Christiansen, Keith. *Gentile da Fabriano*. Ithaca, N.Y.: Cornell University Press, 1982.

Valle Romita Altarpiece
Brera, Milan
c.1410-14

GENTILE DA FABRIANO

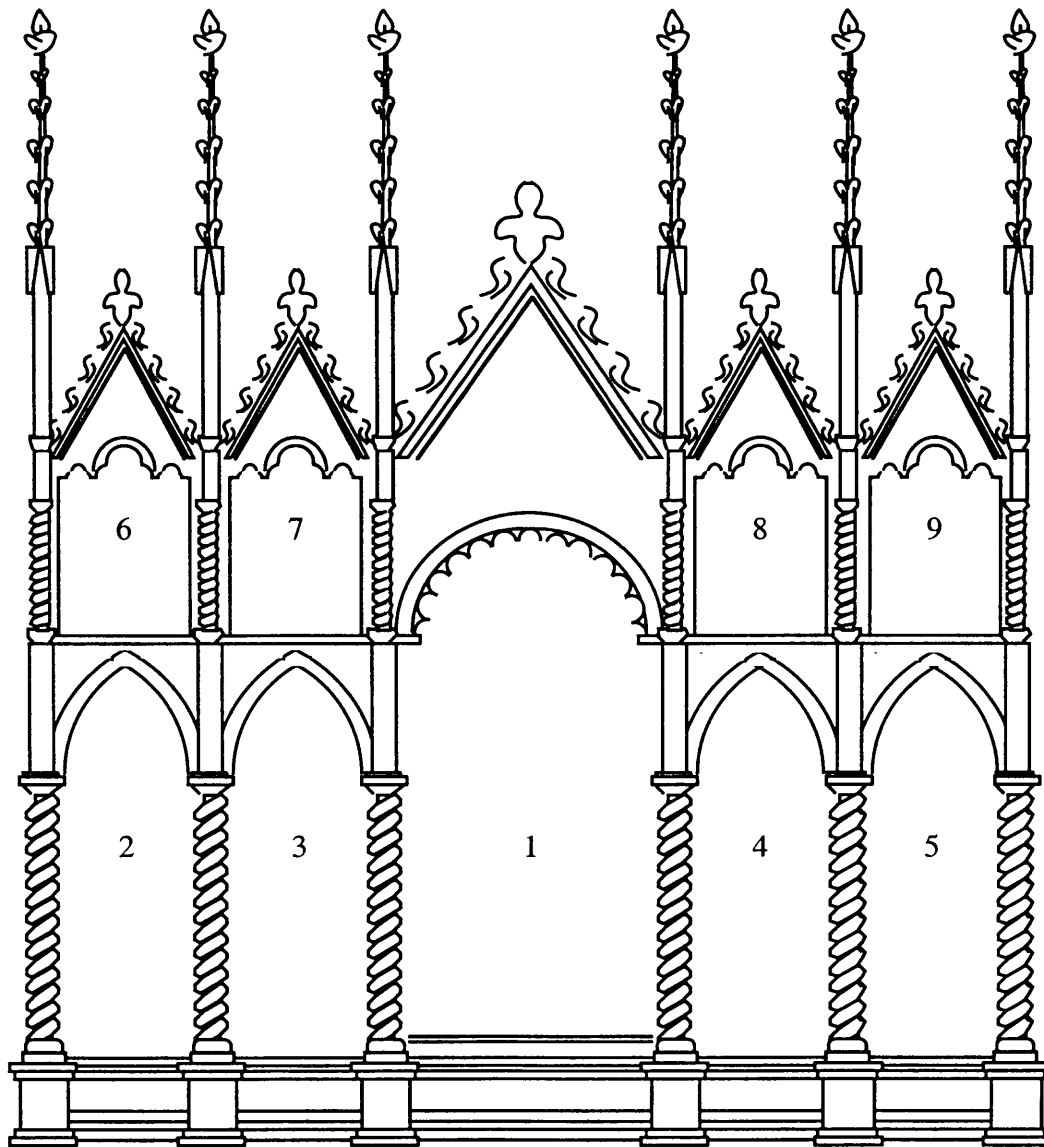

Central panel

1. Coronation of the Virgin

Lower tier

2. St. Jerome

3. St. Francis

4. St. Dominic

5. St. Mary Magdalene

Upper tier

6. St. John the Baptist in the Wilderness

7. Death of St. Peter Martyr

8. A Franciscan Reading

9. Stigmatization

Sources: Christiansen, Keith. *Gentile da Fabriano*. Ithaca, New York: Cornell University Press 1982.

Zampetti, Pietro, and Giampiero Donnini. *Gentile: e i pittori di Fabriano*. Florence: Nardini, 1992.

Ghiberti, Lorenzo

Gates of Paradise (East Doors)
 Cathedral, Baptistry, Florence
 1425-52

1	2
3	4
5	6
7	8
9	10
11	12
13	14

- | | |
|------------------|---------------|
| 1. Eve | 8. Joseph |
| 2. Adam | 9. Moses |
| 3. Genesis | 10. Joshua |
| 4. Cain and Abel | 11. David |
| 5. Noah | 12. Solomon |
| 6. Abraham | 13. Noah |
| 7. Isaac | 14. Puarphera |

Sources: Finn, David, et al. *The Florence Baptistry Doors*. New York: Viking Press, 1980.
 Krautheimer, Richard and Trude Krautheimer-Hess. *Lorenzo Ghiberti*.
 Princeton, New Jersey: Princeton University Press, 1982.

North Doors
Cathedral, Baptistry
Florence
1403-25

GHIBERTI, LORENZO

1	2	3	4
5	6	7	8
9	10	11	12
13	14	15	16
17	18	19	20
21	22	23	24
25	26	27	28

- | | |
|--------------------------|--|
| 1. Road to Calvary | 15. Christ Driving the Money-changers
from the Temple |
| 2. Crucifixion | 16. Christ Walking on the Waves |
| 3. Resurrection | 17. Annunciation |
| 4. Pentecost | 18. Nativity |
| 5. Agony in the Garden | 19. Adoration of the Magi |
| 6. Betrayal | 20. Christ among the Doctors |
| 7. Flagellation | 21. St. John the Evangelist |
| 8. Christ before Pilate | 22. St. Matthew |
| 9. Transfiguration | 23. St. Luke |
| 10. Raising of Lazarus | 24. St. Mark |
| 11. Entry into Jerusalem | 25. St. Augustine |
| 12. Last Supper | 26. St. Jerome |
| 13. Baptism | 27. St. Gregory the Great |
| 14. Temptation of Christ | 28. St. Ambrose |

Source: Finn, David, et al. *The Florence Baptistry Doors*. New York: Viking Press, 1980.

GHIRLANDAIO, DOMENICO

Capella Tornabuoni
 Santa Maria Novella
 Florence
 1485-90

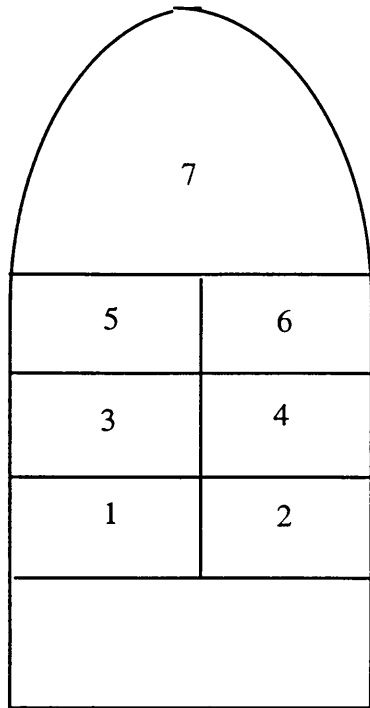

Left wall

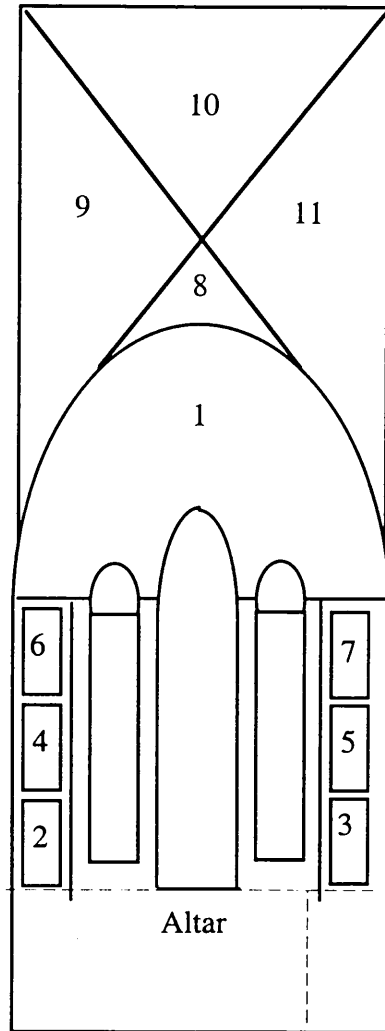

Altar wall and vault

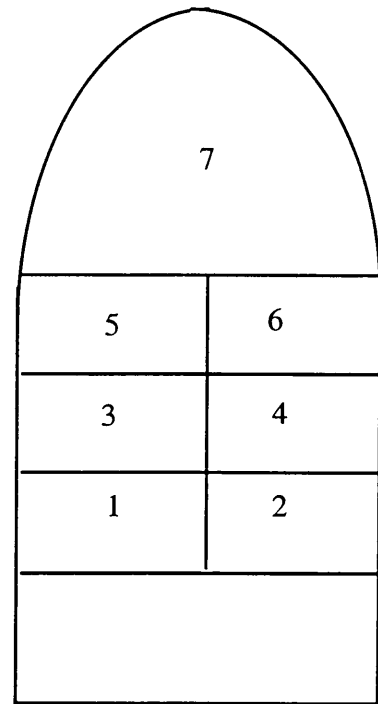

Right wall

Life of the Virgin

1. Expulsion of Joachim from the Temple
2. Birth of the Virgin
3. Presentation of the Virgin
4. Marriage of the Virgin
5. Adoration of the Magi
6. Massacre of the Innocents
7. Death and Assumption of the Virgin

Life of the Virgin

1. Coronation of the Virgin
2. Giovanni Tornabuoni (Donor Portrait)
3. Francesca di Luca Pitti (Donor Portrait)
4. Annunciation
5. St. John the Baptist in the Desert
6. St. Dominic Burning Heretical Books
7. Death of St. Peter Martyr
8. St. John the Evangelist
9. St. Matthew
10. St. Mark
11. St. Luke

Life of John the Baptist

1. Visitation
2. Annunciation to Zacharias
3. Naming of St. John the Baptist
4. Birth of St. John the Baptist
5. Baptism
6. St. John the Baptist Preaching to the Multitude
7. Feast of Herod

Sources: Davies, Gerald Stanley. *Ghirlandaio*. New York: Scribner's, 1909.

Micheletti, Emma. *Domenico Ghirlandaio*. Florence: Scala, 1990.

Prinz, Wolfram, and Max Seidel, eds. *Domenico Ghirlandaio, 1449-1494: atti del convegno internazionale, Firenze, 16-18 ottobre 1994*. Florence: Centro Di, 1996.

Sassetti Chapel
 Santa Trinita, Florence
 1483-85

GHIRLANDAIO, DOMENICO

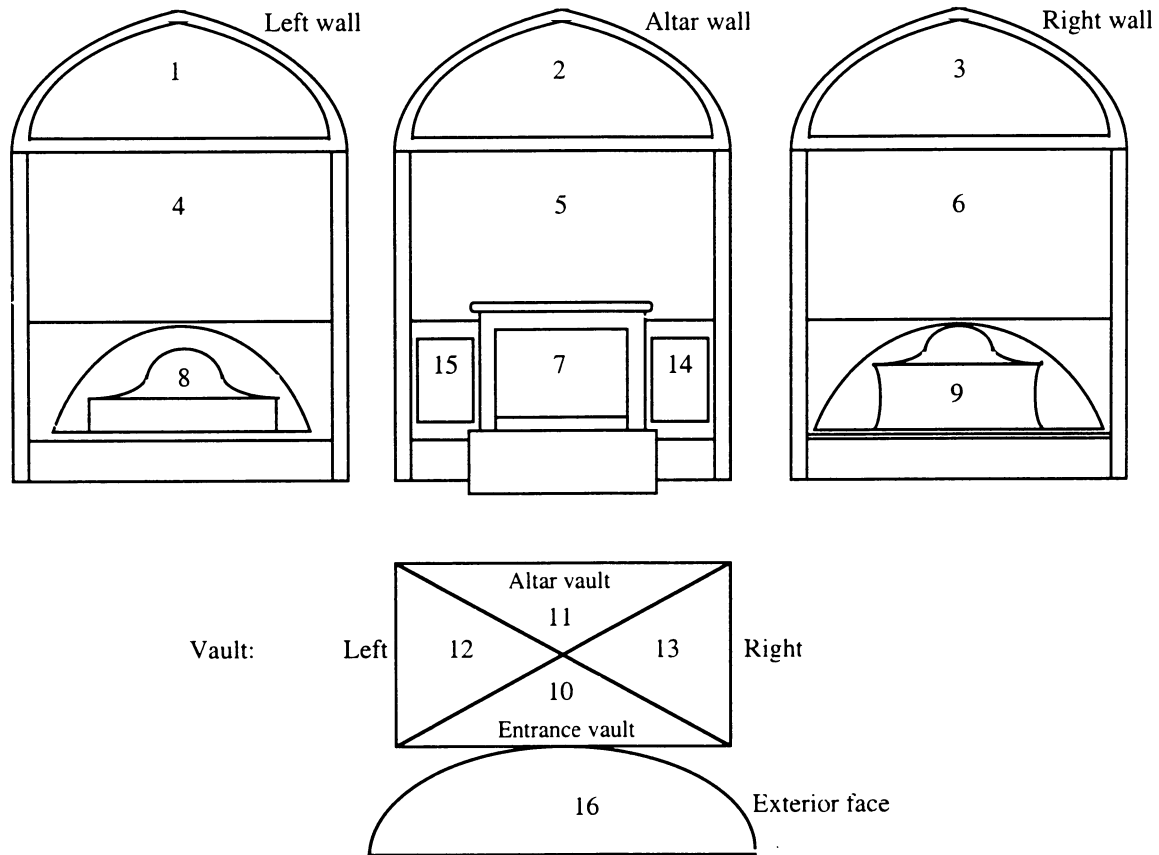

- | | |
|--|---|
| 1. St. Francis Repudiating His Father (with View of Geneva in Background) | 7. Nativity |
| 2. Confirmation of the Rule (with Town Square of Florence with the City Hall and Loggia dei Signori in Background) | 8. Tomb of Nera Corsi Sassetti |
| 3. Trial by Fire | 9. Tomb of Francesco Sassetti |
| 4. Stigmatization (with View of La Verna Rendered as Pisa) | 10. Cumaean Sibyl |
| 5. St. Francis Raising the Roman Notary's Son (with View of Piazza Santa Trinita in Florence) | 11. Eritrean Sibyl |
| 6. Funeral of St. Francis | 12. Cimmerian Sibyl (?) |
| | 13. Agrippan Sibyl |
| | 14. Francesco Sassetti |
| | 15. Nera Corsi Sassetti |
| | 16. Vision of Augustus on the Capitoline Hill |

Source: Borsook, Eve and Johannes Offerhaus. *Francesco Sassetti and Ghirlandaio at Santa Trinita, Florence: History and Legend in a Renaissance Chapel*. Doornspijk, Holland: Davaco Publishers, 1981.

GIOTTO

Arena Chapel, Padua
1304-13

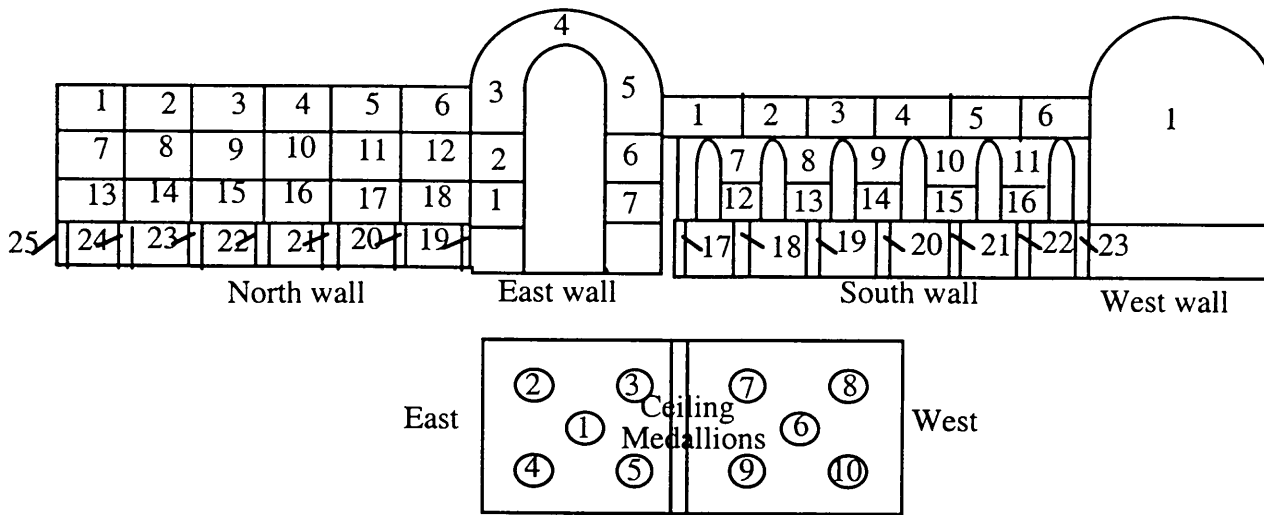

North wall

1. Birth of the Virgin
2. Presentation of the Virgin
3. Presentation of the Rods
4. Prayer of the Suitors
5. Marriage of the Virgin
6. Bridal Procession
7. Christ among the Doctors
8. Baptism
9. Marriage at Cana
10. Raising of Lazarus
11. Entry into Jerusalem
12. Christ Driving the Money changers from the Temple
13. Road to Calvary
14. Crucifixion
15. Lamentation
16. Resurrection and Noli me tangere
17. Ascension
18. Pentecost

South wall

1. Joachim Cast out of the Temple
2. Joachim's Return to the Sheepfold
3. Annunciation to Anne
4. Sacrifice of Joachim
5. Vision of Joachim
6. Meeting at the Golden Gate
7. Nativity
8. Adoration of the Magi
9. Presentation in the Temple
10. Flight into Egypt
11. Massacre of the Innocents
12. Last Supper
13. Christ Washing the Disciples' Feet
14. Betrayal
15. Christ before Caiaphas
16. Mocking of Christ

South wall: Virtues

17. Prudence
18. Fortitude
19. Temperance
20. Justice
21. Faith
22. Charity
23. Hope

North wall: Vices

19. Folly
20. Inconstancy
21. Wrath
22. Injustice
23. Infidelity
24. Envy
25. Despair

West wall

1. Last Judgment

East wall

1. Perspective of Chapel
2. Judas Receiving the Bribe
3. Angel of the Annunciation
4. God Sending Gabriel
5. Virgin of the Annunciation
6. Visitation
7. Perspective of the Chapel

Ceiling medallions

1. Madonna and Child
2. Malachi
3. Isaiah
4. Daniel
5. Baruch
6. Christ
7. Prophet
8. Prophet
9. St. John the Baptist
10. Prophet

Sources: Baccheschi, Edi. *The Complete Paintings of Giotto*. New York: Harry N. Abrams, 1966; London: Weidenfeld and Nicolson, 1969.

White, John. *Art and Architecture in Italy, 1250-1400*. 1st ed. Harmondsworth, Middlesex: Penguin Books, 1966.

Bardi Chapel
 Santa Croce, Florence
 c.1315-20(?)

GIOTTO

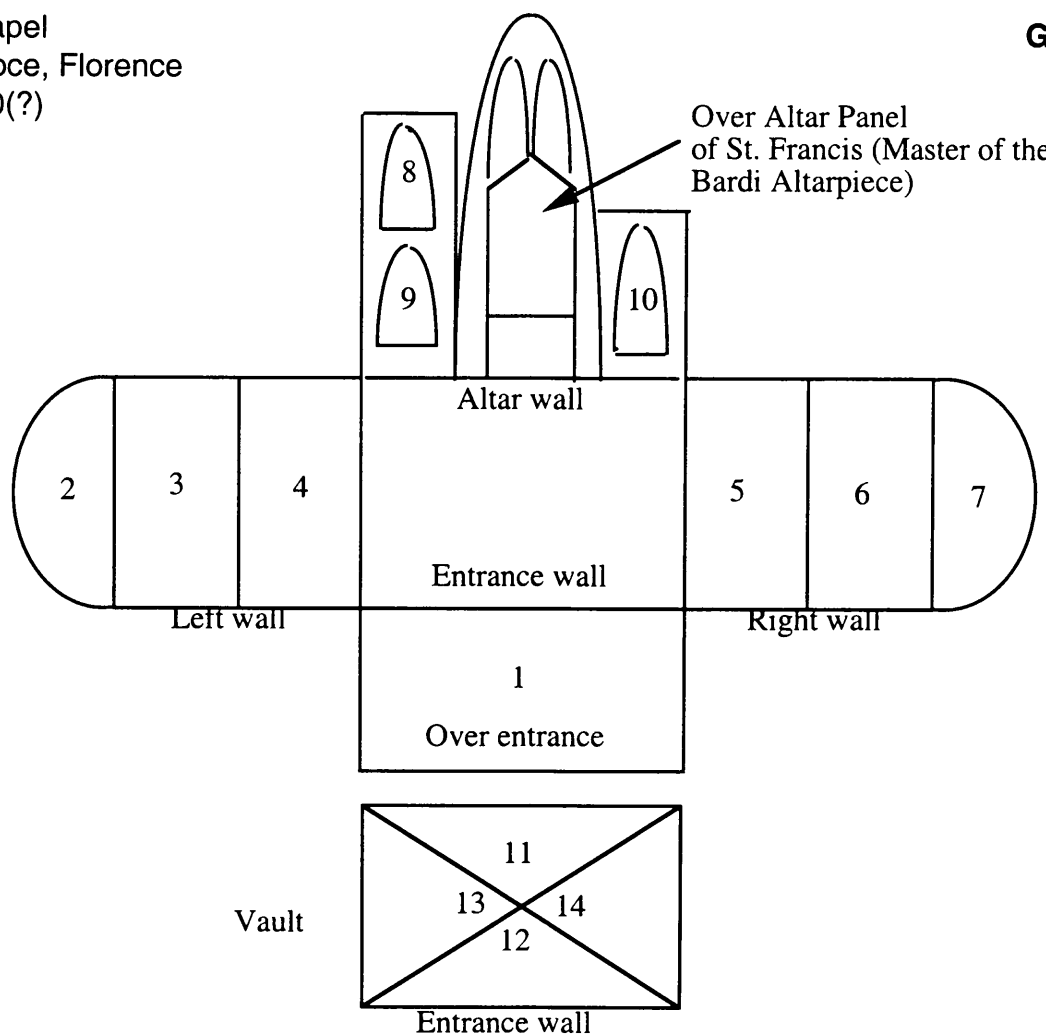

Walls

- | | |
|---|--|
| 1. Stigmatization | 8. St. Louis of Toulouse |
| 2. St. Francis Repudiating His Father | 9. St. Clare |
| 3. Apparition at Arles | 10. St. Elizabeth of Hungary |
| 4. Death of St. Francis and Confirmation of the Stigmata | <u>Vaults</u> |
| 5. Visions of St. Francis's Death to Fra Agostino and to the Bishop of Assisi | 11. St. Francis in Glory (?) destroyed |
| 6. Trial by Fire | 12. Allegory of Chastity |
| 7. Confirmation of the Rule | 13. Allegory of Poverty |
| | 14. Allegory of Obedience |

Sources: Baccheschi, Edi. *The Complete Paintings of Giotto*. New York: Harry N. Abrams, 1966; London: Weidenfeld and Nicolson, 1969.
 Moleta, Vincent. *From St. Francis to Giotto: The Influence of St. Francis on Early Italian Art and Literature*. Chicago: Franciscan Herald Press, 1983.
 Previtali, Giovanni. *Giotto e la sua bottega*, 2nd ed. Milan: Fratelli, Fabbri, 1967.
 Schneider, Laurie, ed. *Giotto in Perspective*. Englewood Cliffs, New Jersey: Prentice Hall, 1974.
 White, John. *Art and Architecture in Italy, 1250-1400*. 2nd ed. Harmondsworth, Middlesex: Penguin Books, 1987.

GIOTTO

Peruzzi Chapel
Santa Croce, Florence
mid 1320s

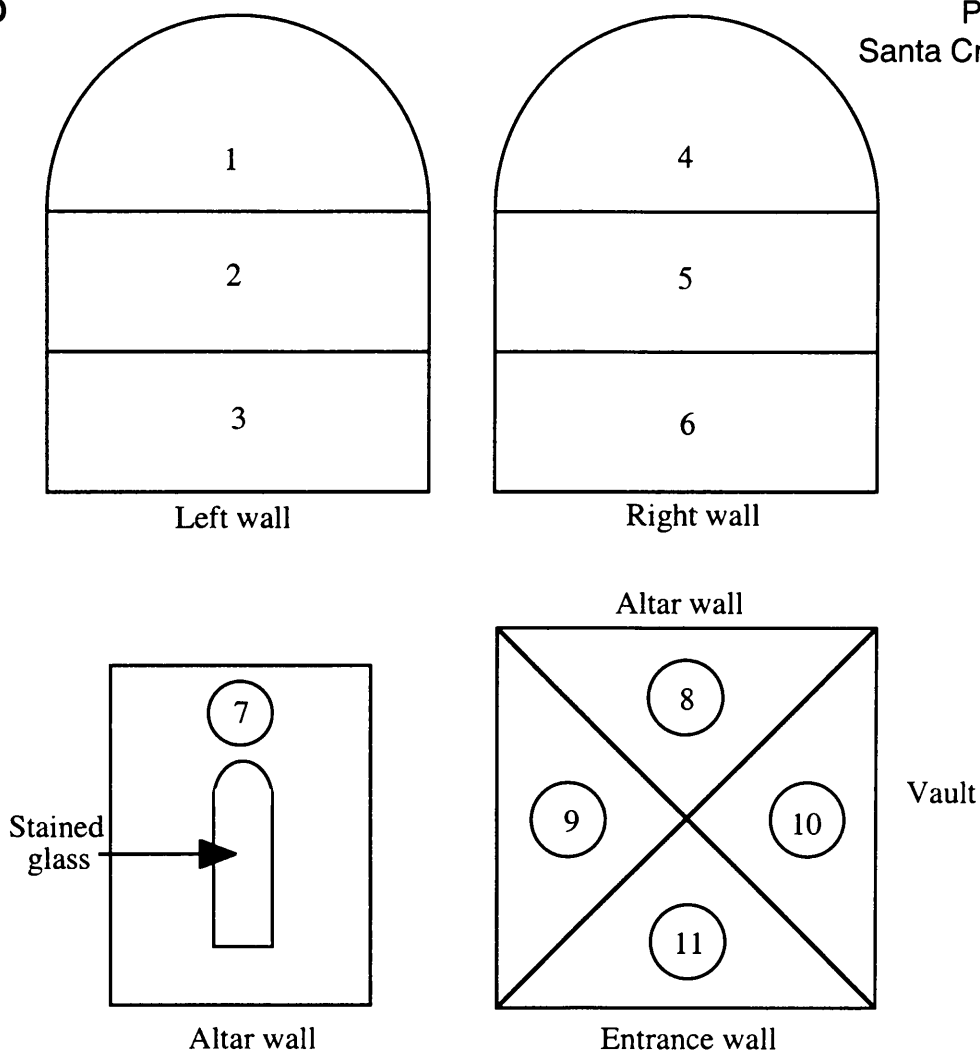

Left wall: St. John the Baptist

1. Annunciation to Zacharias
2. Birth and Naming of St. John the Baptist
3. Banquet of Herod and Dance of Salome

Right wall: St. John the Evangelist

4. St. John the Evangelist on Patmos
5. Resurrection of Drusiana
6. Ascension of St. John the Evangelist

Altar wall

7. Apocalyptic Lamb

Vault Symbols of the Evangelists

8. Lion
9. Eagle
10. Bull
11. Angel

Sources: Baccheschi, Edi. *The Complete Paintings of Giotto*. New York: Harry N. Abrams, 1966; London: Weidenfeld and Nicholson, 1969.

Previtali, Giovanni. *Giotto e la sua bottega*. 2nd ed. Milan: Fratelli Fabbri, 1967.

Schneider, Laurie, ed. *Giotto in Perspective*. Englewood Cliffs, New Jersey: Prentice-Hall, 1974.

Tintori, Leonetto and Eve Borsook. *Giotto: The Peruzzi Chapel*. Turin: Edizioni d'arte Fratelli Pozzo, 1965.

White, John. *Art and Architecture in Italy, 1250-1400*. 2nd ed. Harmondsworth, Middlesex: Penguin Books, 1987.

Legend of St. Francis, Old and
New Testament Cycles
Upper Church, San Francesco
Assisi
mid-1290s

**GIOTTO
and Others**

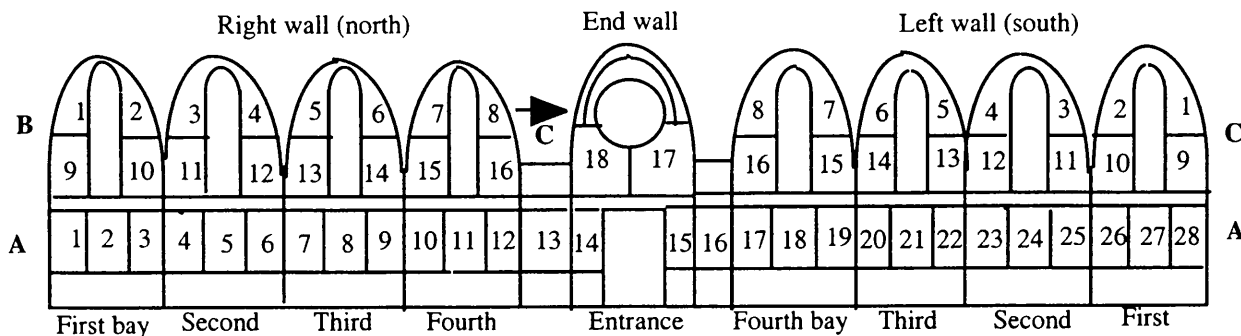

A. Legend of St. Francis

1. St. Francis and the Madman of Assisi
2. St. Francis Giving Away His Cloak
3. Dream of the Palace
4. St. Francis before the Crucifix in S. Damiano
5. St. Francis Repudiating His Father
6. Dream of Innocent III
7. Confirmation of the Rule
8. Vision of the Fiery Chariot
9. Vision of Fra Leone
10. Stigmatization
11. Trial by Fire
12. St. Francis in Ecstasy
13. Institution of the Crib at Greccio
14. Miracle of the Spring
15. St. Francis Preaching to the Birds
16. Death of the Knight of Celano
17. St. Francis Preaching before Honorius III
18. Apparition at Arles
19. Stigmatization
20. Death of St. Francis
21. Apparition of St. Francis
22. Verification of the Stigmata

23. Mourning of the Clares

24. Canonization of St. Francis
25. Dream of Gregory IX
26. Healing of the Man at Ilerda
27. Resuscitation of a Woman
28. Liberation of Peter the Heretic

B. Old Testament Series (right wall)

1. Creation of the World
2. Creation of Adam
3. Creation of Eve
4. The Fall
5. Expulsion
6. Adam and Eve Labor (destroyed)
7. Sacrifices of Cain and Abel (destroyed)
8. Cain Killing Abel
9. Building of the Ark
10. The Ark
11. Sacrifice of Abraham
12. Abraham and the Three Angels
13. Isaac and Jacob
14. Isaac and Esau
15. Jacob Lowered into the Well
16. Jacob and His Brothers

C. New Testament Series (left wall)

1. Annunciation
2. Visitation (destroyed)
3. Nativity
4. Adoration of the Child
5. Presentation in the Temple
6. Flight into Egypt
7. Christ among the Doctors
8. Baptism
9. Marriage at Cana
10. Raising of Lazarus
11. Betrayal
12. Flagellation (?)
13. Road to Calvary
14. Crucifixion
15. Lamentation
16. Resurrection and the Holy Women
17. Ascension
18. Pentecost

Sources: Bellosi, Luciano. *Giotto*. Florence: Scala Istituto Fotografico Editoriale, 1981.

Moleta, Vincent. *From St. Francis to Giotto: The Influence of St. Francis on Early Italian Art and Literature*. Chicago: Franciscan Herald Press, 1983.

Poeschke, Joachim. *Die Kirche San Francesco in Assisi und ihre Wandmalereien*. Munich: Hirmer Verlag, 1985.

White, John. *Art and Architecture in Italy, 1250-1400*. 1st ed. Harmondsworth, Middlesex: Penguin Books, 1966.

**GIOTTO
and Followers**

St. Francis Series
Nave Crossing Vault
Lower Church
San Francesco
Assisi
c.1320

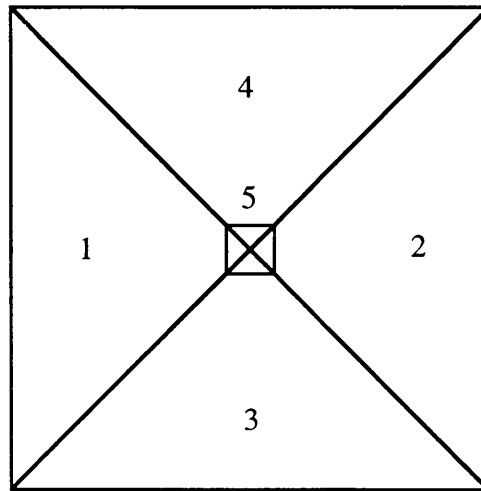

1. Allegory of Chastity
2. Allegory of Obedience
3. Allegory of Poverty
4. Glorification of St. Francis
5. Apocalyptic Christ

Sources: Cottier, Jean-Pierre. *"Le Vele" nella basilica inferiore di Assisi: saggio e analisi*. Florence: Edam, 1981.

Poeschke, Joachim. *Die Kirche San Francesco in Assisi und ihre Wandmalereien*. Munich: Hirmer Verlag, 1985.

Presentation in the Temple
Pinacoteca, Siena
c.1447-49

GIOVANNI DI PAOLO

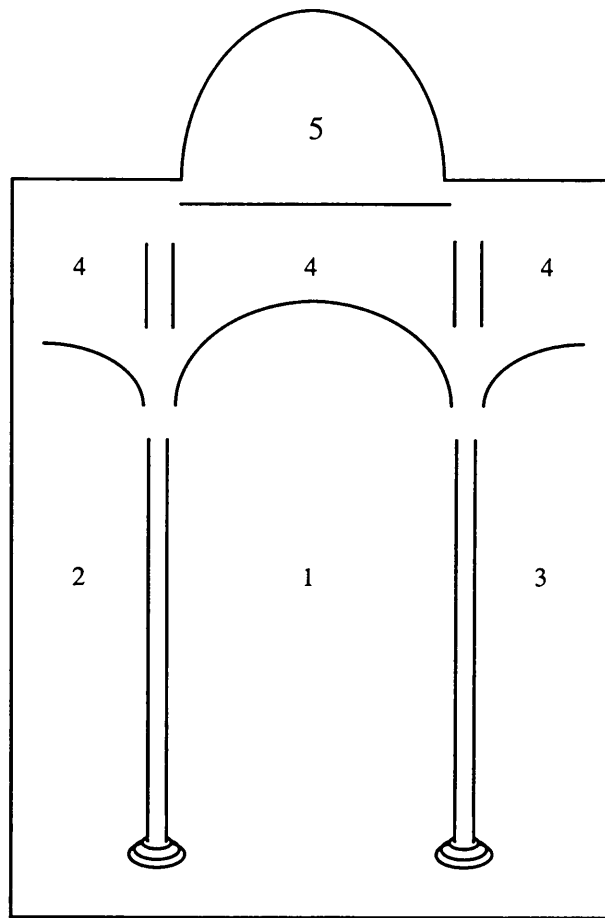

1. Presentation in the Temple
2. St. Joseph
3. Prophetess Anna
4. Statues and Garlands
5. Dome

Source: Marle, Raimond van. *The Development of the Italian Schools of Painting*, Vol. 9. *Late Gothic Painting in Tuscany*. The Hague: Martinus Nijhoff, 1927.

**GIOVANNI DI PAOLO
and Pupils**

Assumption of the Virgin with Saints
(Staggia Altarpiece)
(formerly San Silvestro near Staggia)
Pinacoteca, Siena
c.1475

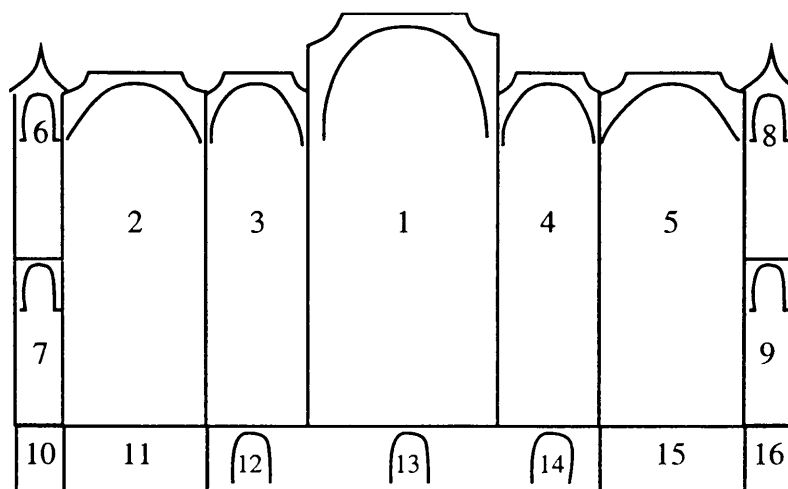

1. Assumption
2. St. Bernadino of Siena
3. St. John the Baptist
4. St. George
5. St. Gregory the Great or St. Sylvester (?)
6. St. Sebastian
7. St. Francis
8. St. Paul
9. St. Sylvester or Pope Fabian (?)
10. Donor
11. St. Mary Magdalene
12. Virgin
13. Man of Sorrows
14. St. John the Evangelist
15. St. Anthony Abbot
16. St. William (?)

Source: Pope-Hennessy, John W. *Giovanni di Paolo*. London: Chatto and Windus, 1937.
Notes sent by Tina Bissell, University of Michigan, May 17, 1993.

Sala di Constantino (walls)
Vatican Museums, Vatican City
1521-25

GIULIO ROMANO
GIOVANNI FRANCESCO
PENNI
and **RAFFAELLINO DEL**
COLLE

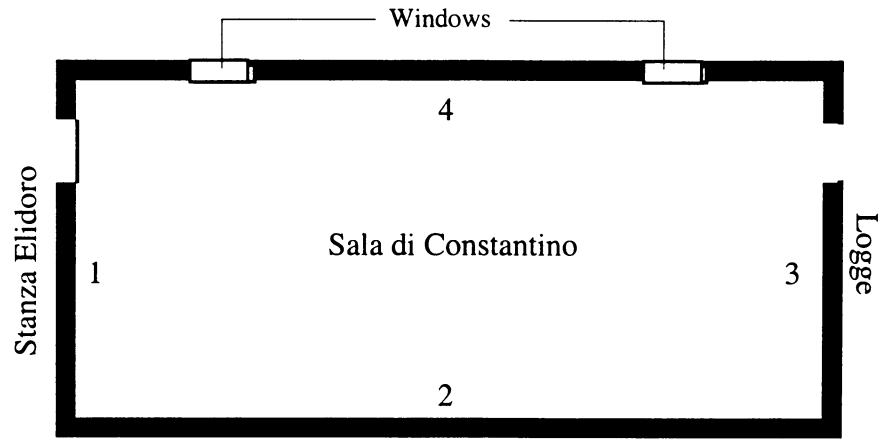

1. Giulio Romano. Constantine Addressing Soldiers and Vision of the Cross. 1521
To left, St. Peter, the Church and Eternity
To right, Clement I, Temperance and Meekness
2. Giulio Romano. Victory of Constantine over Maxentius at the Milvian Bridge. 1521
To left, Sylvester I, Faith and Religion
To right, Urban I, Justice and Charity
3. Giovanni Francesco Penni. Baptism of Constantine. 1524-25
To left, Damasus I, Prudence and Peace
To right, Leo I, Innocence and Truth
4. Giulio Romano. Constantine's Donation of Rome to Sylvester. 1523-24
To left, Sylvester I and Courage
To right, Gregory I and Fortitude

Sources: Cornini, Guido, et al, ed. *Raphael in the Apartments of Julius II and Leo X.: Papal Monuments, Museums, Galleries*. Milan: Electa, c.1993.

Gombrich, Ernst, et al. *Giulio Romano*. 2 vols. Milan: Electra, 1989.

Jones, Roger and Nicholas Penny. *Raphael*. New Haven: Yale University Press, 1983.

Macadam, Alta, ed. *Rome and Environs*. London: Benn, 1979.

**GIULIO ROMANO
GIOVANNI FRANCESCO PENNI
and Assistants**

Sala de Psyche Ceiling
Palazzo del Te
Mantua
c.1528

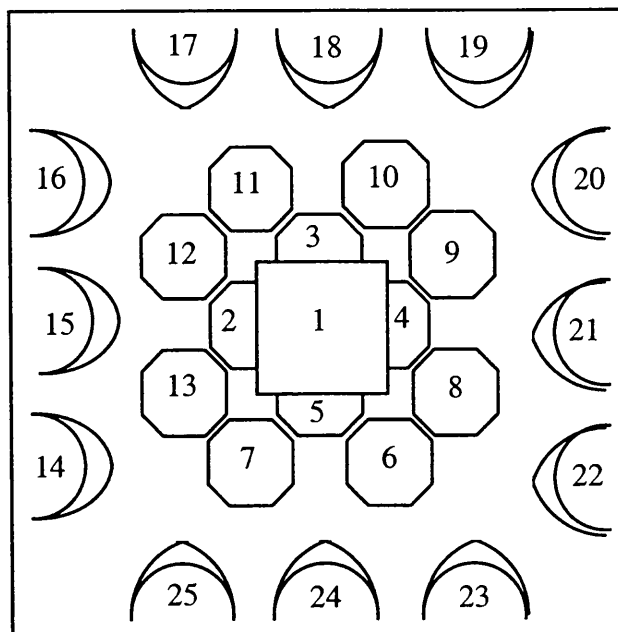

Ceiling center

1. Wedding of Cupid and Psyche

Half octagons

2. Cupid
3. One of the Graces
4. One of the Graces
5. Giovanni Francesco Penni after design of Giulio Romano. One of the Graces

Octagons

6. Giovanni Francesco Penni after design of Giulio Romano. Psyche Worshipped as a Goddess
7. Venus Pointing Out Psyche to Cupid
8. Giovanni Francesco Penni after design of Giulio Romano. Psyche and Her Father Consult the Oracle
9. Psyche Wafted over the Sea by Zephyrus
10. Psyche Served by Unseen Hands in Cupid's Palace
11. Giovanni Francesco Penni after design of Giulio Romano. Psyche Asleep in Cupid's Garden
12. Giovanni Francesco Penni after design of

Giulio Romano. Psyche Bestowing Gifts upon Her Jealous Sisters

13. Psyche Holds the Lamp over Cupid

Lunettes

14. Venus Chides Cupid
15. Venus Reproved for Her Severity by Juno and Ceres
16. Psyche Appeals to Ceres
17. Psyche Appeals to Juno
18. Mercury Publishes the Proclamation of Venus
19. Venus before Jupiter
20. Psyche Captured by Consuetudo and Scourged by Sollicitudo and Tristitia
21. Ants Separate Grain for Psyche
22. Labor of the Golden Fleece
23. Cupid Awakens Psyche from Her Deadly Sleep
24. Jove's Eagle Brings Psyche Water from Styx
25. Psyche Receiving Vase Containing Proserpina's Beauty

Vaulting compartments above lunettes

Amorini, mostly by Giulio Romano (in oil)

Source: Cole, Alison. *Virtue and Magnificence: Art of the Italian Renaissance Courts*. New York: Harry N. Abrams, 1995.

Hartt, Frederick. *Giulio Romano*. 2 vols. New Haven: Yale University Press, 1958.

Portinari Altarpiece
Florence, Uffizi
c.1473-76

GOES, HUGO VAN DER

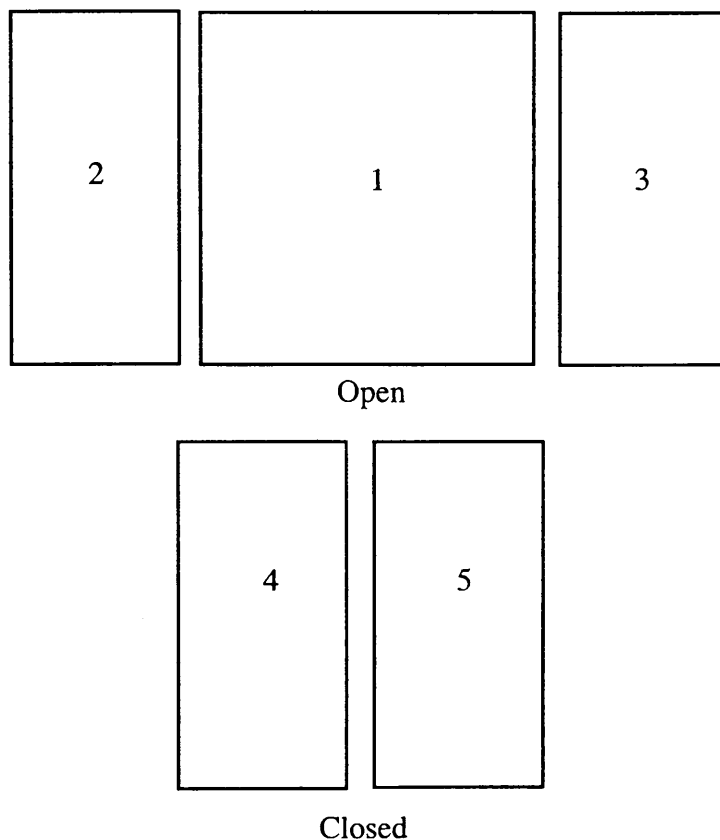

1. Adoration of the Shepherds
2. Sts. Anthony Abbot and Thomas with Tommaso Portinari and His Two Sons
3. Sts. Margaret and Mary Magdalene with Maria Baroncelli and Her Daughter
4. Virgin of the Annunciation
5. Angel of the Annunciation

Source: Blum, Shirley Neilsen. *Early Netherlandish Triptychs: A Study in Patronage*. Berkeley and Los Angeles: University of California Press, 1969.

Panofsky, Erwin. *Early Netherlandish Painting, Its Origins and Character*. 2 vols. Cambridge: Harvard University Press, 1966.

GOZZOLI, BENOZZO

Scenes from the Life of St. Francis
 St. Francis in Glory, Franciscan Saints
 Museo Communale of San Francesco
 Choir Chapel, Montefalco
 1452

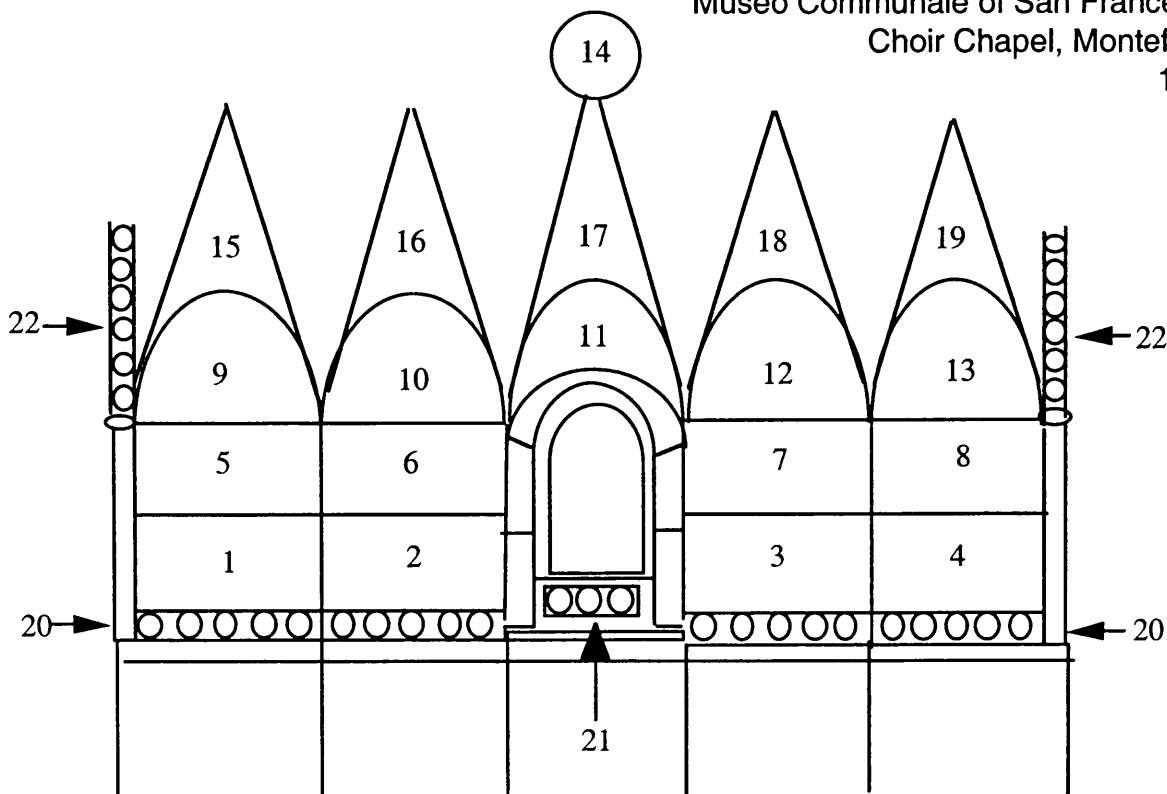

- | | |
|---|--|
| <ol style="list-style-type: none"> 1. Birth of St. Francis and Christ as Pilgrim before Parents' Door; and St. Francis Spreading His Cloak 2. St. Francis Giving Away His Cloak and St. Francis Dreams of a Heavenly Fortress 3. St. Francis Repudiating His Father and Bishop of Assisi Clothes St. Francis 4. Vision of St. Dominic and Meeting of St. Dominic and St. Francis 5. Dream of Innocent III and Confirmation of the Rule 6. St. Francis and the Demons of Arezzo 7. St. Francis Preaching to the Birds and Blessing the Bishop and Dignitaries of Montefalco 8. Death of the Knight of Celano | <ol style="list-style-type: none"> 9. Institution of the Crib at Greccio 10. Trial by Fire 11. Stigmatization 12. Stigmatization 13. St. Francis Ascends into Heaven; Death of St. Francis 14. St. Francis in Glory 15. St. Louis of Toulouse 16. St. Elizabeth of Hungary 17. St. Bernardino of Siena 18. St. Clare of Assisi 19. St. Anthony of Padua 20. Tetricians 21. Petrarch; Dante; Giotto 22. St. Francis and His Twelve Companions (soffits) |
|---|--|

Sources: Lavin, Marilyn Aronberg. *The Place of Narrative: Mural Decoration in Italian Churches, 431-1600*. Chicago and London: University of Chicago Press, 1990.

Padoa Rizzo, Anna. *Benozzo Gozzoli pittore fiorentino*. Florence: Edam, 1972.

Roettgen, Steffi. *Italian Frescoes. Vol.1, The Early Renaissance, 1400-1470*. New York, London and Paris: Abbeville Press, 1996.

Procession of the Magi
 Palazzo Medici-Riccardi
 Florence
 1459-?

GOZZOLI, BENOZZO

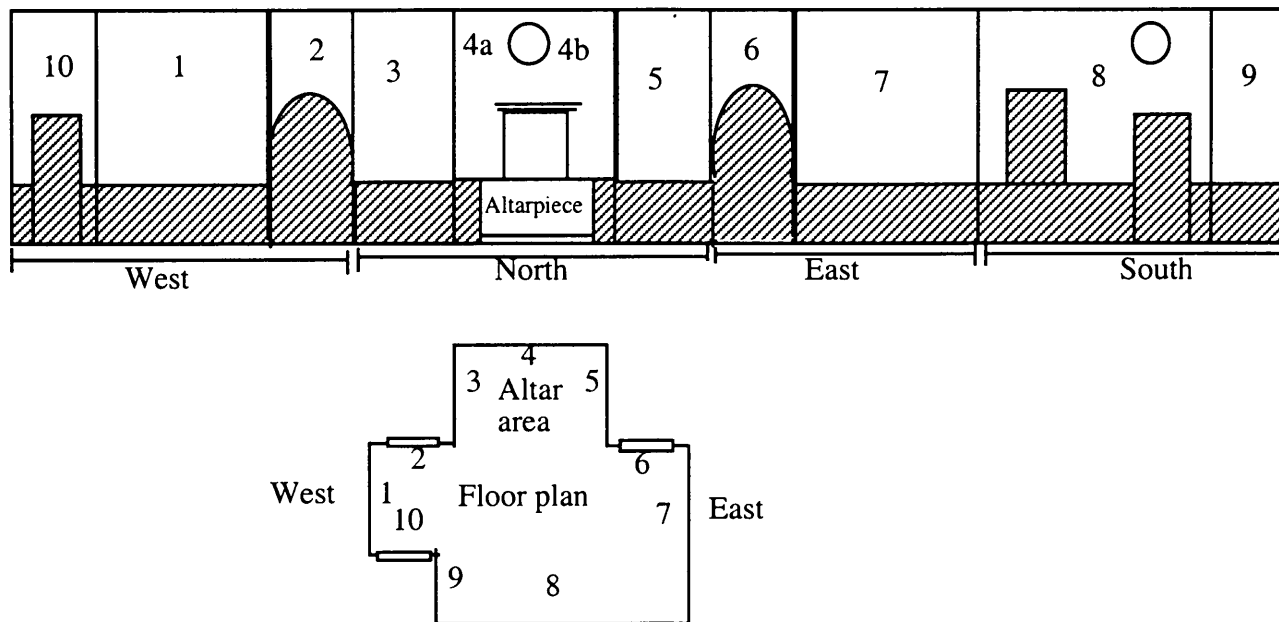

- | | |
|---|---|
| 1. Procession of the Old King
(Magus Melchior) | 7. Procession of the Young King
(Magus Caspar) |
| 2. Adoration of the Shepherds | 8. Procession of the Oriental King
(Magus Balthazar) |
| 3. Angels Worshipping | 9. Continuation of the Procession
of the Young King
(altered by construction of
stairway, c.1688-90) |
| 4a. Eagle of St. John | 10. Jacopo Chiavistelli. Landscape |
| 4b. Angel of St. Matthew | |
| 5. Angels Worshipping | |
| 6. Adoration of the Shepherds | |

Sources: Acidini Luchinat, Christina. *Benozzo Gozzoli*. Florence: Scala, 1994.

Acidini Luchinat, Cristina, ed. *The Chapel of the Magi: Benozzo Gozzoli's Frescoes in the Palazzo Medici-Riccardi Florence*. London and New York: Thames and Hudson, 1994.

Amaducci, Alberto. *La cappella di palazzo medici*. Florence: Arsuna, 1977.

Bargellini, Piero. *The Medici Palace and the Frescoes of Benozzo Gozzoli*. Rome: Lorenzo del Turco, 1965.

Toesca, Elena Berti. *Benozzo Gozzoli: gli affreschi della cappella medicea*. Milan: Amilcare Pizzi, 1958.

**GRUNEWALD, MATTHIAS
and NICOLAS HAGENAU**

Isenheim Altarpiece
Unterlinden Museum, Colmar
c.1512-16

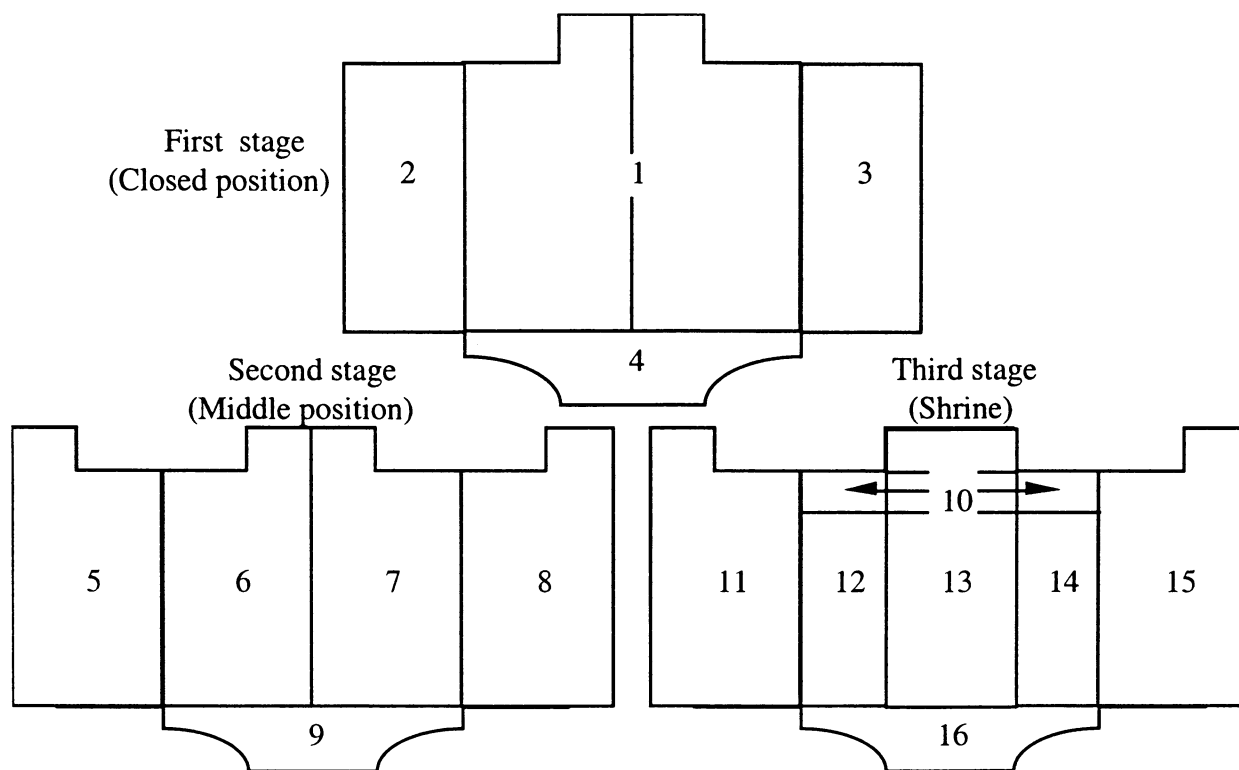

First stage

1. Crucifixion
 2. St. Sebastian
 3. St. Anthony
 4. Lamentation
- Second stage
5. Annunciation
 6. Angelic Concert
 7. Madonna and Child
 8. Resurrection
 9. Lamentation

Third stage

10. Nicolas Hagenau. Framework
11. Meeting of Sts. Anthony and Paul
12. Nicolas Hagenau. St. Augustine
13. Nicolas Hagenau. St. Anthony
14. St. Jerome
15. Temptation of St. Anthony
16. Christ and the Twelve Apostles

Sources: Mellinkoff, Ruth. *The Devil at Isenheim: Reflections of Popular Belief in Grunewald's Altarpiece*. Berkeley: University of California Press, 1988.

Scheja, Georg. *The Isenheim Altarpiece*. New York: Harry N. Abrams, 1969.

St. Lawrence Altarpiece
Cathedral
Linloping, Sweden
1538-42

HEEMSKERCK, MAERTIN VAN

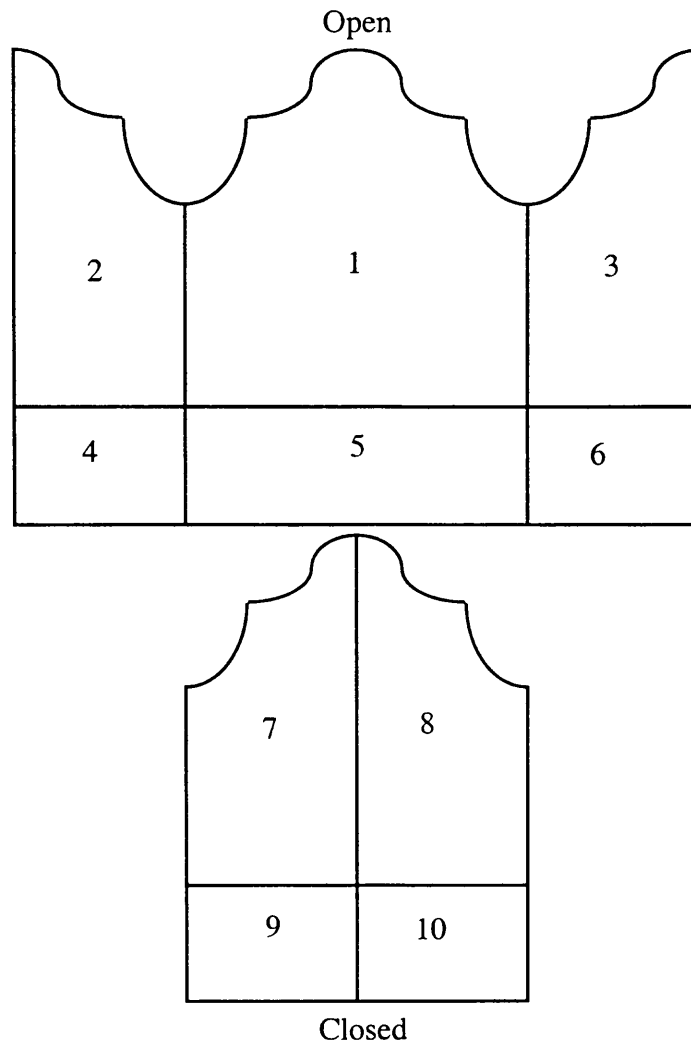

Open

1. Crucifixion
2. Ecce Homo
3. Resurrection
4. Road to Calvary
5. Flagellation
6. Crowning with Thorns

Closed

7. Martyrdom of St. Lawrence
8. St. Lawrence Distributing Alms
9. Adoration of the Shepherds
10. Last Supper

Source: Grosshans, Rainald. *Maerten van Heemskerck: Die Gemalde*. Berlin: Horst Boettcher, 1980.

**LIPPI, FRA FILIPPO
and Fra Diamante di Feo**

**Legends of St. Stephen and St. John the Baptist
Choir Chapel, Cathedral
Prato
1452-54**

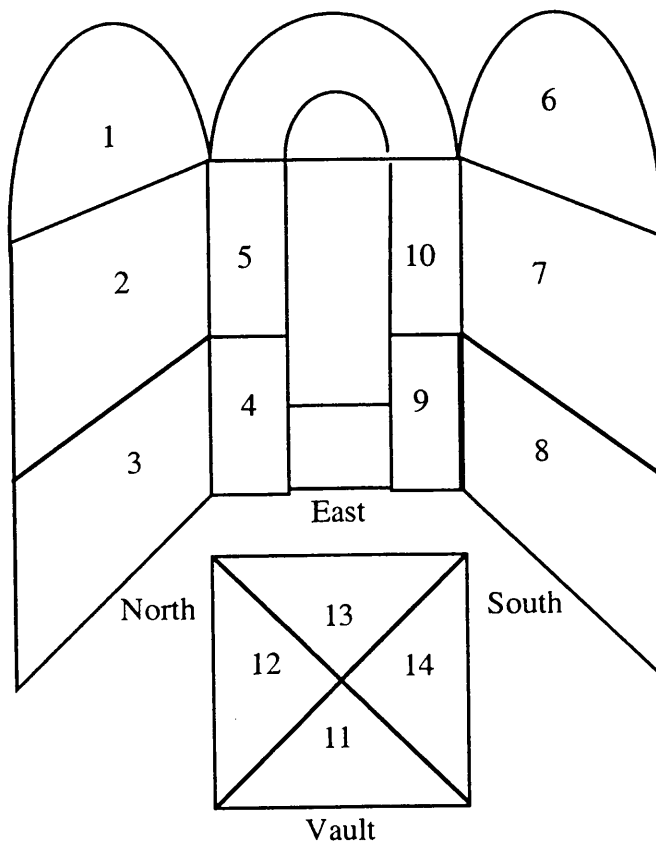

- | | |
|--|--|
| <ol style="list-style-type: none"> 1. Birth of St. Stephen and Boyhood of St. Stephen 2. St. Stephen Consecrated to the Priesthood; St. Stephen Taking Leave of Bishop Julian; St. Stephen Exorcising the Changeling; and St. Stephen Disputing with the Pharisees 3. Funeral of St. Stephen; Martyrdom of St. Stephen; and Saul with the Martyr's Robe 4. Martyrdom of St. Stephen 5. St. John Gualbertus 6. Birth and Naming of St. John the Baptist | <ol style="list-style-type: none"> 7. St. John the Baptist in the Wilderness; St. John's Sermon to the Multitude; St. John Praying in the Wilderness; and St. John Taking Leave of His Parents 8. Beheading of St. John the Baptist; Banquet of Herod; and the Dance of Salome 9. Beheading of St. John the Baptist 10. Alberto of Trapani 11. St. John the Evangelist 12. St. Luke 13. St. Mark 14. St. Matthew |
|--|--|

Sources: Borsook, Eve. *The Mural Painters of Tuscany: From Cimabue to Andrea del Sarto*. 2nd ed. Oxford: Clarendon Press, 1980.

Roettgen, Steffi. *Italian Frescoes: Vol.1, The Early Renaissance 1400-1470*. New York, London and Paris: Abbeville Press, 1996.

Allegory of Good and Bad Government
 Sala della Pace, Palazzo Pubblico, Siena
 1338-39

LORENZETTI, AMBROGIO

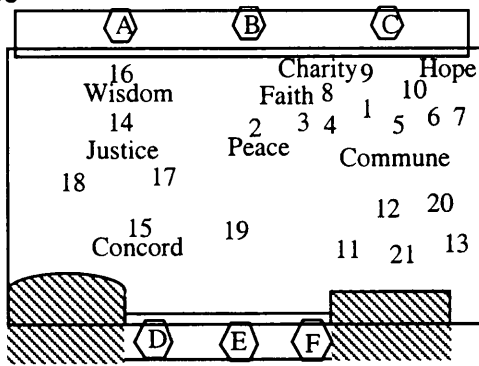

I. Allegory of Good Government

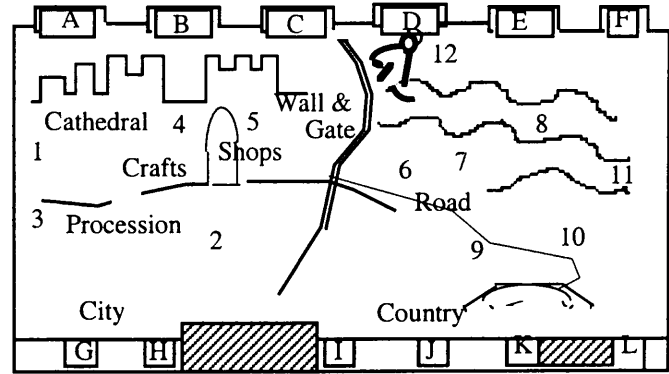

II. Allegory of Good Government in the City and the Country

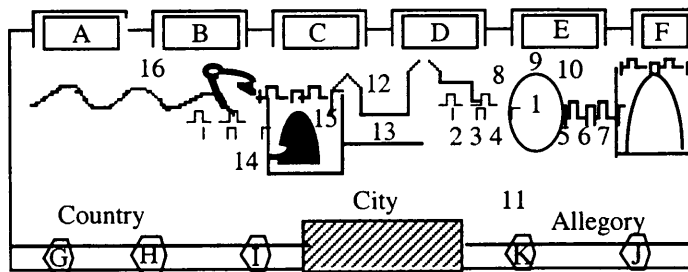

III. Allegory of Bad Government

- E. Spring
- F. Moon
- G. Arithmetic (destroyed)
- H. Geometry
- I. Music
- J. Astrology
- K. Philosophy
- L. Shield of Siena (destroyed)

III. Allegory of Bad Government

1. Tyranny

Civic Vices

- 2. Cruelty
- 3. Treason
- 4. Fraud
- 5. Furor
- 6. Division
- 7. War
- 8. Avarice
- 9. Pride
- 10. Vainglory
- 11. Justice Prisoner

City

- 12. Shops of War Tools
- 13. Robbers
- 14. Soldiers Assaulting a Woman
- 15. Woman Apprehended by a Soldier

Country

- 16. Fear

Medallions

- A. Saturn
- B. Autumn
- C. Jupiter
- D. Shields
- E. Winter
- F. Mars
- G., H., I., J. Destroyed
- K. Nero

I. Allegory of Good Government

- 1. Commune
- Six Civic Virtues**
- 2. Peace
- 3. Fortitude
- 4. Prudence
- 5. Magnanimity
- 6. Temperance
- 7. Justice
- Three Theological Virtues**
- 8. Faith
- 9. Charity
- 10. Hope
- 11. Romulus and Remus
- 12. Soldiers
- 13. Prisoners
- 14. Justice
- 15. Concord
- 16. Wisdom
- 17. Communitive Angel
- 18. Distributive Angel
- 19. Twenty-four Secular Administrators
- 20. Mounted Knights
- 21. Kneeling Knights

Medallions

- A., B., C. Hidden by Cross Beam
- D. Grammar
- E. Dialect
- F. Rhetoric (destroyed)

II. Good Government in the City and Country

City

- 1. Cathedral
- 2. Figures with Animals and Dancers
- 3. Procession
- 4. Crafts
- 5. Shops

Country

- 6. Horsemen Leaving City (Falconer)
- 7. Farm House
- 8. Hills and Lake
- 9. Hunting in a Field
- 10. Plowing with Oxen
- 11. Farmlands and Fieldworkers
- 12. Security

Medallions

- A. Venus
- B. Summer
- C. Crossed Keys
- D. Mercury

Sources: Frugoni, Chiara. *Pietro and Ambrogio Lorenzetti*. Florence: Scala, 1988.

Rowley, George. *Ambrogio Lorenzetti*. 2 vols. Princeton, N.J.: Princeton University Press, 1958.

Starn, Randolph. *Ambrogio Lorenzetti: The Palazzo Pubblico, Siena*. New York: George Braziller, 1994.

LORENZETTI, PIETRO

Carmine Altarpiece
 (formerly San Nicolo, Siena)
 Pinacoteca Nazionale, Siena,
 (other locations listed below)
 completed by 1329

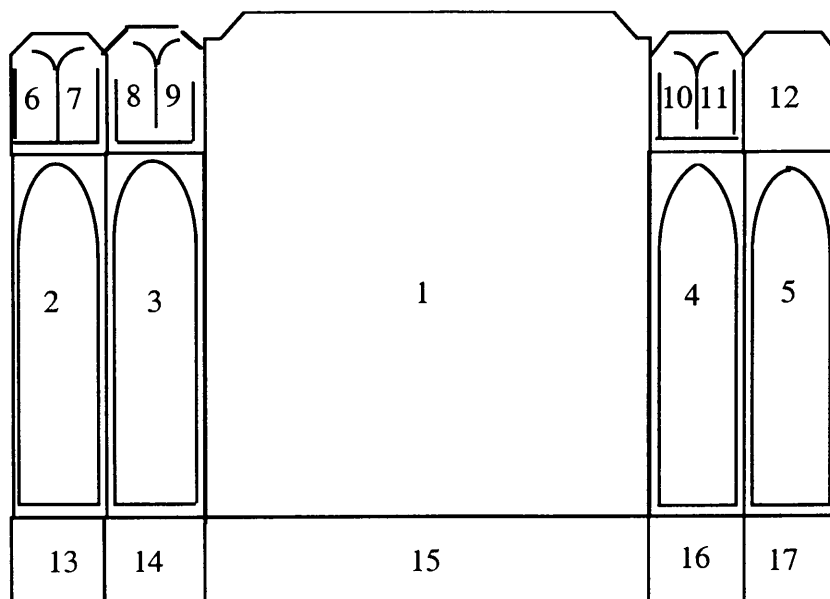

Main panels

- | | |
|---|---|
| 1. Madonna and Child with Angels, St. Nicholas and the Prophet Elijah | 10. St. Andrew (New Haven, CT., Yale University Art Gallery) |
| 2. St. Agnes | 11. St. James Major (New Haven, CT., Yale University Art Gallery) |
| 3. Prophet Elisha (Princeton, N.J., University Art Museum) | 12. Missing |
| 4. St. John the Baptist (Princeton, N.J., University Art Museum) | |
| 5. St. Catherine of Alexandria | |

Cusps:

- 6. St. Thomas
- 7. St. James Minor
- 8. St. Thaddeus (Jude)
- 9. St. Bartholomew

Predella:

- 13. Dream of Sobach
- 14. Elijah's Well
- 15. Handing Over of the Rule
- 16. Approval of the Rule
- 17. Honorius IV Approves the New Habit

Source: Frugoni, Chiara. *Pietro and Ambrogio Lorenzetti*. Florence: Scala, 1988.

Altarpiece of Blessed Humility
 Uffizi, Florence
 Staatliche Museen, Berlin
 1341

LORENZETTI, PIETRO

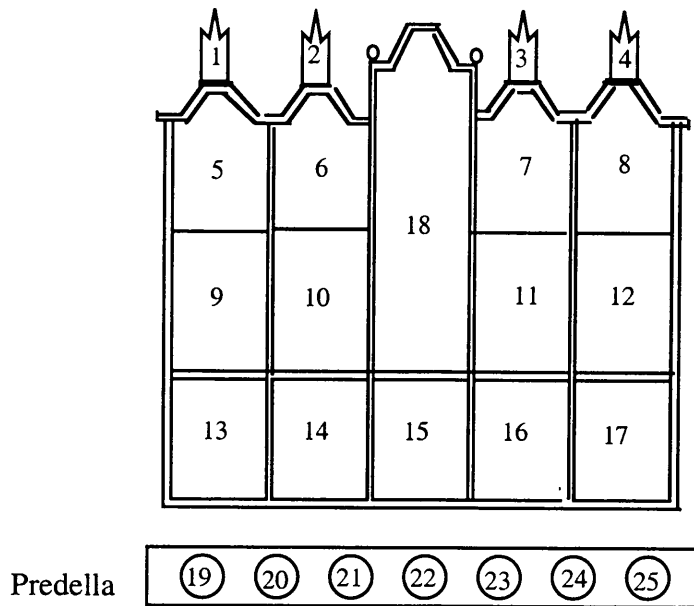

Pinacles:

1. St. Mark
2. St. John
3. St. Matthew (missing)
4. St. Luke

Main Panels:

5. Rosanese Leaves Ugonotto for a holy life
6. Ugonotto Accepts the Religious Vestments
7. Humility Reads Miraculously in Refectory of St. Perpetua
8. Humility Leaves Convent and Crosses the River Lamone
9. A Monk Refuses to Amputate a Bad Foot
10. St. Humility Heals the Foot
11. St. Humility Departs for Faenza

12. St. Humility Resuscitates a Baby
13. St. Humility Carries Bricks to Construct the Convent
14. Inspired by the Holy Spirit, St. Humility Gives a Sermon
15. Healing of a Monk (Berlin, Staatliche Museen)
16. Miracle of the Frost in August (Berlin, Staatliche Museen)
17. Funeral of St. Humility
18. St. Humility and the Story of Her Life

Predella Roundels (modern presentation):

19. St. Benedict
20. St. Paul
21. Virgin
22. Pieta
23. St. John the Evangelist
24. St. Peter
25. St. Giovanni Gualberto

Sources: Frugoni, Chiara. *Pietro and Ambrogio Lorenzetti*. Florence: Scala, 1988.

Marcucci, Luisa. *Gallerie nazionali di Firenze: i dipinti toscani del secolo XIV*. Rome: Istituto poligrafico dello Stato, 1965.

LORENZETTI, PIETRO

Arezzo Polyptych
 Church of Santa Maria, Arezzo
 1320

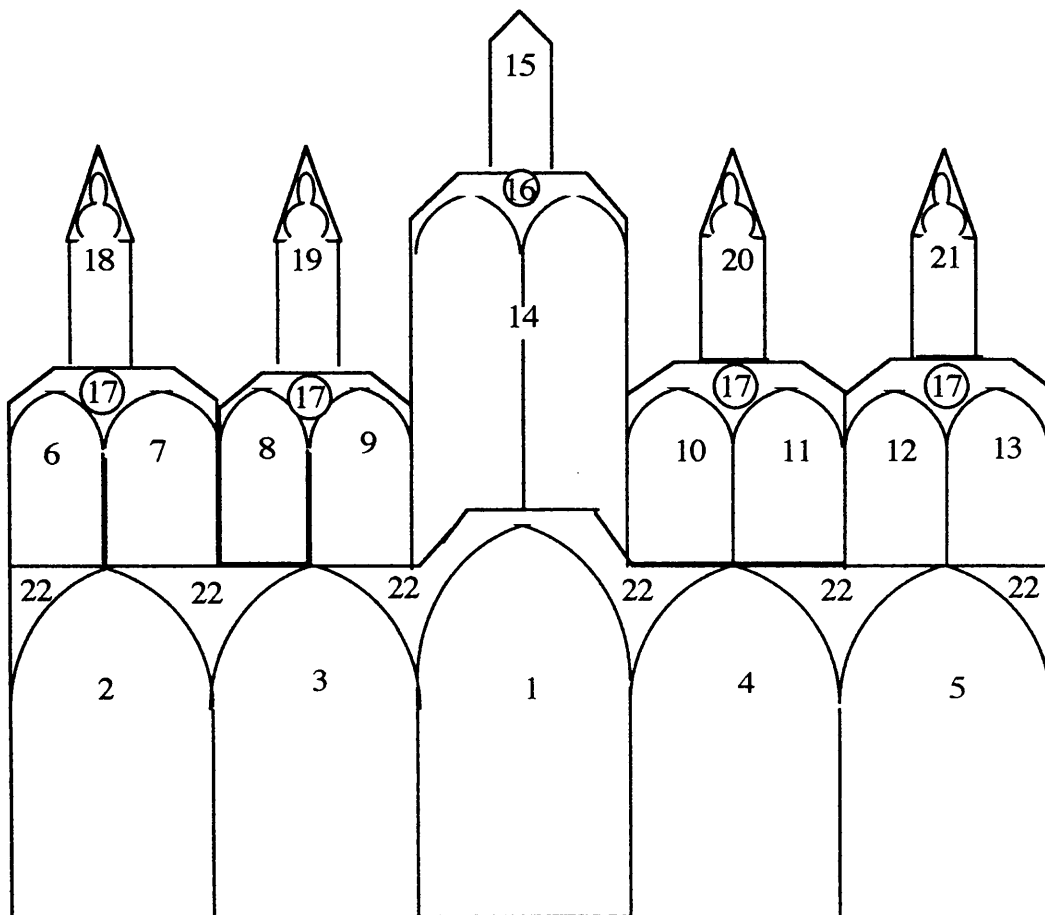

- | | | |
|----------------------------|---------------------|-------------------|
| 1. Madonna and Child | 10. St. James Major | 18. St. Reparata |
| 2. St. Donatus | 11. St. James Minor | 19. St. Catherine |
| 3. St. John the Evangelist | 12. St. Marcellus | 20. St. Ursula |
| 4. St. John the Baptist | 13. St. Augustine | 21. St. Agatha |
| 5. St. Matthew | 14. Annunciation | 22. Angels |
| 6. St. John | 15. Assumption | |
| 7. St. Paul | 16. Prophet Head | |
| 8. St. Vincent | 17. Prophet Head | |
| 9. St. Luke | | |

Sources: DeWald, Ernest T. *Pietro Lorenzetti*. Cambridge: Harvard University Press, 1930.
 Frugoni, Chiara. *Pietro and Ambrogio Lorenzetti*. Florence: Scala, 1988.

Frescoes, Lower Church,
San Francesco
Assisi
c.1325-50

LORENZETTI, PIETRO

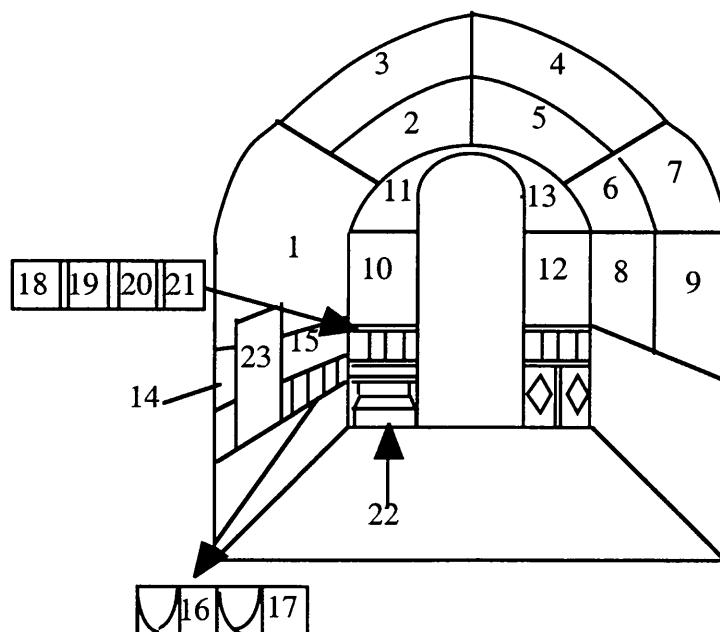

- | | |
|-----------------------------------|--|
| 1. Crucifixion | 13. Resurrection |
| 2. Road to Calvary | 14. St. Victor |
| 3. Flagellation | 15. Madonna and Child with Sts.
Francis and John the Evangelist |
| 4. Last Supper | 16. Crucifixion |
| 5. Entry into Jerusalem | 17. Donor Portrait |
| 6. Washing of the Disciples' Feet | 18. St. Ruffino |
| 7. Betrayal | 19. St. Catherine of Alexandria |
| 8. Suicide of Judas | 20. St. Clare |
| 9. Stigmatization | 21. St. Margaret |
| 10. Descent from the Cross | 22. Trompe L'Oeil Empty Bench |
| 11. Descent into Limbo | 23. Destroyed Section of the Crucifixion |
| 12. Entombment | |

Sources: Bellosi, Luciano. *Pietro Lorenzetti ad Assisi*. Assisi: Edizioni DACA, 1982.
 Borsook, Eve. *The Mural Painters of Tuscany: From Cimabue to Andrea del Sarto*. 2nd ed.
 Oxford: Clarendon Press, 1980.
 Cecchi, Emilio. *Pietro Lorenzetti*. Milan: Fratelli Treves, 1930.
 Frugoni, Chiara. *Pietro and Ambrogio Lorenzetti*. Florence: Scala, 1988.
 Poeschke, Joachim. *Die Kirche San Francesco in Assisi und ihre Wandmalereien*. Trans-
 lated by Russell Stockman. Munich: Hirmer Verlag, 1985.

LORENZO MONACO

Coronation of the Virgin
 Altarpiece
 Uffizzi, Florence
 1413

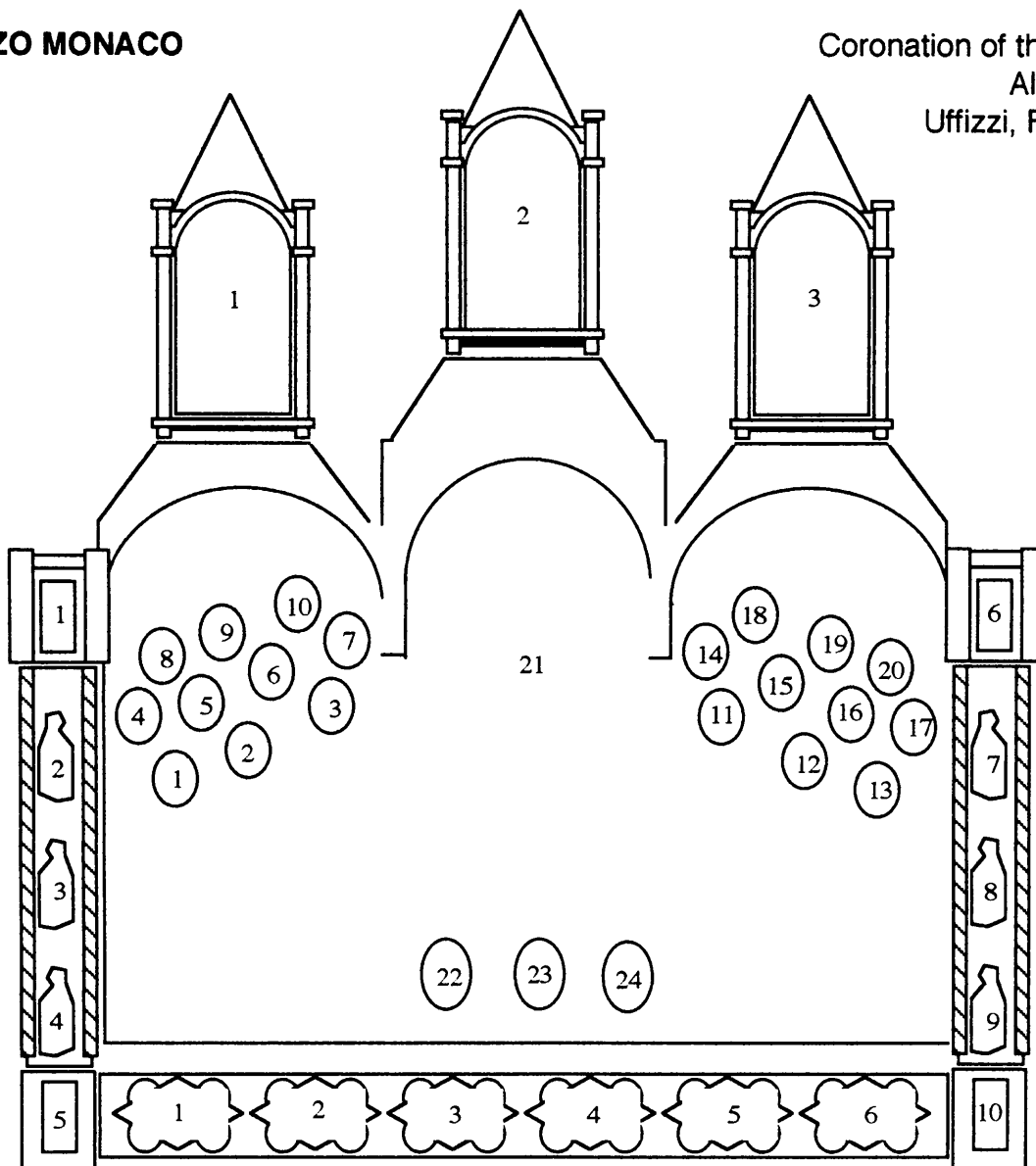

Predella

1. Death of St. Benedict
2. St. Benedict in the Sacro Speco and a Young Monk Tempted from Prayer
3. Nativity
4. Adoration of the Magi
5. St. Maurus Rescuing St. Placidus and the Visit of St. Benedict to St. Scholastica
6. St. Benedict Raises a Young Monk

Pinnacles

1. Angel of the Annunciation
2. Christ Blessing and Angels
3. Virgin of the Annunciation

Pilasters

1. Prophet
2. Noah
3. Abraham
4. David
5. Prophet
6. Prophet
7. Moses
8. Prophet
9. Daniel
10. Prophet

Main Panel

1. St. Benedict
2. St. Peter
3. St. John the Baptist
4. St. Stephen
5. St. Paul
6. St. James Major
7. St. Matthew
8. Crowned Saint
9. St. Anthony Abbot
10. Bishop Saint
11. St. John the Evangelist
12. St. Andrew

13. St. Romauld
14. St. Lawrence
15. St. Bartholomew
16. St. Zenobius
17. St. Giovanni Gualberto
18. Turbaned Saint
19. Monk Saint
20. Warrior Saint
21. Coronation of the Virgin
- 22.-24. Angels with Censers

Source: Eisenberg, Marvin. *Lorenzo Monaco*. Princeton, New Jersey: Princeton University Press, 1989.

Recanati Polyptych
Pinacoteca, Recanati and
Kunsthistorisches Museum, Vienna
Signed and dated 1508
(dismantled in the 19c and
reassembled in 1914)

LOTTO, LORENZO

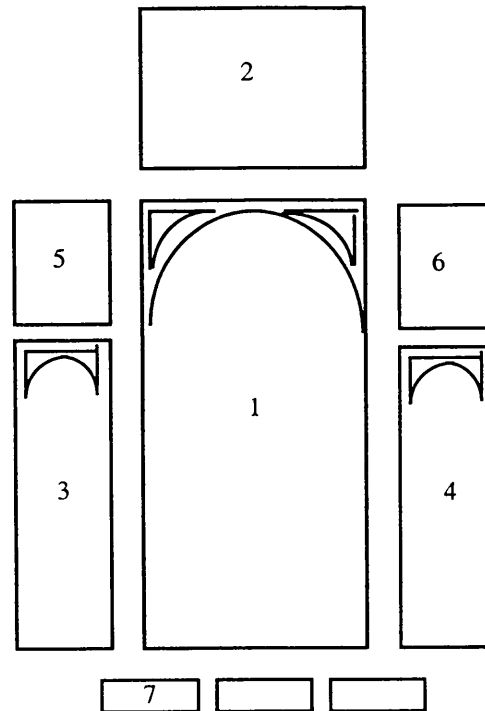

- | | |
|---|---|
| 1. Madonna Enthroned with Saints and Musical Angels | 5. Saints Catherine of Alexandria and Vincent Ferrer |
| 2. Pieta | 6. Saints Catherine of Siena and Sigismund |
| 3. Saints Thomas Aquinas and Flavian | 7. A Dominican Saint Preaching (Vienna, Kunsthistorisches Museum) |
| 4. Saints Peter Martyr and Vitus | |

Source: Bianconi, Piero. *All the Paintings of Lorenzo Lotto*. 2 vols. Translated by Paul Colacicchi. New York: Hawthorn Books, Inc., 1963.

LOTTO, LORENZO

St. Stephen Altarpiece
Santo Stefano al Fortino
other locations listed below
1513-16
(disassembled in 1749)

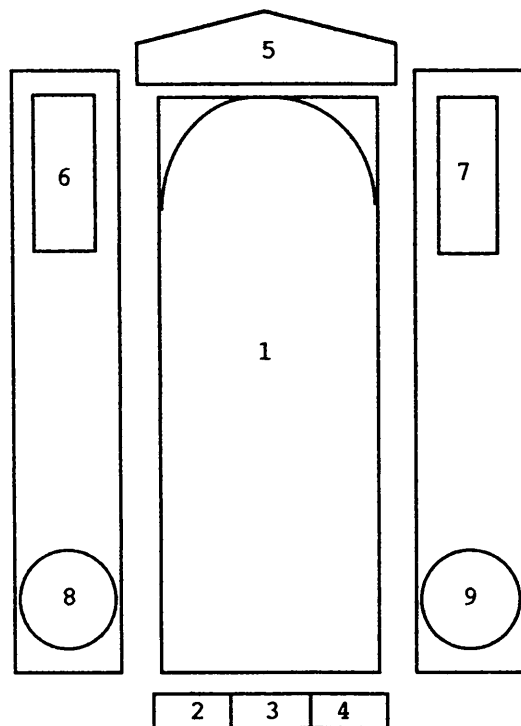

1. Madonna Enthroned with Saints (Bergamo, Church of San Bartolomeo)
2. Martyrdom of St. Stephen (Bergamo, Galleria dell' Accademia Carrara)
3. Deposition of Christ (Bergamo, Galleria dell' Accademia Carrara)
4. Miracle of St. Domenic (not finished by Lotto; Bergamo, Galleria dell' Accademia Carrara)
5. Angel with Globe and Scepter (Budapest, Museum of Fine Arts)
6. St. Peter Martyr (Florence, R. Longhi Collection)
7. A Dominican Saint (Florence, R. Longhi Collection)
8. Martyrdom of St. Alexander (Raleigh, North Carolina Museum of Art)
9. Dead Christ Supported by Angels (Raleigh, North Carolina Museum of Art)

Source: Bianconi, Piero. *All the Paintings of Lorenzo Lotto*. 2 vols. Translated by Paul Colacicchi. New York: Hawthorn Books, Inc., 1963.

Ovetari Chapel Frescoes
Church of the Ermetari
Padua
c.1448-51
(destroyed 1944)

MANTEGNA, ANDREA

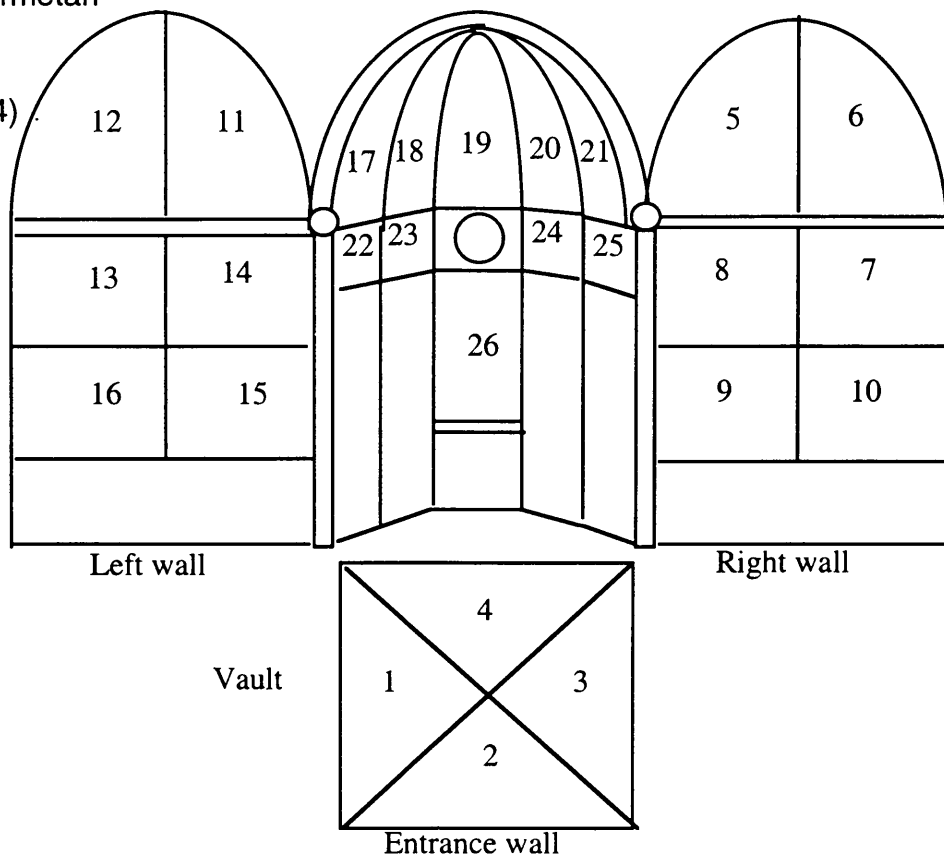

Vault

1. Giovanni d'Alemagna and Antonio Vivarini. St. Mathew
2. Giovanni d'Alemagna and Antonio Vivarini. St. Mark
3. Giovanni d'Alemagna and Antonio Vivarini. St. Luke
4. Giovanni d'Alemagna and Antonio Vivarini. St. John

Right wall: St. Christopher

5. Girolamo di Camerino?. St. Christopher Before the King of Canaan
6. Ansuino da Forli?. St. Christopher Encounters the Devil
7. Ansuino da Forli. Arrest of St. Christopher
8. Bono da Ferrara. St. Christopher Carrying the Christ Child
9. Attempted Martyrdom of St. Christopher
10. St. Christopher Beheaded

Left wall: St. James

11. St. James Disputing with the Demons
12. Calling of Sts. James and John
13. St. James Baptizing Hermogenes
14. St. James before Herod
15. St. James Led to Execution
16. Execution of St. James

Apse

17. Niccolo Pizzolo. St. James the Greater
18. St. Peter
19. Niccolo Pizzolo. God the Father
20. St. Paul
21. St. Christopher
22. Niccolo Pizzolo. St. Jerome
23. Niccolo Pizzolo. St. Augustine (?)
24. Niccolo Pizzolo. St. Gregory the Great
25. Niccolo Pizzolo. St. Ambrose
26. Assumption

Sources: Christiansen, Keith. *Andrea Mantegna, Padua and Mantua*. New York: Braziller, 1994.
Fiocco, Giuseppe. *The Frescoes of Mantegna in the Eremitani Church, Padua*.
2nd ed. Oxford: Phaidon Press, 1978.

MANTEGNA, ANDREA

Polyptych of St. Luke (frame lost)
Brera, Milan
1453-54

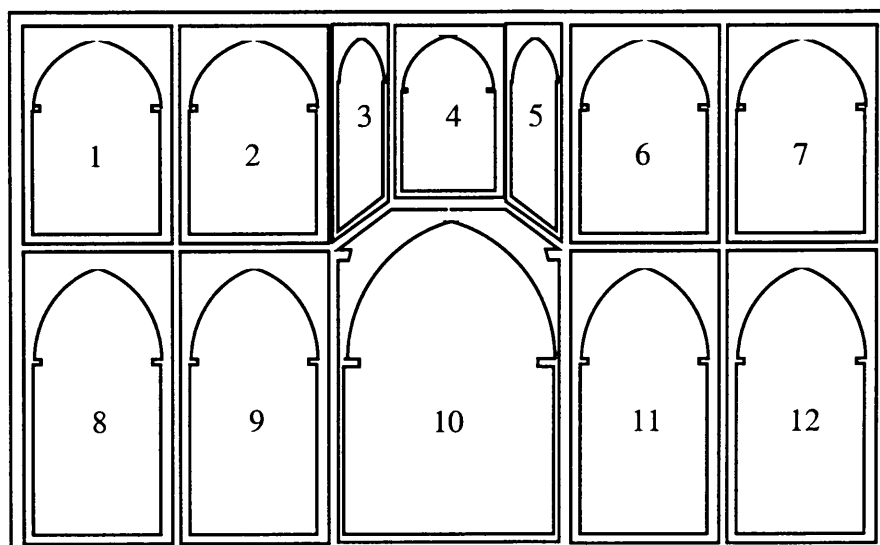

1. St. Daniel of Padua
2. St. Jerome
3. Mater Dolorosa
4. Christ in Pieta
5. St. John the Evangelist
6. St. Maximus, Bishop of Padua (or St. Augustine)
7. St. Julian (or St. Sebastian)
8. St. Felicita (Scholastica)
9. St. Prosdecimus
10. St. Luke
11. St. Benedict
12. St. Justina of Padua

Sources: Bandera Bistoletti, Sandrina. *Il polittico di San Luca di Andrea Mantegna (1453-1454): in occasione del suo restauro*. Florence: Cantini, 1989.

Fiocco, Giuseppe. *L'arte di Andrea Mantegna*. Venice: Neeri Pozza Editore, 1959.

Garavaglia, Niny. *L'opera completa del Mantegna*. Milan: Rizzoli, 1967.

Altarpiece of St. Louis of Toulouse
Museo e Gallerie Nazionale di
Capodimonte
Naples
14c

MARTINI, SIMONE

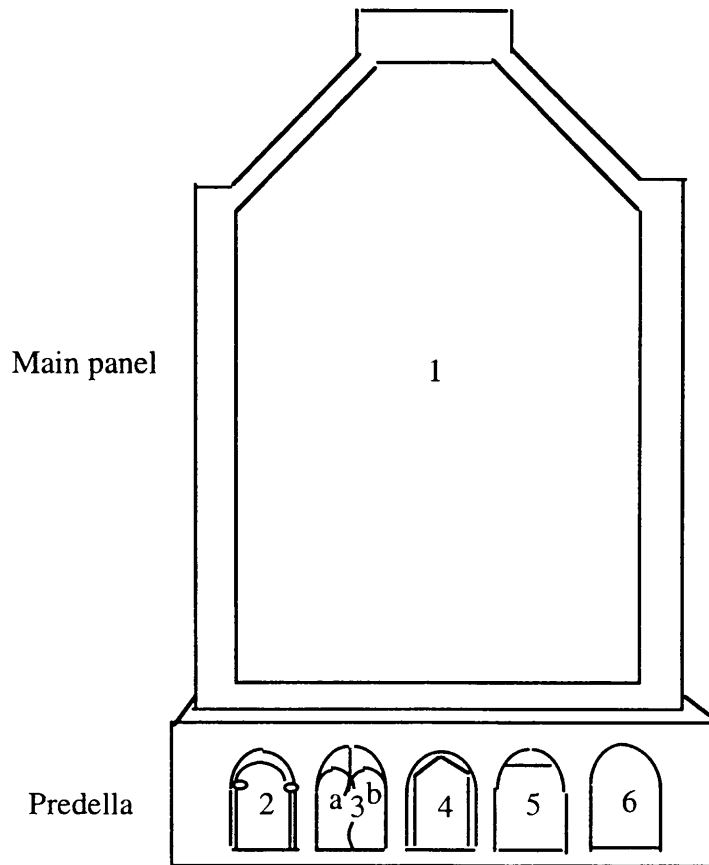

1. St. Louis of Anjou, Bishop of Toulouse, Crowns His Brother, King Robert II
2. St. Louis, before Pope Boniface VIII and Two Bishops, Agrees to Accept the Bishopric of Toulouse
- 3a. St. Louis Received into the Franciscan Order
- 3b. St. Louis is Consecrated Bishop of Toulouse
4. St. Louis and Guests at a Banquet
5. Funeral of St. Louis at the Church of the Franciscans, Marseilles
6. A Posthumous Miracle of St. Louis

Source: Martindale, Andrew. *Simone Martini*. Oxford: Phaidon, 1988.

MARTINI, SIMONE

Lower Church, Chapel of St. Martin
 San Francesco, Assisi
 Probably 1312-17?

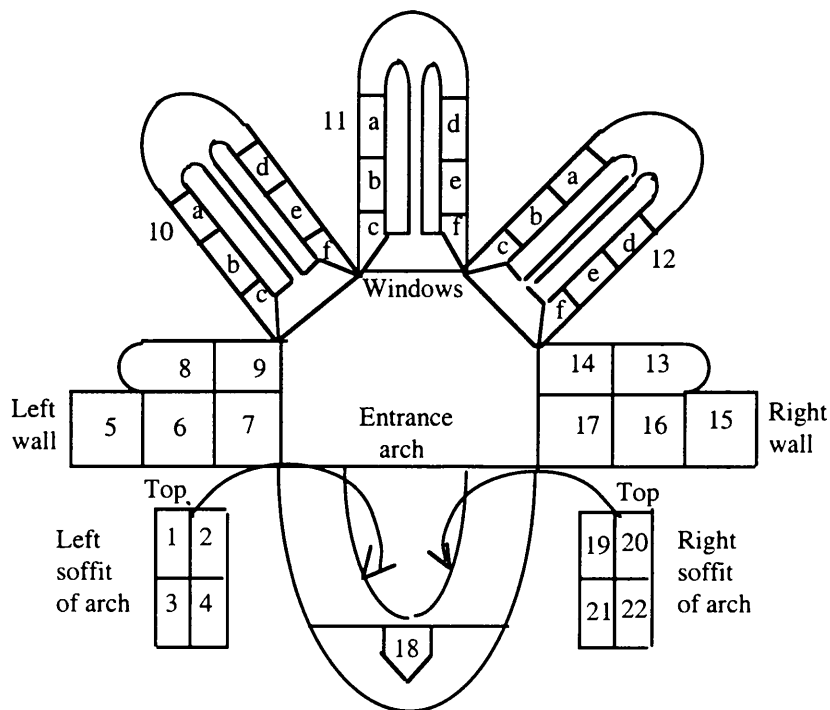

Entrance arch: left soffits

1. St. Louis of France
2. St. Louis of Toulouse
3. St. Clare
4. St. Elizabeth of Hungary

Left wall:

5. Funeral of St. Martin
6. St. Martin Resuscitates a Child
7. St. Martin Divides His Cloak
8. Meditation of St. Ambrose
9. Dream of St. Martin

Windows:

- 10 a-f. Young and Warrior Saints (Young Nobles or Warriors, among Them St. George and Maur)
- 11 a-f. Episcopal Saints (Dedicated to Bishops, One of Whom is a Pope)

- 12 a-f. Right window facings: Monastic and Eremetic Saints (Holy Men and Hermits)

Right wall:

13. Mass of St. Martin
14. Knighting of St. Martin
15. Death of St. Martin
16. Miracle of the Fire
17. St. Martin's Renounces the Sword

Entrance arch: above chapel interior

18. Gentile Partino da Montefiore Kneels before St. Martin

Entrance arch: right soffits

19. St. Anthony of Padua
20. St. Francis of Assisi
21. St. Mary Magdalene
22. St. Catherine of Alexandria

Sources: Martindale, Andrew. *Simone Martini: Oxford: Phaidon, 1988.*

Poeschke, Joachim. *Die Kirche San Francesco in Assisi und ihre Wandmalereien.*

Translated by Russell Stockman. Munich: Hirmer, 1985.

White, John. *Art and Architecture in Italy: 1250-1400.* 1st ed. Harmondsworth, Middlesex: Penguin Books, 1st ed. 1966.

Maesta, Sala del Mappamondo
Palazzo Pubblico
Siena
c.1315-16

MARTINI, SIMONE

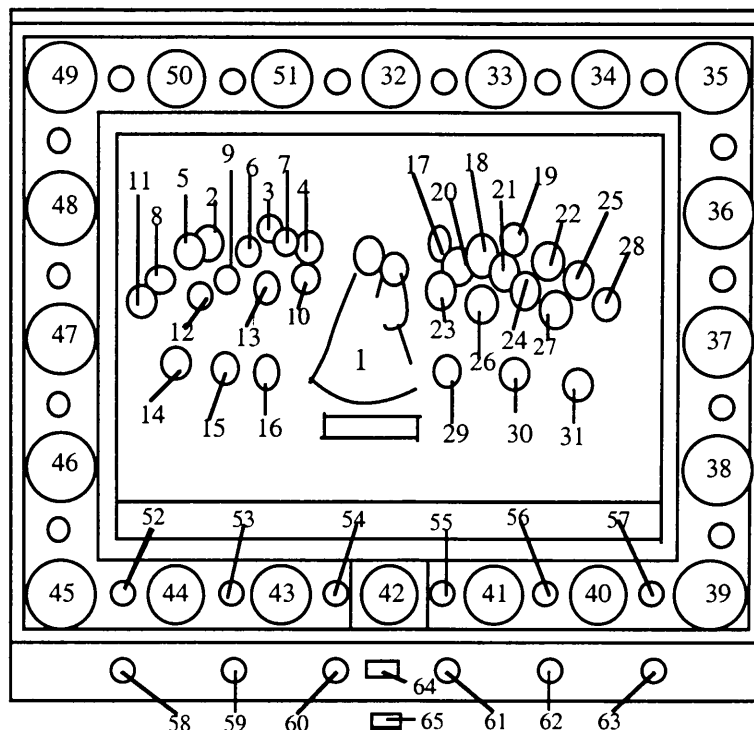

Central Section:

1. Virgin and Child
- 2 - 3. Apostles
(Sts. Philip and Thomas?)
4. Angel
5. Apostle
6. Apostle
7. Apostle
8. Angel
9. St. Mary Magdalene
10. St. Ursula
11. St. Paul
12. St. Michael (probably)
13. St. John the Evangelist
14. St. Ansanus
15. St. Savinus
16. Angel with Bowl of Flowers
17. Angel
18. Apostle
19. Apostle
20. Apostle (St. Andrew?)
21. Apostle
22. Apostle

23. St. Catherine
 24. St. Agnes
 25. Angel
 26. St. John the Baptist
 27. St. Gabriel (or St. Michael)
 28. St. Peter
 29. Angel with Bowl of Flowers
 30. St. Crescentius
 31. St. Victor
- Border:
32. God the Father, Blessing
 33. David
 34. Jacob
 35. St. Mark with Lion
 36. Isaiah
 37. Prophet
 38. Malachi
 39. St. Luke with Ox
 40. St. Ambrose
 41. St. Augustine
 42. The Two Laws or Dispensations
 43. St. Gregory
 44. St. Jerome

45. St. Matthew with Angel
46. Abraham
47. Prophet
48. Daniel
49. St. John with Eagle
50. Isaac
51. Moses
52. Roundel, Grisaille Figure of She-wolf with Romulus and Remus
53. Roundel, White Lion on Red Ground
54. Coin of Siena with Cross
55. Coin of Siena
56. Red Blur
57. Roundel with the Balzana
58. Fictive Plaque of Verde Antico?
59. Fictive Plaque of Porphyry
60. Communal Seal with Virgin and Child with Angels
61. Seal of the Capitano del Popolo
62. Fictive Plaque of Porphyry
63. Fictive Plaque of Porphyry
64. Dating Inscription
65. Dating Inscription

Source: Martindale, Andrew. *Simone Martini*. Oxford: Phaidon, 1988.

**MASACCIO
MASOLINO
FILIPPO LIPPI**

Frescoes, Brancacci
Chapel
Santa Maria del Carmine
Florence, c.1425-85

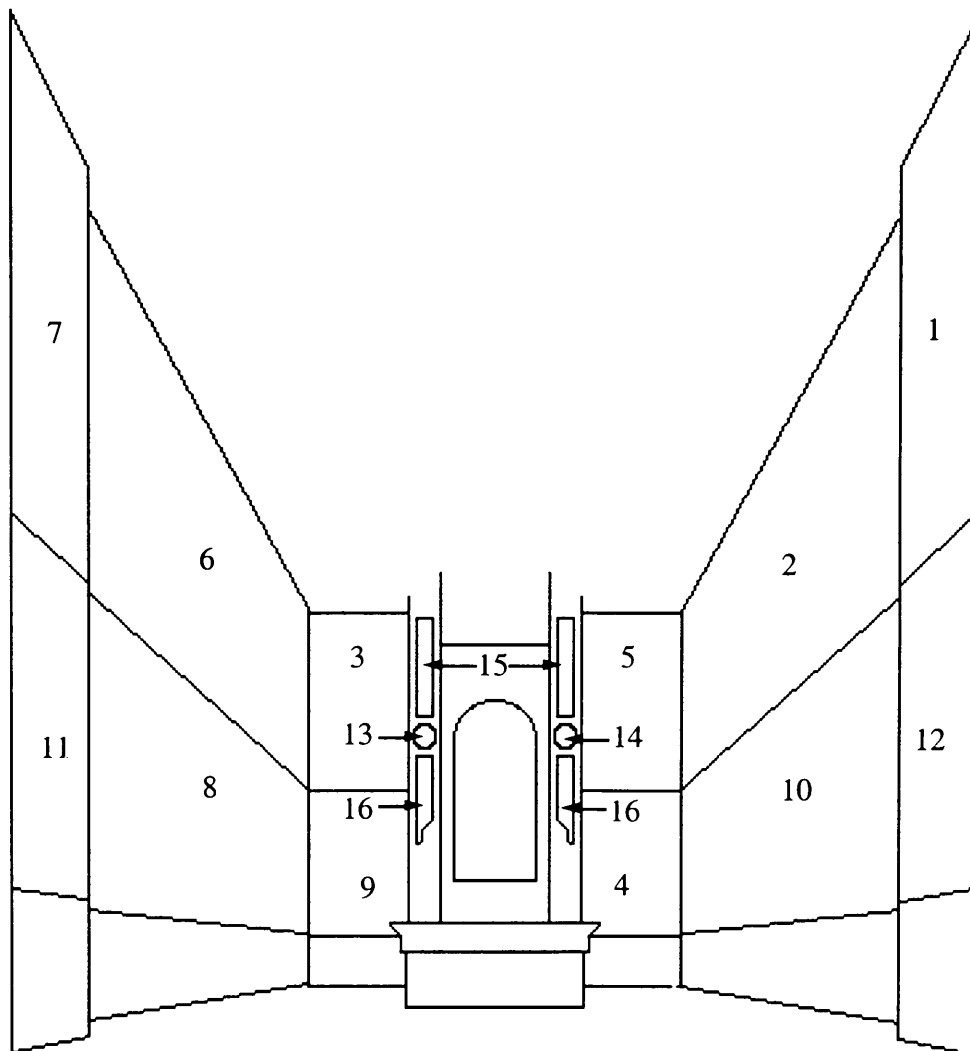

- | | |
|--|---|
| 1. Masolino. Temptation in the Wilderness | 9. Masaccio. St. Peter Healing the Sick with His Shadow |
| 2. Masaccio. Healing of the Lame Man and Resurrection of Tabitha | 10. Lippi. Crucifixion of St. Peter and the Dispute before Nero |
| 3. Masolino. St. Peter Preaching | 11. Lippi. St. Paul Visiting St. Peter in Prison |
| 4. Masaccio. Distribution of Alms | 12. Lippi. St. Peter Released from Prison |
| 5. Masaccio and Masolino. St. Peter Baptising | 13. Masolino. Female Head |
| 6. Masaccio and Masolino?. Tribute Money | 14. Masolino. Male Head |
| 7. Masaccio. Expulsion | 15. Masolino. Floral Motifs above heads |
| 8. Masaccio and Lippi. Resurrection of the Son of Theophilus and St. Peter Enthroned | 16. Masolino. Floral Motifs below heads |

Sources: Busignani, Alberto and Raffaello Bencini. *Le chiese di Firenze. Vol.1. Quartiere di Santo Spirito*. Florence: Sansoni, 1974.

Casazza, Ornella. *Masaccio and the Brancacci Chapel*. Florence: Scala, 1990.

Joannides, Paul. *Masaccio and Masolino: A Complete Catalog*. London: Phaidon Press, 1993.

Pisa Altarpiece
 (reconstruction after Gardner von Teuffel)
 Santa Maria del Carmine, Pisa
 Staatliche Museen, Berlin, and
 other locations listed below
 1426

MASACCIO

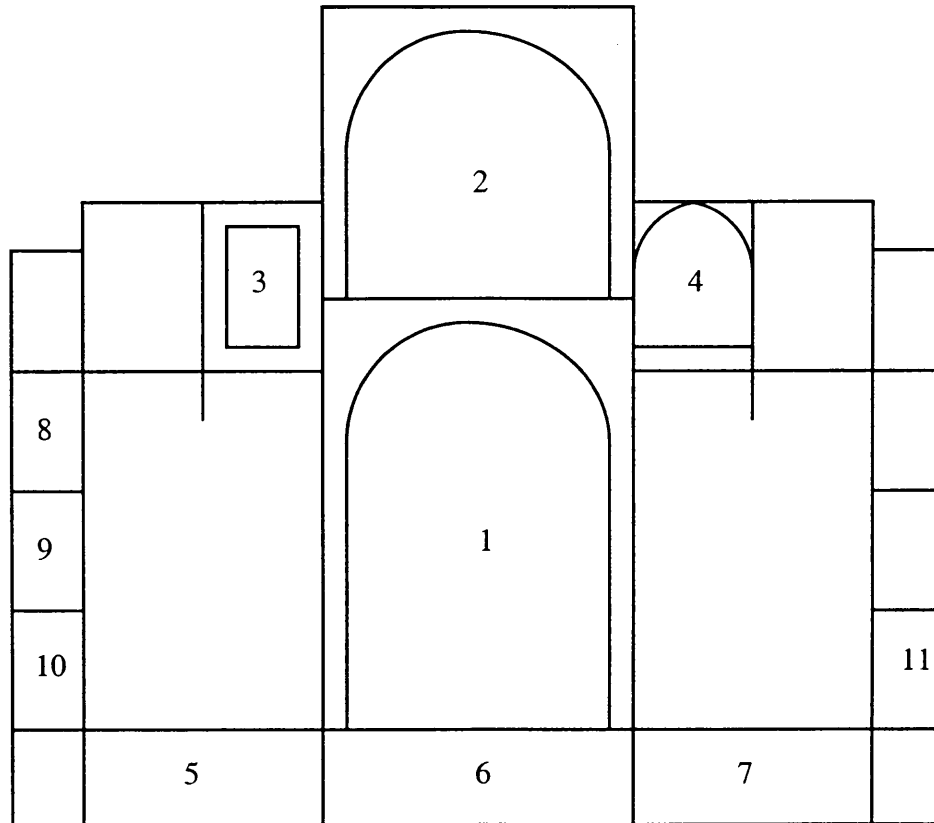

- | | |
|--|---|
| 1. Virgin and Child with Four Angels (London, National Gallery) | 6. Adoration of the Magi |
| 2. Crucifixion (Naples, Museo e Gallerie Nazionali di Capodimonte) | 7. Crucifixion of St. Peter and the Beheading of St. John the Baptist |
| 3. St. Paul (Pisa, Museo Nazionale di S. Matteo) | 8. St. Augustine |
| 4. St. Andrew (Malibu, J. Paul Getty Museum) | 9. St. Jerome |
| 5. St. Julian Killing His Parents and The Charity of St. Nicholas | 10. Carmelite Saint (Albert the Patriarch?) |
| | 11. Carmelite Saint (Elias the Prophet?) |

Sources: Davies, Martin. *The Early Italian Schools: Before 1400*. Rev. ed. by Dillon Gordon. London: National Gallery Publications, 1988.
 Gardner Von Teuffel, Christa. "Masaccio and the Pisa Altarpiece: A New Approach." *Jahrbuch der Berliner Museen*. 19 (1977): 23-68.
 Joannides, Paul. *Masaccio and Masolino: A Complete Catalogue*. London: Phaidon Press, 1993.

MASO DI BANCO

Life of St. Sylvester
 St. Sylvester Chapel
 (Bardi di Yermio Chapel)
 Santa Croce, Florence
 late 1330s

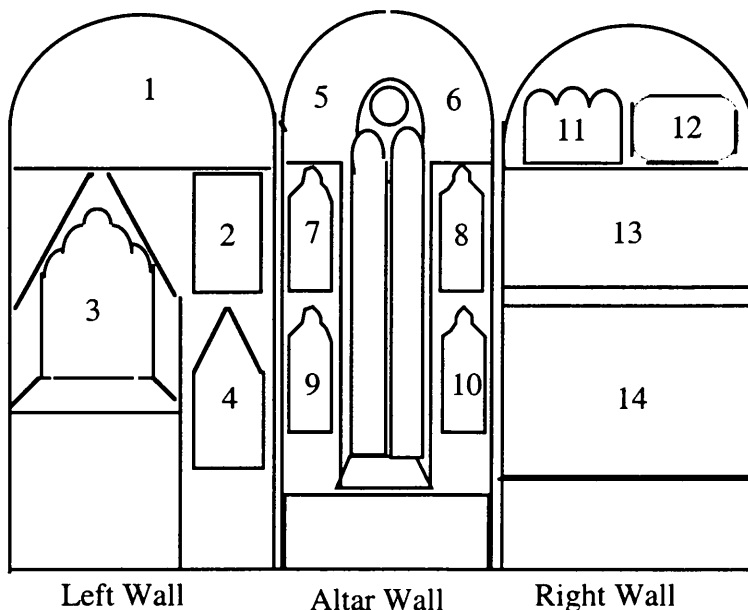

1. Constantine's Announcement of His Decision to Reject to Bathe in the Blood of the Innocent Infants
2. Dream of Constantine
3. Resurrection and Judgement of a Member of the Bardi di Vernio Family
4. Entombment (subsidiary decoration, including Prophets and Man of Sorrows by workshop of Taddeo Gaddi)
5. Destroyed Scene
6. St. Sylvester's Journey to Rome
7. Unidentified Bishop Saint
8. St. Romulus
9. Unidentified Bishop Saint
10. St. Zenobius
11. Constantine's Recognition of the Portraits of Sts. Peter and Paul
12. Baptism of Constantine by St. Sylvester
13. Resurrection by St. Sylvester of a Bull Killed by Pagan Magic
14. Sealing of the Dragon's Mouth and Resurrection of Two Pagan Priests by St. Sylvester

Sources: Wilkins, David G. *Maso di Banco: A Florentine Artist of the Early Trecento*. New York: Garland, 1985.

St. Francis and Scenes
from His Legend,
Bardi Chapel, Santa Croce
Florence
1260s

**MASTER OF THE
BARDI ALTARPIECE**

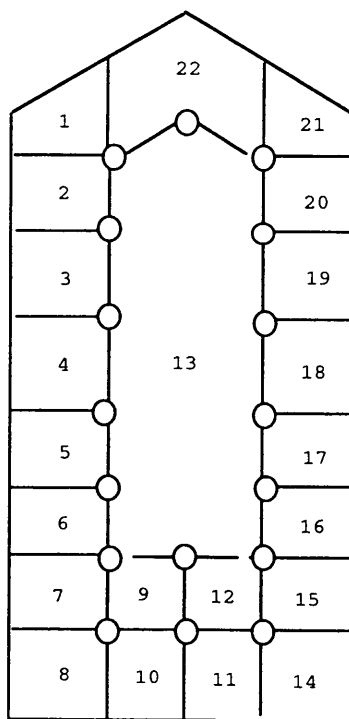

- | | |
|---|---|
| 1. St. Francis Released from His Chains by His Mother While His Father Protests | 13. St. Francis |
| 2. St. Francis Repudiating His Father | 14. Apparition at Arles |
| 3. St. Francis Draws the New Habit | 15. St. Francis Bathes and Cleans the Wounds of a Group of Lepers |
| 4. St. Francis at the Portuncula Hearing the Gospel Injunction to Poverty | 16. Death of St. Francis |
| 5. Confirmation of the Rule | 17. St. Francis Cures a Girl with a Bent Neck; a Possessed Woman; and a Cripple from Foglino |
| 6. Institution of the Crib at Greccio | 18. Canonization of St. Francis |
| 7. St. Francis Preaching to the Birds | 19. St. Francis Calms a Storm Preventing a Shipwreck off the Coast of Ancona |
| 8. Trial by Fire | 20. Ten Penitent Mariners Repeat Their Vows at St. Francis's Tomb |
| 9. St. Francis Rescues a Lamb | 21. Cure of the Cripple from Narni |
| 10. St. Francis Exchanges a Cloak for a Sheep on Its Way to Slaughter | 22. Two Angels Holding a Scroll That Reads, "Listen to This Man Who Bears the Teaching of Life" |
| 11. St. Francis Confessing His Gluttony at Having Eaten Meat | |
| 12. Stigmatization | |

Source: Moleta, Vincent. *From St. Francis to Giotto: The Influence of St. Francis on Early Italian Art and Literature*. Chicago: Franciscan Herald Press, 1983.

MEMLING, HANS

Altarpiece of the Adoration of the Magi
Memlingmuseum, St. Janshospitaal, Bruges
1479

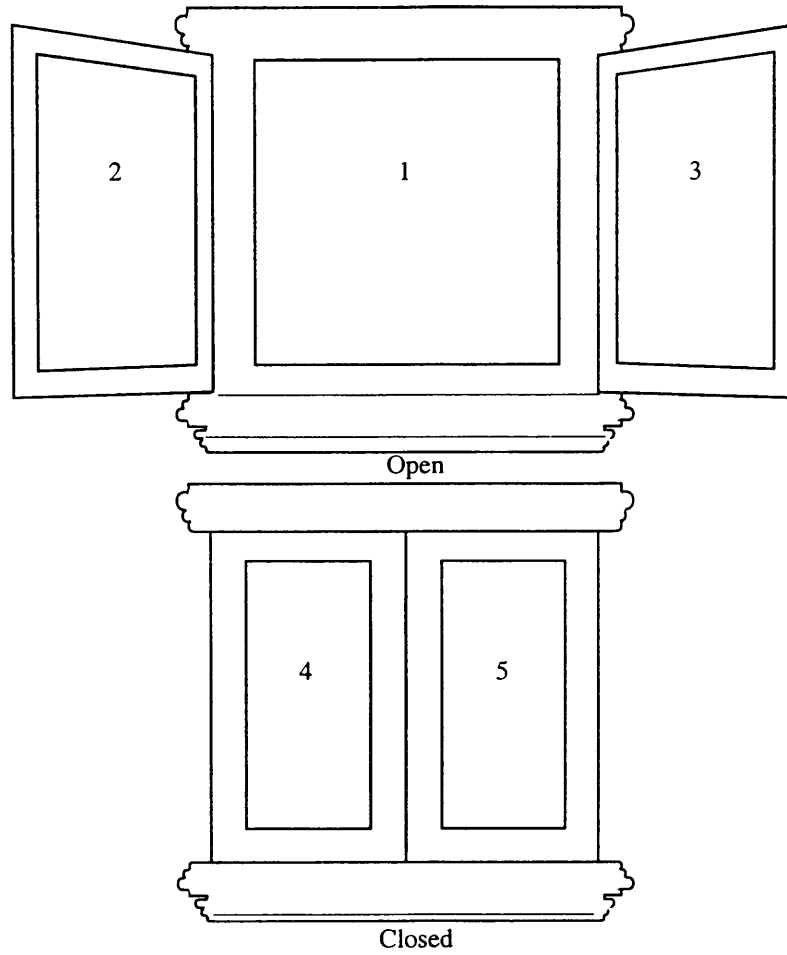

Open:

1. Adoration of the Magi
2. Nativity
3. Presentation in the Temple

Closed:

4. St. John the Baptist
5. St. Veronica

Source: Faggin, George T. *L'opera completa di Memling*. Milan: Rizzoli, 1969.

Altarpiece of the Adoration of the Magi
Prado, Madrid
c.1470

MEMLING, HANS

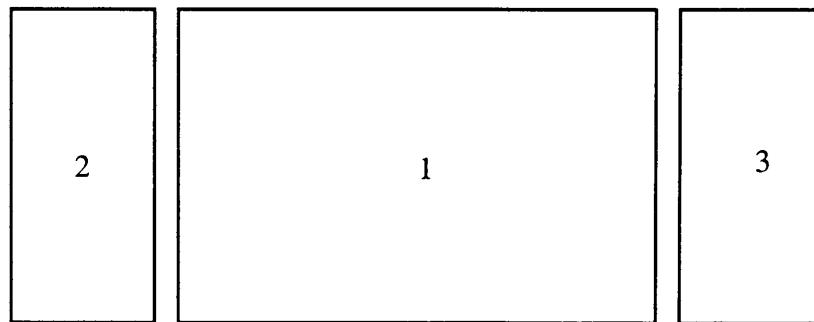

1. Adoration of the Magi
2. Nativity
3. Presentation in the Temple

Source: Faggin, George T. *L'opera completa di Memling*. Milan: Rizzoli, 1969.

MEMLING, HANS

Altarpiece of the Crucifixion
St. Annen-Museum
Lubeck
1491

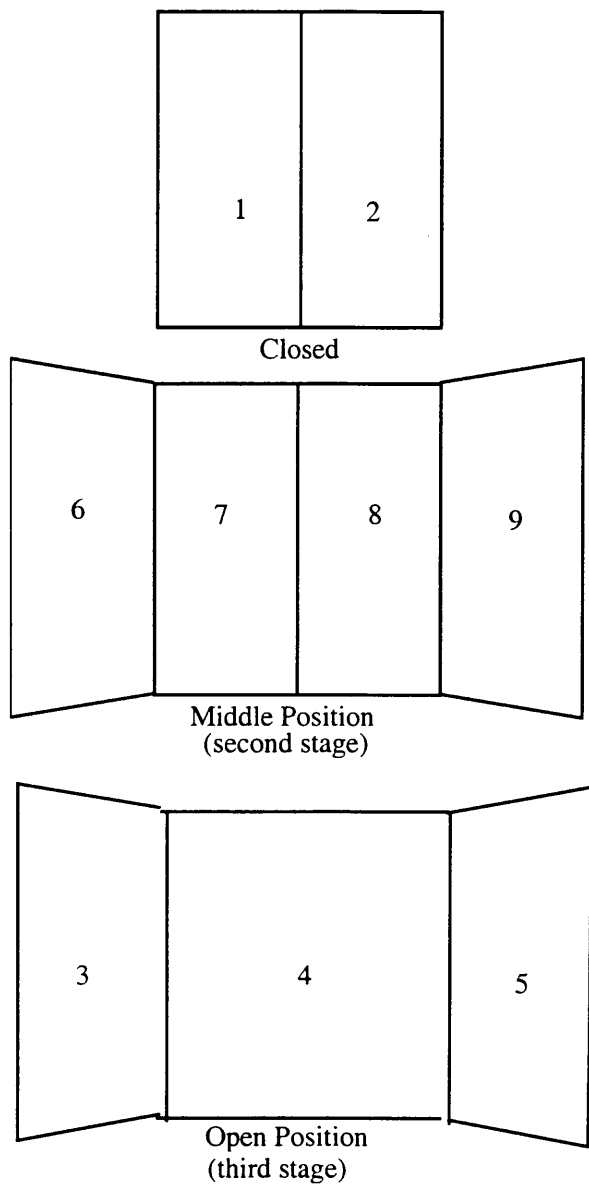

Closed

- 1. Angel of the Annunciation
- 2. Virgin of the Annunciation

Middle Position (Second Stage)

- 6. St. Blaise
- 7. St. John the Baptist
- 8. St. Jerome and the Lion
- 9. St. Giles

Open Position (Third Stage)

- 3. Road to Calvary
- 4. Crucifixion
- 5. Resurrection

Source: Faggin, George T. *L'opera completa di Memling*. Milan: Rizzoli, 1969.

Altarpiece of the Two St. Johns
Memlingmuseum, St. Janshospitaal, Bruges
1479

MEMLING, HANS

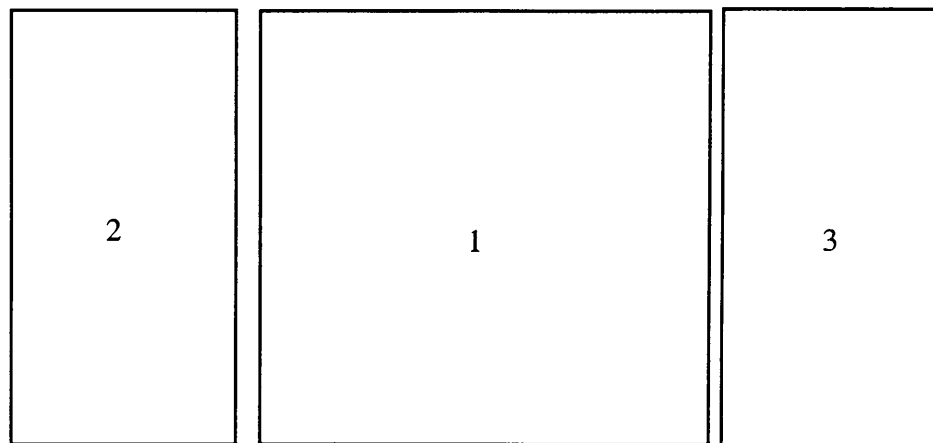

Open

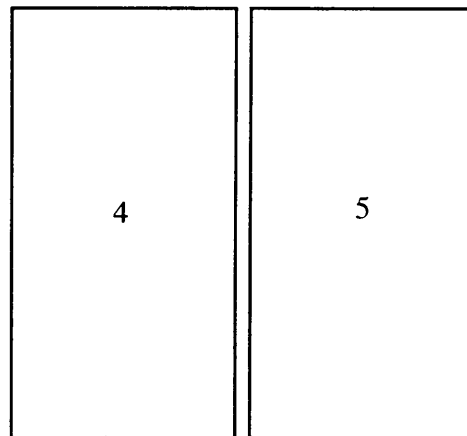

Closed

1. Virgin with Sts. John the Baptist, Catherine, John the Evangelist, and Barbara
2. Beheading of St. John the Baptist
3. St. John the Evangelist
4. Sts. James Major and Anthony with Donors
5. Sts. Agnes and Clare with Donors

Source: Blum, Shirley Neilsen. *Early Netherlandish Triptychs: A Study in Patronage*. Berkeley and Los Angeles: University of California Press, 1969.

MEMLING, HANS

Altarpiece of the Virgin Enthroned
(John Donne Triptych) (formerly
Chatsworth, Devonshire Collection)
National Gallery, London
after 1475

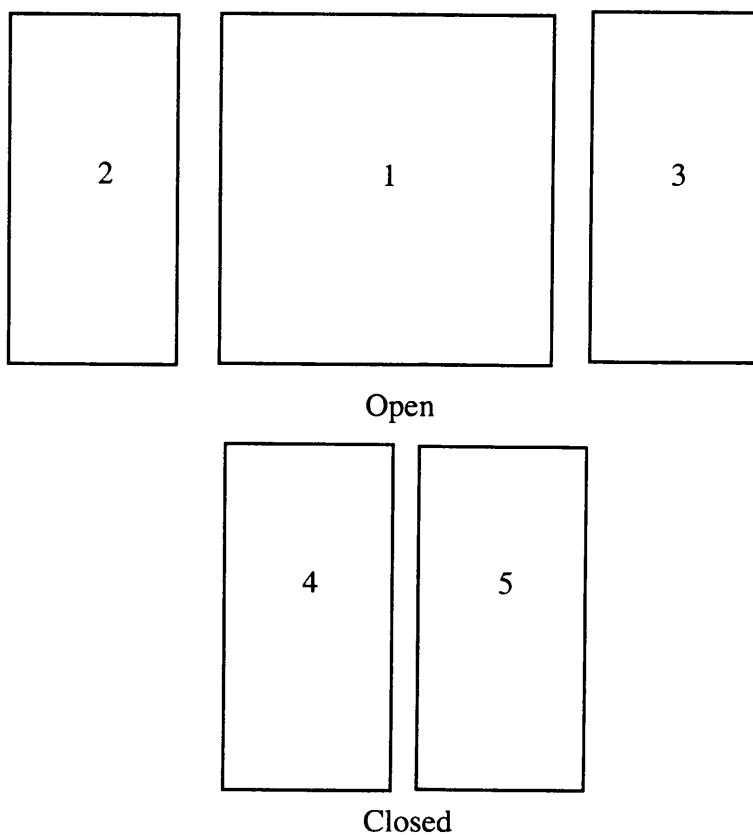

1. Virgin Enthroned with Saints, Angels and the Donor Sir John Donne of Kidwelly and His Family
2. St. John the Baptist
3. St. John the Evangelist
4. St. Christopher
5. St. Anthony Abbot

Sources: Dunkerton, Jill, et al. *Giotto to Durer: Early Renaissance Painting in the National Gallery*. New Haven: Yale University Press in association with National Gallery Publications, 1991.

Friedlander, Max J. *Early Netherlandish Painting*. Vol. 6, Pt. 1. *Hans Memlinc and Gerard David*. Leiden: A.W. Sijthoff, 1968.

St. Christopher Triptych
(Altarpiece of William Moreel)
Musee Communal, Bruges
1484

MEMLING, HANS

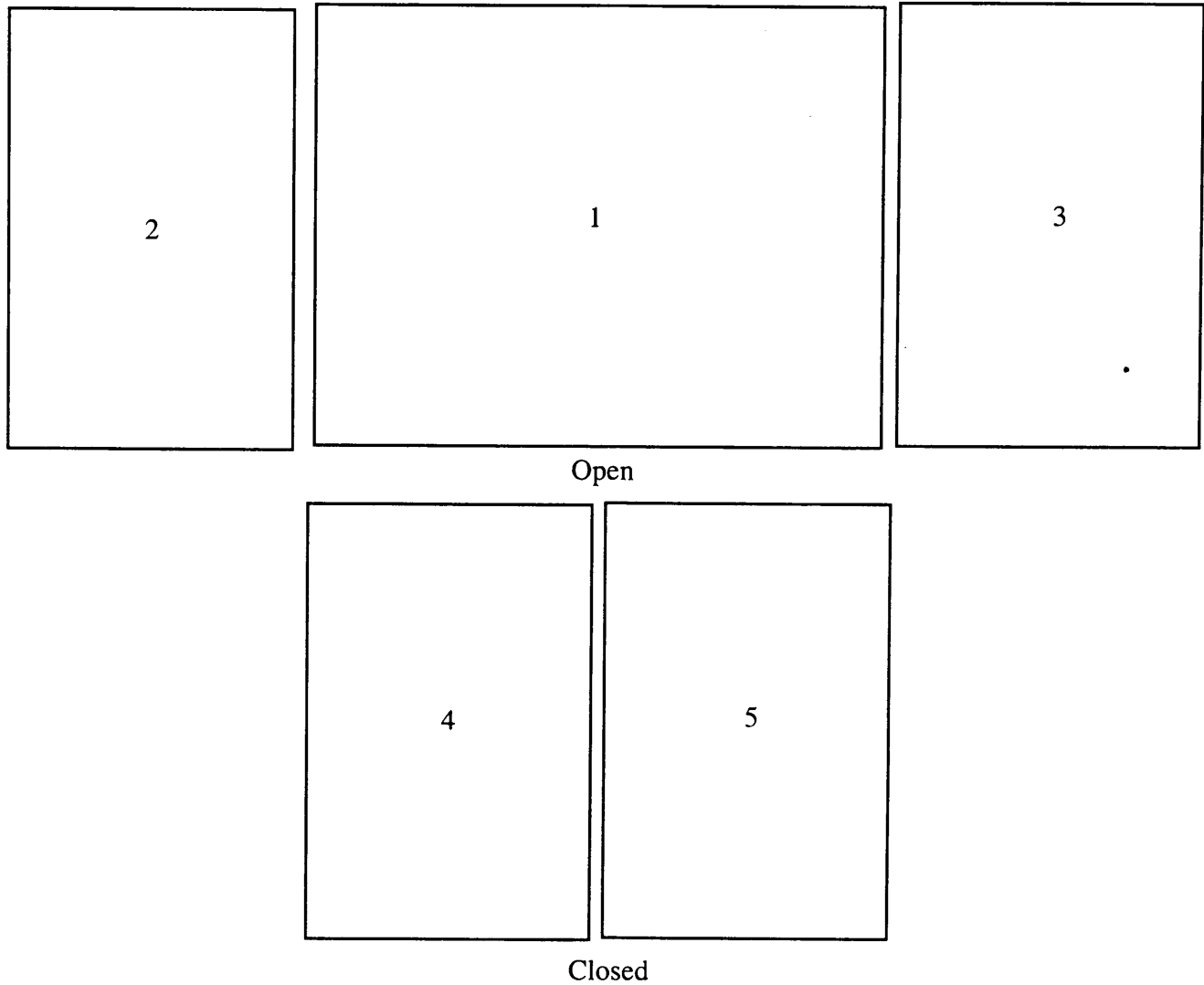

1. Sts. Christopher, Maurus, and Giles
2. St. William of Aquitaine with William Moreel and His Five Sons
3. St. Barbara with Barbara Vlaenderberghe and Her Eleven Daughters
4. St. John the Baptist
5. St. George

Source: Blum, Shirley Neilsen. *Early Netherlandish Triptychs: A Study in Patronage*. Berkeley and Los Angeles: University of California Press, 1969.

MEMLING, HANS

Shrine of St. Ursula
Memlingmuseum,
St. Janshospitaal, Bruges
1489

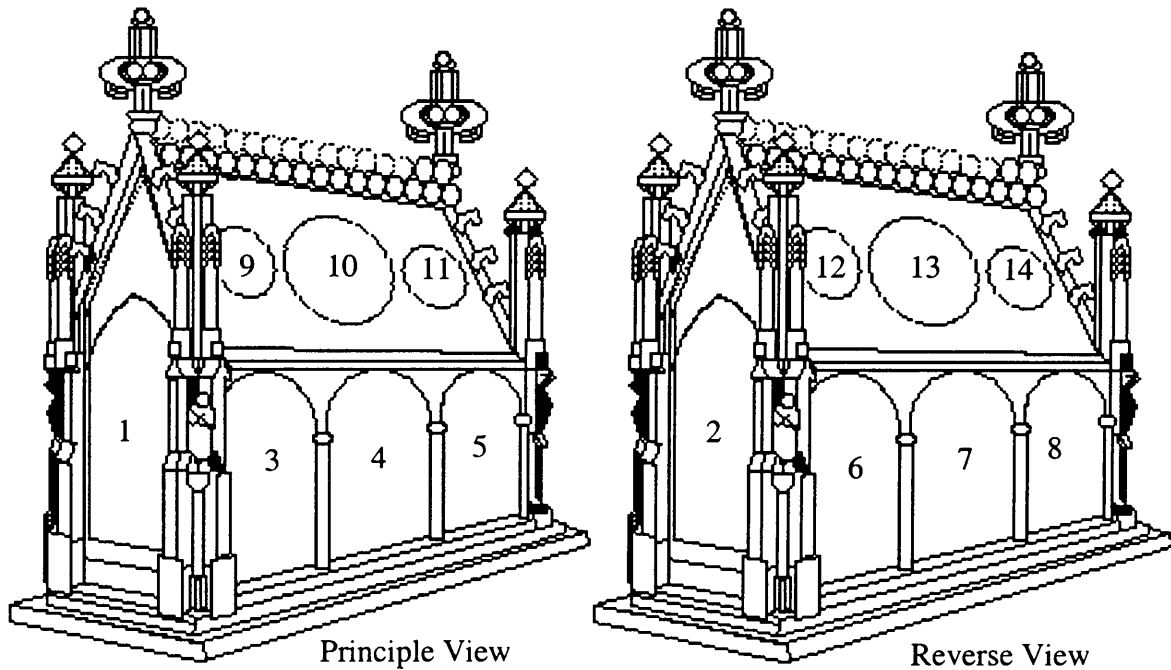

1. Virgin and Child with Two Kneeling Female Donors
2. St. Ursula with the Virgins
3. Landing in Cologne
4. Landing in Basel
5. Reception by Pope Cyriacus in Rome
6. Return Journey, Sailing from Basel
7. Attack by the Huns at Cologne
8. Martyrdom of St. Ursula
9. Angel Musician with Psalter
10. Coronation of St. Ursula
11. Angel Musician with Violin
12. Angel Musician with Cithera
13. Coronation of the Virgin
14. Angel Musician with Organ

Source: Friedlander, Max J. *Early Netherlandish Painting: Hans Memlinc and Gerard David*, Vol. 6, Pt. 1. Leiden: A.W. Sijthoff, 1968.

Deposition Altarpiece
(executed for Chapel of the
Carpenters' Guild, Antwerp Cathedral)
Royal Museum of Fine Arts
Antwerp
1508-1511

METSYS, QUINTEN

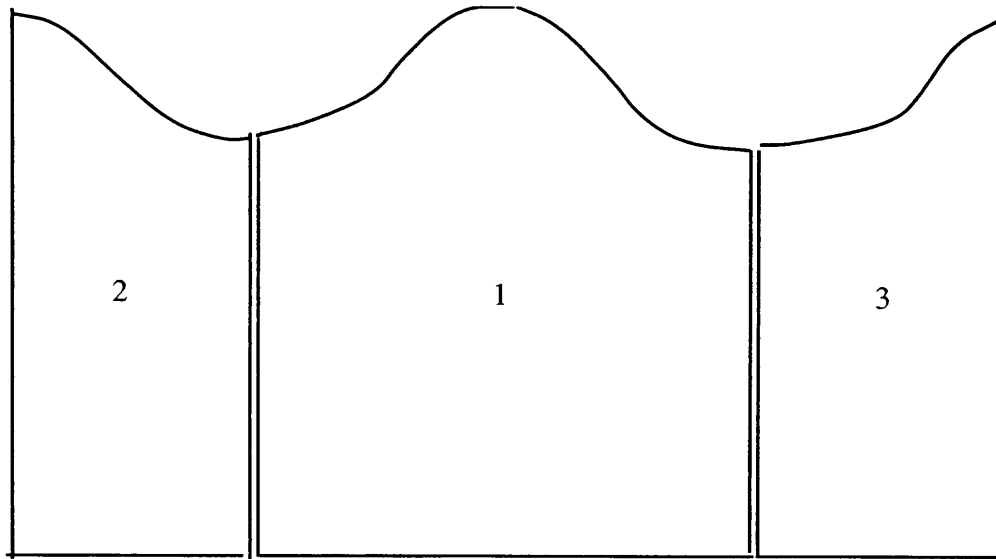

1. Descent from the Cross
2. Salome Presents the Head of St. John the Baptist to Herodias
3. Attempted Martyrdom of St. John the Evangelist Immersed in a Caldron of Boiling Oil

Source: Cuttler, Charles D. *Northern Painting from Pucelle to Bruegel: Fourteenth, Fifteenth, and Sixteenth Centuries*. New York: Holt, Rinehart and Winston, 1968.

MICHELANGELO

Ceiling Frescoes
Sistine Chapel
Vatican City
1508-12

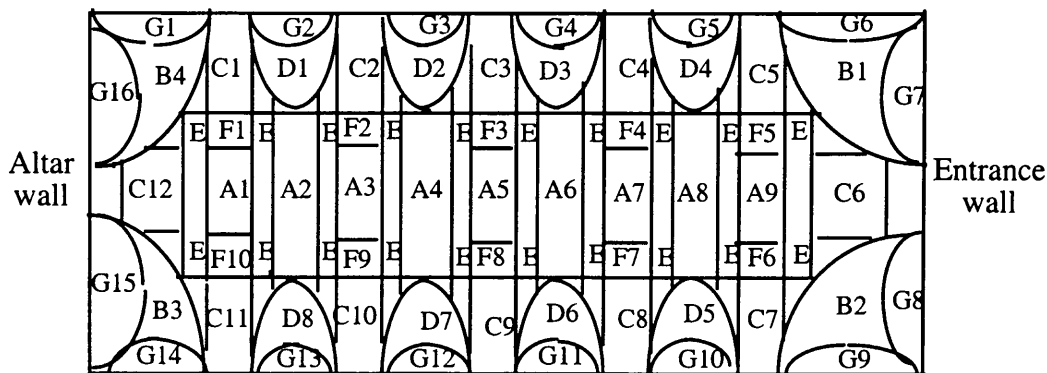

A. Top of ceiling:

1. Division of Light from Dark
2. Creation of Sun, Moon and Stars
3. Spirit of God Over the Water
4. Creation of Adam
5. Creation of Eve
6. Temptation and Expulsion
7. Sacrifice of Noah
8. The Flood
9. Drunkenness of Noah

B. Pendentives:

1. David and Goliath
2. Judith and Holofernes
3. Brazen Serpent
4. Punishment of Haman

C. Prophets and Sibyls:

1. Jeremiah
2. Persian Sibyl
3. Ezechiel
4. Erythraean Sibyl
5. Joel
6. Zacharias
7. Delphic Sibyl

8. Isaiah

9. Cumaean Sibyl
10. Daniel
11. Libyan Sibyl
12. Jonah

D. Triangular vaults above windows

1. Salmon
2. Roboam
3. Ozias
4. Zorobabel
5. Josiah
6. Ezekias
7. Asa
8. Jesse

E. Ignudo (series of 20 nude youths)

F. Medallions

1. Elias on the Chariot of Fire
2. undecorated
3. Destruction of the Tribe of Ahab
4. Destruction of the Temple of Baal
5. Death of Joram
6. Ascension of Elijah
7. Death of Uriah
8. David before Nathan
9. Death of Absalam
10. Sacrifice of Abraham

G. Lunettes over the windows

1. Aminadab
2. Salmon, Obed, and Boaz
3. Abiah
4. Achaz and Joatham
5. Abiud
6. Eliud and Achim
7. Joseph and Jacob
8. Eleazor and Matthan
9. Sadoc and Azor
10. Josias, Jeconias, and Salathiel
11. Ezechias, Manasses, and Amon
12. Asa, Josaphat, and Joram
13. David and Solomon
14. Naason
15. Phares, Esrom, and Aram
16. Abraham, Isaac, Jacob, and Judah

Sources: Honour, Hugh and John Fleming. *The Visual Arts: A History*. 3rd edition. New York: Harry N. Abrams, 1991.

Pietrangali, Carlo, et al. *The Sistine Chapel: The Art, the History, and the Restoration*. New York: Harmony Books, 1986.

Seymour, Charles, ed. *Michelangelo: The Sistine Chapel Ceiling. Study*. New York: Norton, 1972.

Last Judgement
Sistine Chapel, Vatican City
1536-41

MICHELANGELO

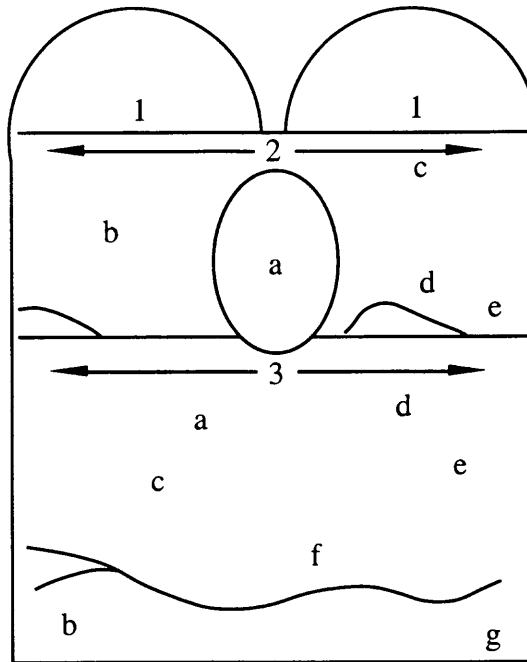

1. Lunettes

Angels in Flight Bearing Symbols of the Passion

2. Wall, upper portion

- a. The Virgin in the Shadow of Christ and the Judge, Who Condemns the Probate
- b. Groups of Saints and Blessed Awaiting the Sentence of Christ the Judge
- c. Saints and Blessed
- d. St. Bartholomew Showing Christ the Skin and Knife of His Martyrdom
- e. St. Sebastian Showing the Arrow of His Martyrdom and Repeating the Act of the Archer

3. Wall, lower portion

- a. Group of Angels with Trumpets Calling the Reborn to the Supreme Judgement
- b. Groups of the Reborn and Angels Delivering the Bodies of the Newly Risen from the Demons
- c. Groups of the Blessed Rising to Heaven Aided by the Reborn and Angels
- d. One of the Damned Held by Demons and Dragged to the Inferno
- e. The Damned Struggling and Being Thrust into the Inferno
- f. Charon Striking the Damned as They Arrive at the Threshold of the Inferno
- g. Damned Held by Demons and Judged by Minos

Sources: Mariani, Valerio. *Michelangelo, the Painter*. Milan: Arti Grafiche Ricordi, 1964.
Pietrangeli, Carlo, et al. *The Sistine Chapel: The Art, the History and the Restoration*.
New York: Harmony Books, 1986.
Salvini, Roberto. *The Sistine Chapel*. 2 vols. New York: Harry N. Abrams, 1971.

**PACHER, MICHAEL
and Workshop**

St. Wolfgang Altarpiece
Parish Church, St. Wolfgang
Austria
c.1471-81

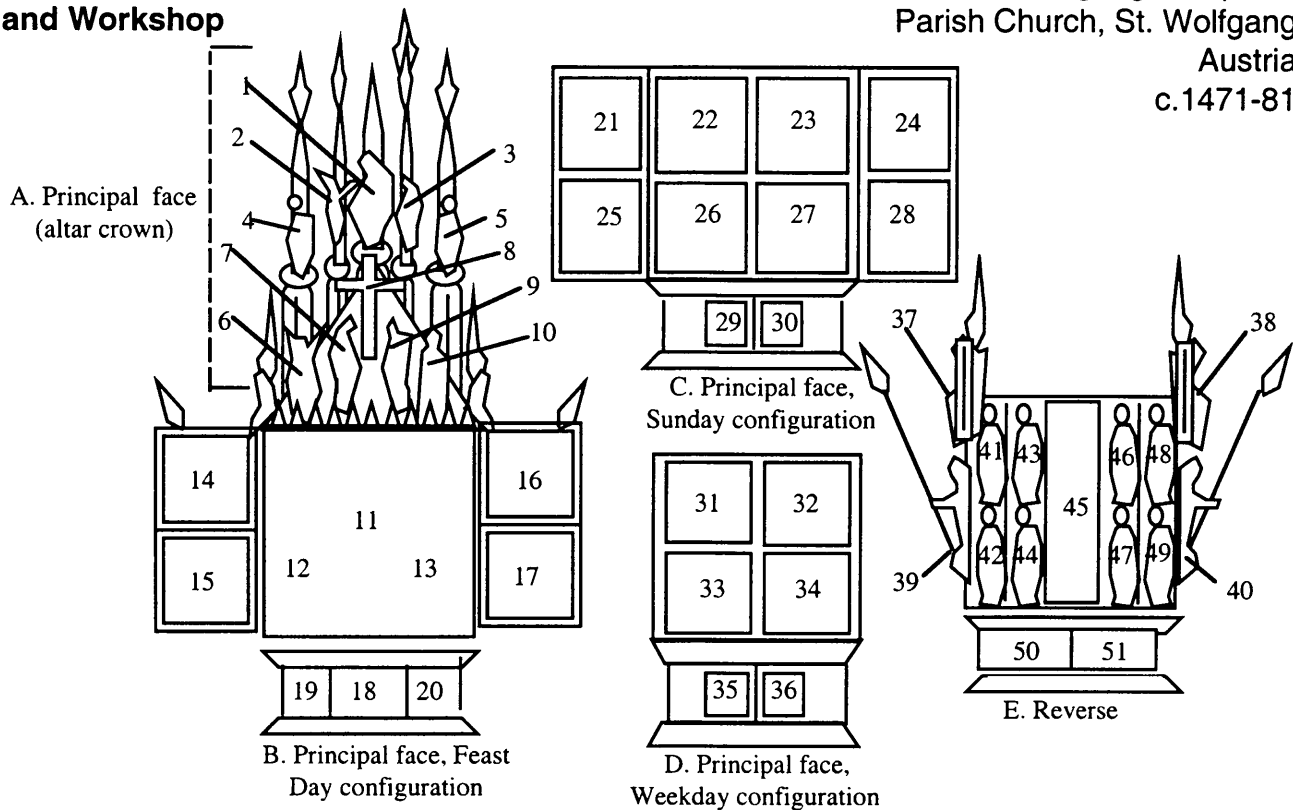

**A. Principal face, Tympanium
(altar crown)**

1. God the father
2. Angel
3. Mary
4. St. Scholastica (?)
5. St. Ottilia
6. Archangel Michael
7. Mary
8. Crucifixion
9. St. John the Evangelist
10. St. John the Baptist

B. Principal face, Feast Day configuration

11. Coronation of the Virgin (sculpture)
12. St. Wolfgang (sculpture)
13. St. Benedict (sculpture)
14. Nativity
15. Circumcision
16. Presentation in the Temple
17. Death of the Virgin
18. Adoration of the Magi (sculpture)
19. Visitation
20. Flight into Egypt

**C. Principal Face, Sunday
Configuration**

21. Baptism of Christ
22. Temptation of Christ
23. Marriage at Cana
24. Feeding of the 5,000
25. Stoning of Christ
26. Cleansing the Temple
27. Christ and the Adulteress
28. Raising of Lazarus
29. Sts. Gregory the Great and Hieronymus
30. Sts. Augustine and Ambrose

D. Principal face, Weekday configuration

31. St. Wolfgang Preaching
32. St. Wolfgang Distributing Alms
33. St. Wolfgang Building a Church
34. St. Wolfgang Healing the Possessed
35. Sts. Gregory the Great and Hieronymus
36. Sts. Augustine and Ambrose

E. Reverse

37. St. Margaret
38. St. Catherine
39. St. George
40. St. Florian
41. St. Othmar
43. St. Erasmus
44. St. Ulrich
45. St. Christopher
46. St. Hubert
47. St. Clare
49. St. Elizabeth of Thuringen
50. Sts. Mark and Luke
51. Sts. John and Matthew

Sources: Koller, Manfred and Norbert Wibiral. *Der Pacher-Altar in St. Wolfgang: Untersuchung, Konservierung und Restaurierung, 1969-1976*. Vienna: Herman Bohlau, 1981.

Rasmo, Nicolo. *Michael Pacher*. London: Phaidon Press, 1971.

Snyder, James. *Northern Renaissance Art: Painting, Sculpture, the Graphic Arts from 1350 to 1575*. New York: Harry N. Abrams, 1985.

Pala d' Oro Cover
 (executed for the Basilica of San Marco, Venice)
 Museo di San Marco, Venice
 1345

PAOLO DA VENEZIA
 with his sons **LUCA** and
GIOVANNI

1	2	3	4	5	6	7
8	9	10	11	12	13	14

1. St. George
2. St. Mark
3. Virgin
4. Man of Sorrows
5. St. John the Evangelist
6. St. Peter
7. St. Nicholas
- The Life, Death and Miracles of St. Mark:
8. St. Peter Blessing St. Mark
9. St. Mark Healing Anianus
10. Christ Appearing to St. Mark in Prison
11. Martyrdom of St. Mark
12. St. Mark Saving the Ship Transporting His Body to Venice
13. Discovery of the Relics
14. Tomb of St. Mark

Source: Muraro, Michelangelo. *Paolo da Venezia*. University Park and London: Pennsylvania State University Press, 1970.

**PAOLO DA VENEZIA
and Workshop**

Polyptych with St. Clare
Galleria dell'Accademia
Venice
1354-58

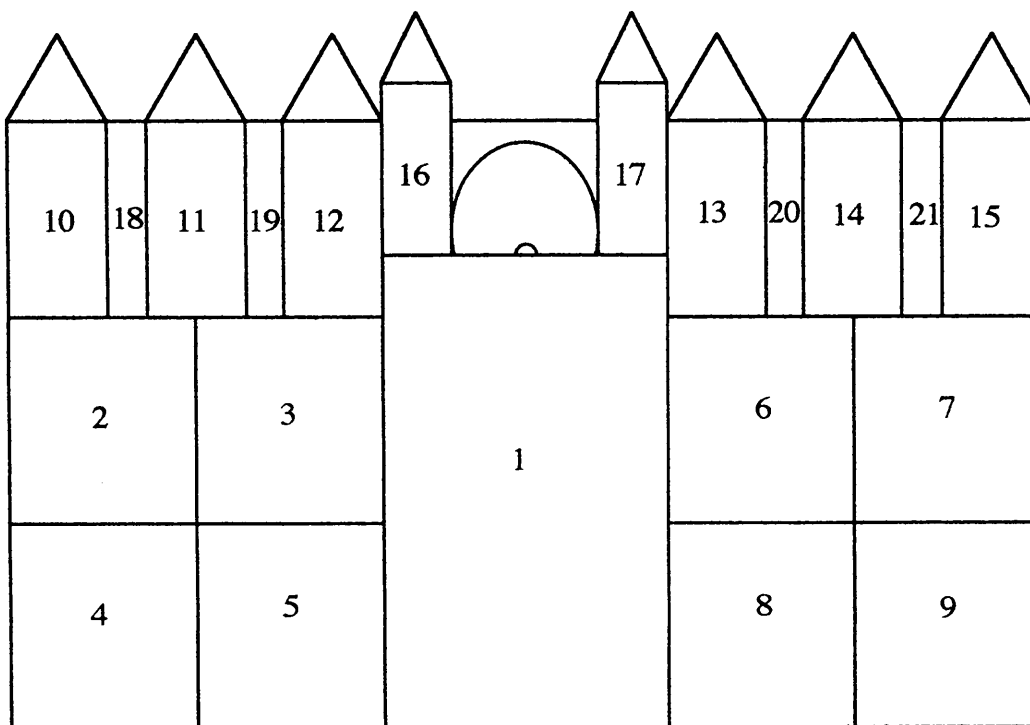

- | | |
|--|--|
| 1. Coronation of the Virgin | 10. Pentecost |
| 2. Nativity and Adoration of the Magi | 11. St. Clare Taking the Veil |
| 3. Baptism of Christ | 12. St. Francis Repudiating His Father |
| 4. Last Supper | 13. Stigmatization |
| 5. Kiss of Judas and Agony in the Garden | 14. Death of St. Francis |
| 6. Way to Calvary | 15. Christ in Judgement |
| 7. Crucifixion | 16. Prophet Isaiah |
| 8. Resurrection and Noli me tangere | 17. Prophet David |
| 9. Ascension | 18-21. The Four Evangelists |

Source: Muraro, Michelangelo. *Paolo da Venezia*. University Park and London: The Pennsylvania State University Press, 1970.

Astrological Frescoes, Loggia Vault
Villa Farnesina, Rome
c.1511

PERUZZI, BALDASSARE

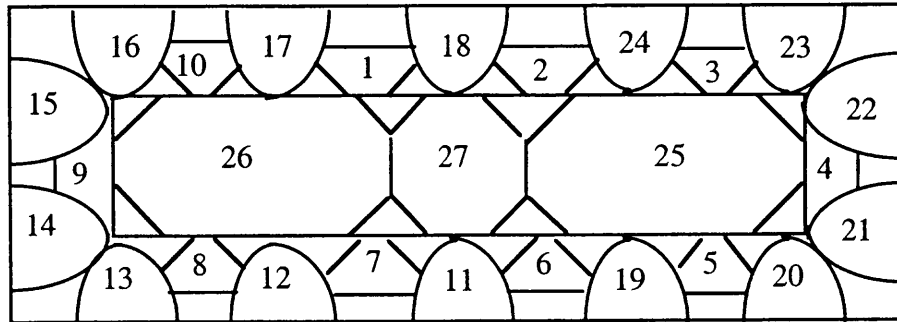

Spandrels

(Zodiacal signs and planets under their antique personifications.)

1. Aries, Taurus and Personification of the Planet Jupiter
2. Gemini
3. Cancer
4. Leo
5. Virgo with the Moon Personified as Diana the Huntress
6. Libra, Scorpio and Godly Forms of Mars and Mercury
7. Sagittarius with Apollo as the Sun
8. Capricorn and Venus
9. Aquarius
10. Pisces and Saturn

Severies

(Classical figures representing 14 extra-zodiacal star groups.)

11. The Altar
12. The Lyre
13. The Arrow
14. The Dolphin
15. The Bird or Swan
16. The Horse Pegasus
17. The Triangle
18. The River Eridanus
19. The Northern Crown
20. The Crater
21. The Hydra
22. The Dog
23. The Ship
24. The Charioteer

Ceiling panels

(Constellations and shield.)

25. Constellation of the Wain or Chariot Driven by Either Cynosura or Helice
26. Constellation of Perseus, Shown About to Decapitate Medusa, with Victims Turned to Stone; Floating Figure (who may be Fame or Virgo); and a Horse's Head at the Lower Right, Probably Pegasus
27. Agostino Chigi's Shield (Originally Sign of Sagittarius, Now the Duke of Ripalta's Shield)

Sources: Quinlan-McGrath, Mary. "The Astrological Vault of the Villa Farnesina: Agostino Chigi's Rising Sign." *Journal of the Warburg and Courtauld Institutes*, 47 (1984): 6-10.

Saxl, Fritz. *La fede astrologica di Agostino Chigi: interpretazione dei dipinti di Baldassare Peruzzi nella Sala di Galatea della Farnesina*. Rome: Reale Accademia d'Italia, 1934.

**PIERO DELLA FRANCESCA
and BICCI DI LORENZO**

**Legend of the True Cross
Choir Chapel, San Francesco, Arezzo
1447-51?**

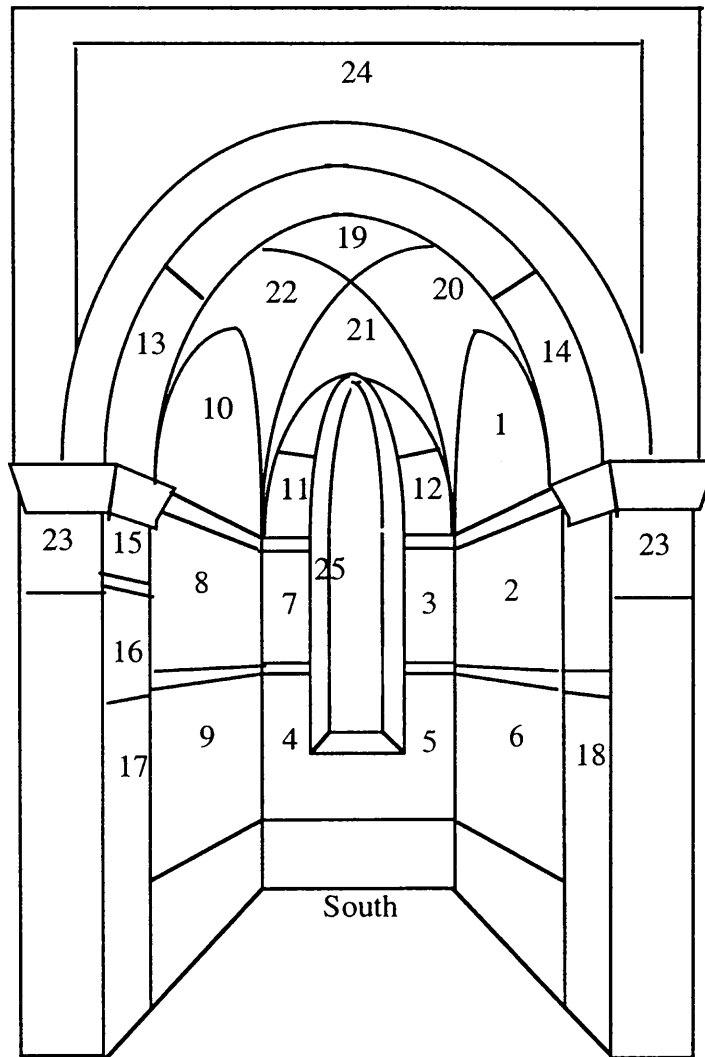

- | | | |
|--|---|--------------------------------------|
| 1. Death of Adam | 9. Battle of Heraclius and
Death of Chosroes | 18. St. Michael Archangel |
| 2. Sheba Venerating the Wood and
Meeting of Soloman and Sheba | 10. Exultation of the Cross | 19. Bicci di Lorenzo. St. Matthew |
| 3. Burial of the Wood | 11. Ezekiel (?) | 20. Bicci di Lorenzo. St. Luke |
| 4. Annunciation | 12. Jeremiah (?) | 21. Bicci di Lorenzo. St. John |
| 5. Constantine's Vision | 13. St. Augustine | 22. Bicci di Lorenzo. St. Mark |
| 6. Victory of Constantine | 14. St. Ambrose | 23. Bacci Coat of Arms |
| 7. Raising of Judas from the Well | 15. St. Blind Cupid | 24. Bicci di Lorenzo. Last Judgement |
| 8. Finding and Proofing of the Cross | 16. St. Louis of Toulouse | 25. St. Bernardino of Siena |
| | 17. St. Peter Martyr (fragment) | |

Sources: Borsook, Eve. *The Mural Painters of Tuscany: From Cimabue to Andrea del Sarto*. 2nd ed. Oxford: Clarendon Press, 1980.

Lavin, Marilyn Aronberg. *Piero della Francesca: San Francesco, Arezzo*. New York: George Braziller, 1994.

Roettgen, Steffi. *Italian Frescoes*. Vol. 1, *The Early Renaissance, 1400-1470*. New York, London and Paris: Abbeville Press, 1996.

Polyptych of the Misericordia
(reconstruction)
Pinacoteca, Sansepolcro
1445-c.1460

PIERO DELLA FRANCESCA

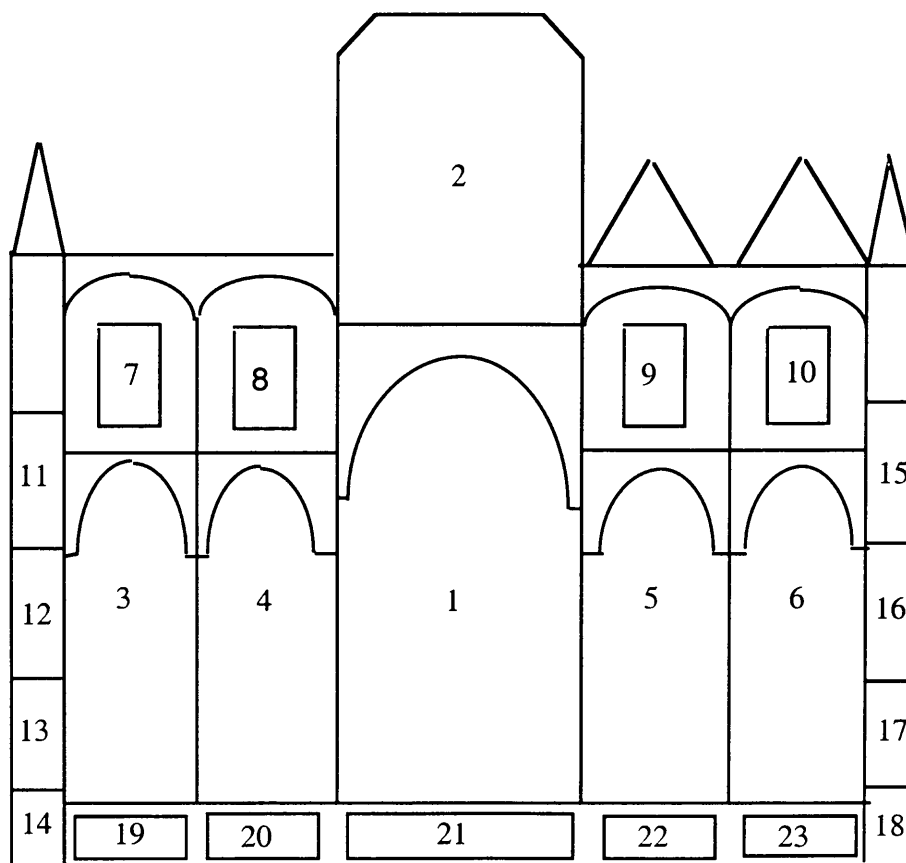

- | | | |
|-------------------------------|-------------------------------|------------------------------|
| 1. Madonna della Misericordia | 10. St. Francis | 19. Agony in the Garden |
| 2. Crucifixion | 11. St. Jerome | 20. Flagellation |
| 3. St. Sebastian | 12. St. Anthony of Padua | 21. Deposition |
| 4. St. John the Baptist | 13. San Arcano | 22. Noli me tangere |
| 5. St. John the Evangelist | 14. Badge of the Misericordia | 23. Three Maries at the Tomb |
| 6. St. Bernardino of Siena | 15. St. Augustine | |
| 7. St. Romuald | 16. St. Dominic | |
| 8. Angel of the Annunciation | 17. St. Egidius | |
| 9. Virgin of the Annunciation | 18. Badge of the Misericordia | |

Source: Bertelli, Carlo. *Piero della Francesca*. New Haven: Yale University Press, 1992.
 Cole, Bruce. *Piero della Francesca: Tradition and Innovation in Renaissance Art*. New York: Icon Editions, 1991.
 Salmi, Mario. *La pittura di Piero della Francesca*. Novara: Istituto geografico De Agostini, 1979.

PIERO DELLA FRANCESCA

Saint Anthony Altarpiece
Galleria Nazionale dell'Umbria, Perugia
1460-70

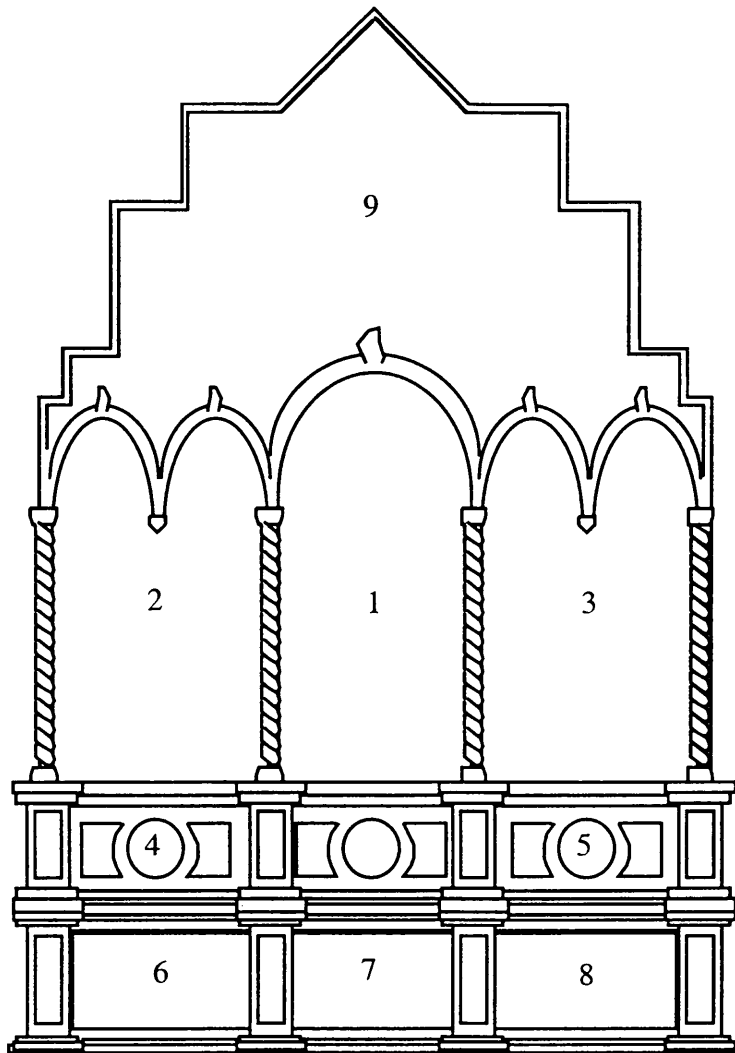

Central portion

1. Madonna and Child Enthroned
2. Sts. Anthony of Padua and John the Baptist
3. Sts. Francis and Elizabeth of Hungary

Roundels

4. St. Clare
5. St. Agatha

Predella panels

6. St. Anthony Resurrecting a Child
7. Stigmatization
8. St. Elizabeth Saving a Child from a Well

Top

9. Annunciation

Sources: Lavin, Marilyn Aronberg. *Piero della Francesca: San Francesco, Arezzo*. New York: George Braziller, 1994.

Salmi, Mario. *La pittura di Piero della Francesca*. Novara: Istituto geografico De Agostini, 1979.

Campanile Hexagonal Reliefs
 Museo dell'Opera del Duomo, Florence
 c.1337-43; 15c

PISANO, ANDREA
and Workshop
LUCA DELLA ROBBIA

West face

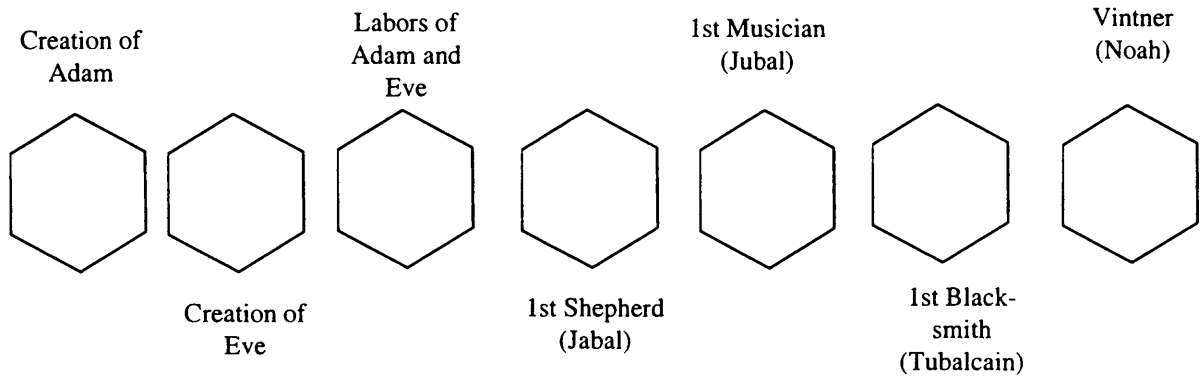

South face

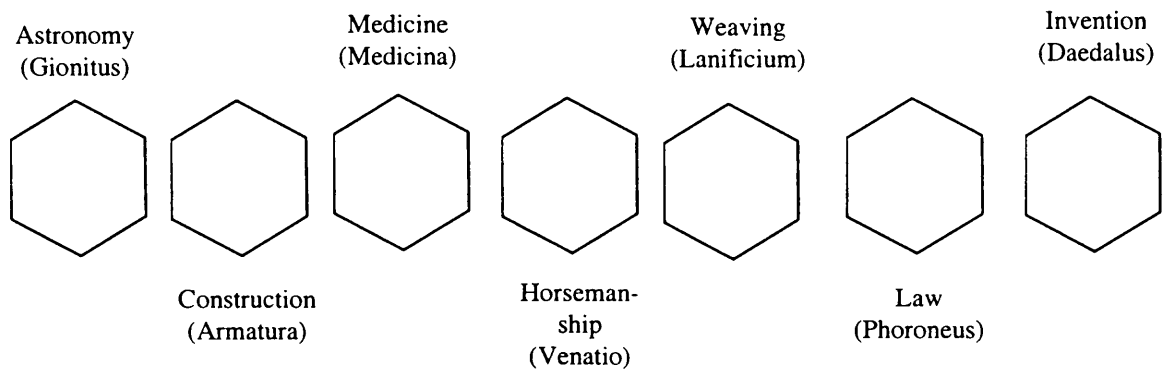

East face

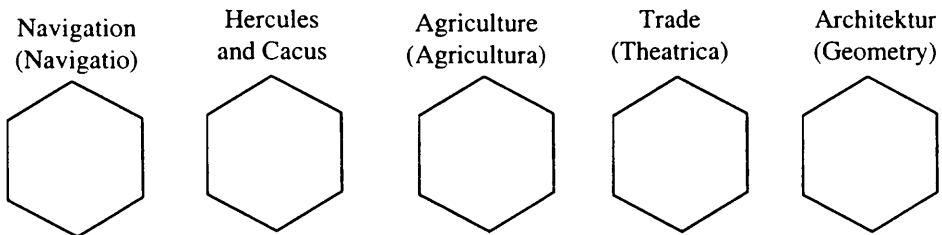

North face

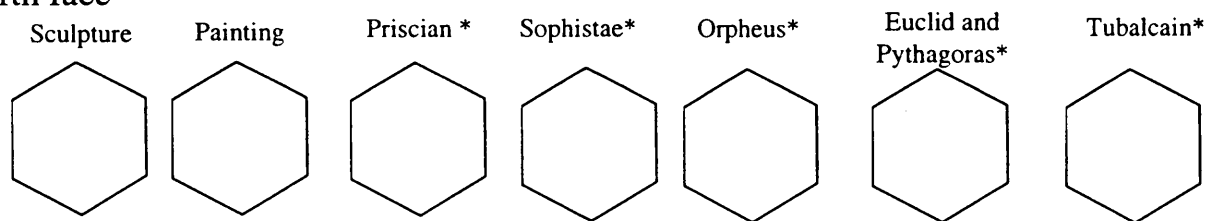

*These Five hexagonal reliefs were carved by Luca della Robbia in the fifteenth century.

Source: Moskowitz, Anita Fiderer. *The Sculpture of Andrea and Nino Pisano*. Cambridge: Cambridge University Press, 1986.

1	2	15	16
3	4	17	18
5	6	19	20
7	8	21	22
9	10	23	24
11	12	25	26
13	14	27	28

- | | |
|---|--|
| 1. Annunciation to Zacharias | 15. St. John the Baptist before Herod |
| 2. Zacharius Dumbstruck | 16. St. John the Baptist Led to Prison |
| 3. Visitation | 17. St. John's Disciples Visit Him in Prison |
| 4. Birth of St. John the Baptist | 18. Christ and John's Apostles |
| 5. Naming of St. John the Baptist | 19. Dance of Salome |
| 6. Young St. John in the Wilderness | 20. Beheading of St. John the Baptist |
| 7. St. John Preaching to the Multitude | 21. St. John the Baptist's Head Brought to Herod |
| 8. Behold the Lamb | 22. Salome Presents the Head of St. John the Baptist to Herodias |
| 9. St. John the Baptist Baptizes the People | 23. John's Disciples Take Away His Body |
| 10. Baptism | 24. Entombment of John the Baptist |
| 11. Hope | 25. Charity |
| 12. Faith | 26. Humility |
| 13. Fortitude | 27. Justice |
| 14. Temperance | 28. Prudence |

Sources: Carli, Enzo. *Sculpture of Italy*. Milan: Electa, 1967.

Finn, David, et al. *The Florence Baptistry Doors*. New York: Viking Press, 1980.

Pulpit
Cathedral, Pisa
1302-10

PISANO, GIOVANNI

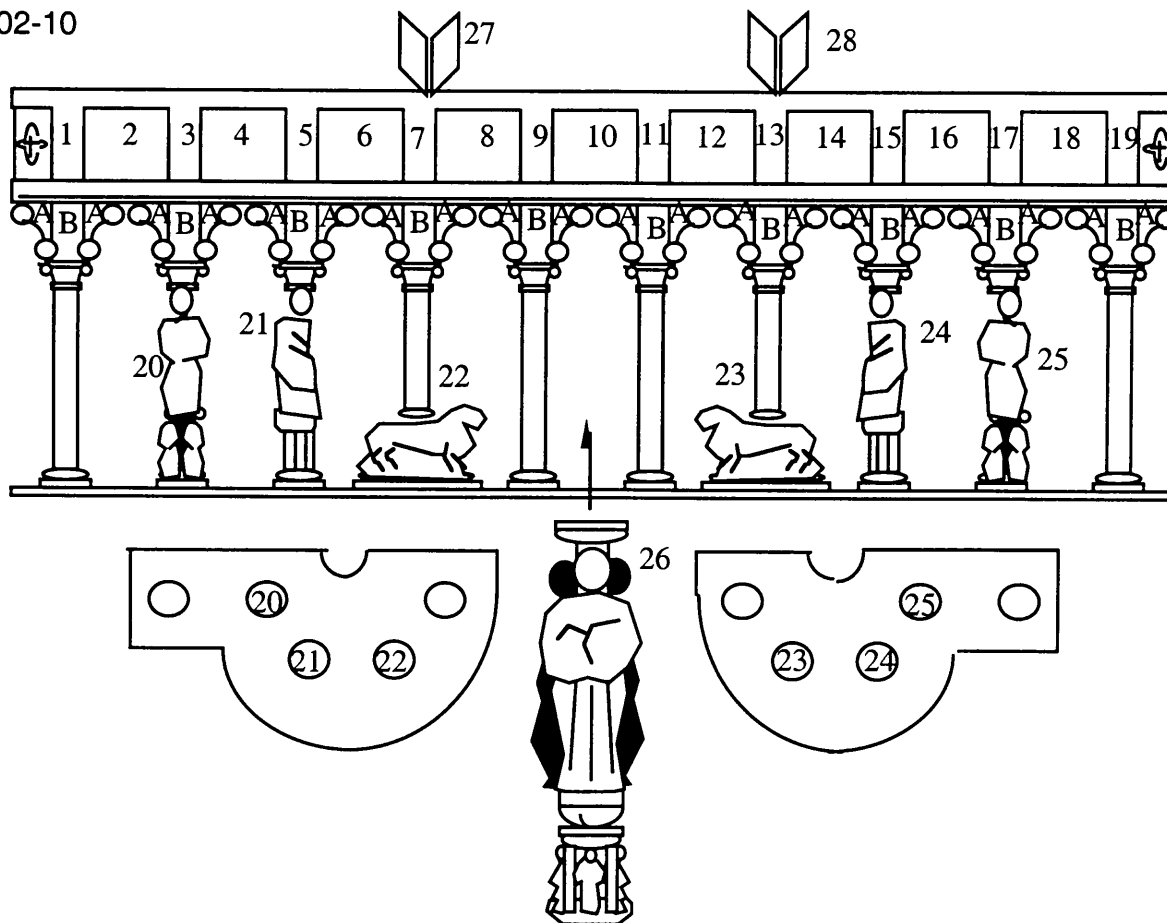

- | | |
|---------------------------------------|--|
| 1. Ornament of a Later Date | 18. Last Judgement |
| 2. Birth of St. John the Baptist | 19. Ornament of Later Date |
| 3. Isaiah | 20. Ecclesia and Cardinal Virtues: Prudence, Fortitude, Temperance, and Justice |
| 4. Nativity | 21. Hercules or Samson |
| 5. Apocalyptic Christ | 22. Lion with Stag |
| 6. Adoration of the Magi | 23. Lion with Horse |
| 7. David | 24. St. Michael |
| 8. Presentation and Flight into Egypt | 25. Christ and the Four Evangelists with Figures of Atlas and Donor. (Donor by Nello di Falcone) |
| 9. Jeremiah | 26. Liberal Arts and Theological Virtues (Base) |
| 10. Massacre of the Innocents | 27. Gospel Lectern in the Form of an Eagle |
| 11. Prophet (modern) | 28. Corpus Christi Lectern |
| 12. Passion of Christ | A's: Prophets with Scrolls and Evangelist Symbols (Spandrel Figures) |
| 13. Malachi | B's: Sibyls |
| 14. Crucifixion | |
| 15. Sts. Peter and Paul | |
| 16. The Elect | |
| 17. Christ in Judgment | |

Sources: Ayrtton, Michael. *Giovanni Pisano: Sculptor*. New York: Weybright and Talley, Inc., 1969.

Carli, Enzo. *Giovanni Pisano*. Pisa: Pacini, 1977.

Keller, Harald. *Giovanni Pisano*. Vienna: Anton Schroll, 1942.

Mellini, Gian Lorenzo. *Giovanni Pisano*. Milan: Electa, 1970.

Venturi, Adolfo. *Giovanni Pisano: sein Leben und sein Werk*, Vol.1. Florence: Pantheon, 1927.

PISANO, GIOVANNI

Pulpit of Pistoia
Sant' Andrea, Pistoia
1298-1301

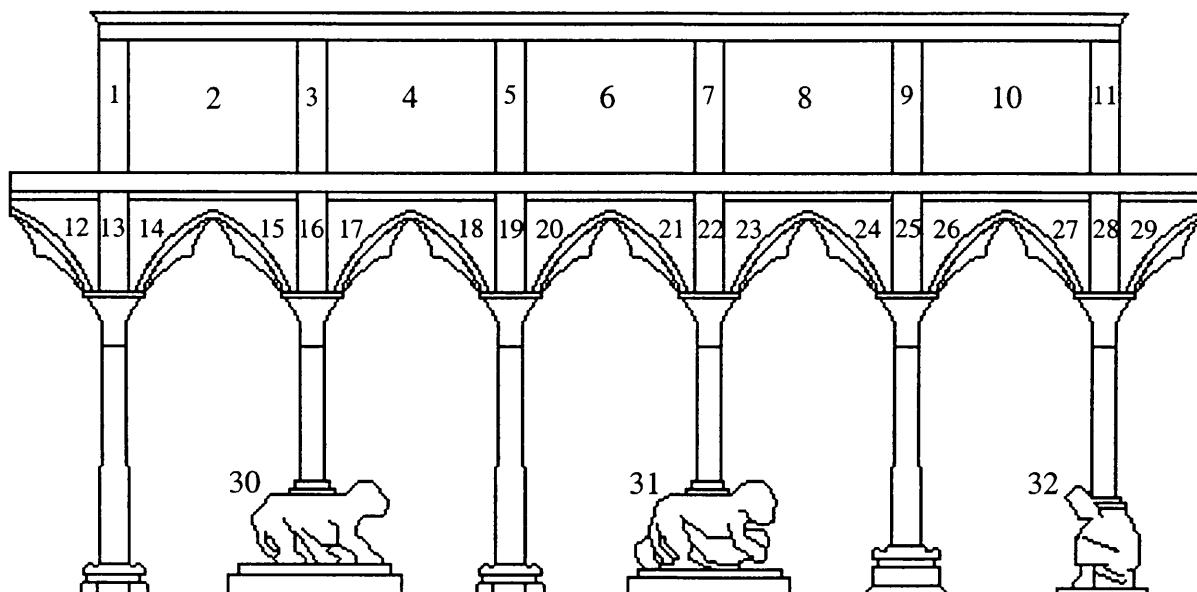

- | | |
|------------------------------|---------------------|
| 1. St. Stephen | 17. Third Prophet |
| 2. Annunciation and Nativity | 18. Fourth Prophet |
| 3. Apocalyptic Christ | 19. Third Sibyl |
| 4. Adoration of the Magi | 20. David |
| 5. St. Andrea | 21. Solomon |
| 6. Massacre of the Innocents | 22. Fourth Sibyl |
| 7. Tetromorph | 23. Fifth Prophet |
| 8. Crucifixion | 24. Sixth Prophet |
| 9. Apostle | 25. Fifth Sibyl |
| 10. Last Judgement | 26. Seventh Prophet |
| 11. Angels | 27. Eighth Prophet |
| 12. St. Peter | 28. Sixth Sibyl |
| 13. First Sibyl | 29. St. Paul |
| 14. First Prophet | 30. Lioness |
| 15. Second Prophet | 31. Lion |
| 16. Second Sibyl | 32. Adam |

Source: Ayrton, Michael. *Giovanni Pisano: Sculptor*. New York: Weybright and Talley, Inc., 1969
Carli, Enzo. *Giovanni Pisano: Il Pulpito di Pistoia*. Milan: G. Mandadori and Associates, 1986.

Carli, Enzo. *Giovanni Pisano*. Pisa: Pacini, 1977.

Sacraments, Series I

executed for Cassiano dai Pozzo
1636-42

Belvoir Castle, Grantham, Collection of
the Duke of Rutland and
Washington, DC, National Gallery of Art

Baptism. 1636-40. Washington, DC.,
National Gallery of Art
Confirmation
Eucharist
Penance (destroyed; copy in New York,
Private Collection)
Extreme Unction
Ordination
Marriage

Sacraments, Series II

executed for Paul Freart de Chantelou
1645-48

Collection of the Duke of Sutherland,
on loan to Edinburgh, National Gallery
of Scotland

Baptism. 1646
Confirmation. 1645
Eucharist. 1647
Penance. 1647
Extreme Unction. 1644
Ordination. 1647
Marriage. 1647-48

Sources: Blunt, Anthony. *Nicolas Poussin*. 2 vols. New York: Bollingen Foundation, 1967.
Merot, Alain. *Nicolas Poussin*. New York: Abbeville Press, 1990.
Verdi, Richard. *Nicolas Poussin, 1594-1665*. London: Royal Academy of Arts, 1995.

RAPHAEL

Leo X Vatican Tapestries Series
 (reconstructed hanging order)
 Sistine Chapel, Vatican City
 16c

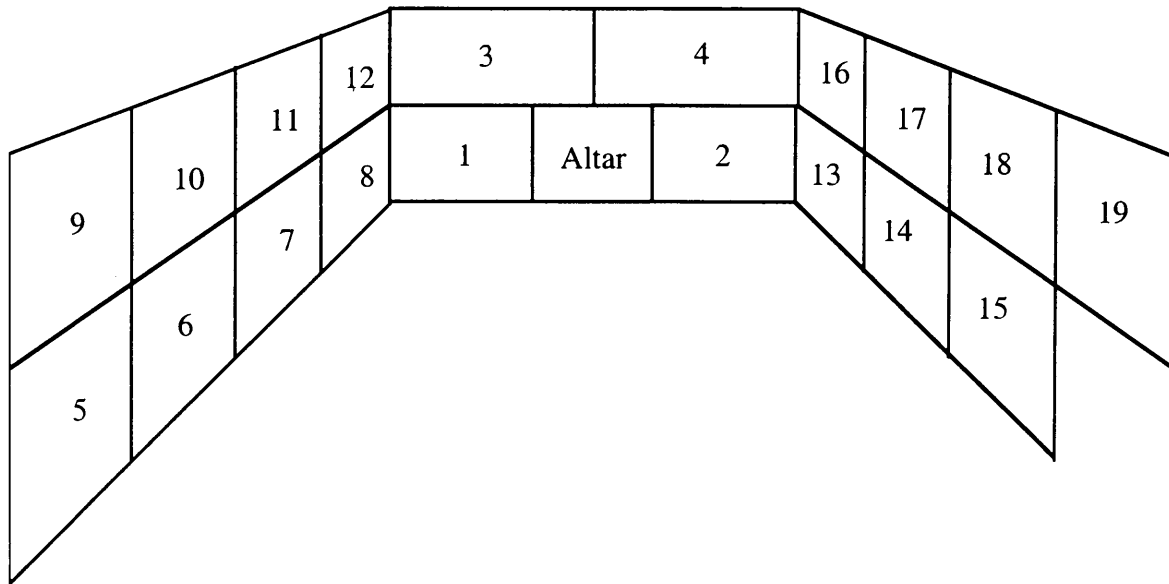

Altar wall

- 1. Stoning of St. Stephen
- 2. Miraculous Draught of Fishes
- 3. Finding of Moses
- 4. Nativity

Left wall

- 5. St. Paul at Athens
- 6. Sacrifice at Lystra
- 7. Conversion of Proconsul
- 8. Conversion of Saul
- 9. Adoration of the Golden Calf

- 10. Crossing of the Red Sea
- 11. Moses in Egypt
- 12. Circumcision

Right wall

- 13. Charge to St. Peter
- 14. Healing of Lame Man
- 15. Death of Ananias
- 16. Baptism
- 17. Healing of Leper
- 18. Calling of Apostles
- 19. Sermon on the Mount

Source: Shearman, John. *Raphael's Cartoons in the Collection of Her Majesty the Queen and the Tapestries for the Sistine Chapel*. London: Phaidon Press, 1972.

**Madonna's
(Paintings only)**

RAPHAEL

Madonna and Child Holding a Goldfinch (Solly Madonna)	1500-01 (d) c.1500 (p)	Berlin, Staatliche Museen
Madonna with Child Blessing Sts. Jerome and Francis	c.1502 (d)	Berlin, Staatliche Museen
Madonna and Child with the Infant St. John (Madonna Diotalevi)	c.1502 (d)	Berlin, Staatliche Museen
Madonna and Child with St. John the Baptist and a Little Boy (Madonna Terranuova)	1504-05 (p)	Berlin, Staatliche Museen
Madonna and Child (Colonna Madonna)	1508 (d)	Berlin, Staatliche Museen
Madonna and Child with the Young St. John	1508-10 (p)	Budapest, Museum of Fine Arts
Madonna and Child (Madonna Orleans)	1505-06(d) 1507(p)	Chantilly, Musee Conde
Madonna Standing on Clouds with Sts. Sixtus and Barbara (Sistine Madonna)	1512-13(d&p)	Dresden, Gemaldegalerie
Madonna and Child (Bridgewater Madonna)	c.1508 (d)	Edinburgh, National Gallery of Scotland, Lent by Duke of Sutherland
Holy Family Meeting the Infant St. John the Baptist (Madonna del Passeggio)	c.1516-18 (d)	Edinburgh, National Gallery of Scotland, Lent by Duke of Sutherland
Holy Family under the Palm Tree	1507 (p)	Edinburgh, National Gallery of Scotland, Lent by Duke of Sutherland
Madonna and Child (Madonna del Granduca)	1505 (d) c.1505 (p)	Florence, Palazzo Pitti
Madonna Enthroned with Sts. Bernard, Peter and Augustine (Madonna del Baldacchino)	1507 (p)	Florence, Palazzo Pitti
Madonna and Child with the Young St. John (Madonna della Sedia)	c.1513-14 (d) c.1515(p)	Florence, Palazzo Pitti
Madonna and Child with the Young St. John, Sts. Elizabeth and Catherine (Madonna del' Impannata (workshop) (p)	c.1514 (d)	Florence, Palazzo Pitti
Madonna and Child with the Young St. John Holding a Goldfinch (Madonna del Cardellino)	1506 (d&p)	Florence, Uffizi
Holy Family	c.1502 (d)	London, Sir Brian Mountain Collection
Madonna Enthroned with the Child, Sts. John the Baptist and Nicholas of Bari (Ansidei Madonna)	1505(d&p) c.1505 (cd)	London, National Gallery
Madonna and Child with the Young St. John (Madonna Aldobrandini or Garvagh Madonna)	1509-10 (d) prob.1510-12 (cd)	London, National Gallery
Madonna and Child (Mackintosh Madonna or Madonna of the Tower)	c.1511 (cd)	London, National Gallery
Madonna of the Veil (Madonna di Loreto)	c.1509 (pc)	Los Angeles, J. Paul Getty Museum
Madonna and Child Enthroned with the Archangel Raphael, Tobias and St. Jerome (Madonna of the Fish or Madonna del Pesce)	1513-14 (d) after 1517 (p)	Madrid, Prado
Holy Family under an Oak Tree with the Young St. John (Madonna della Quercia) (probably by Guilio Romano and Raffaellino del Colle (p)	n.d.	Madrid, Prado
Holy Family with the Young St. John (Madonna of the Rose or Madonna della Rosa (and Workshop) (d)	c.1518-20 (d)	Madrid, Prado
Holy Family with the Sheep	1507 (inscrib.) (p)	Madrid, Prado

cd=London National Gallery of Art CD-ROM; d=Dussler; p=Pope-Hennessy; pc=Pedretti; pr=Prado Museum

RAPHAEL

Madonna's
(Paintings only)

Holy Family with St. Elizabeth and the Young St. John (Canigiani Holy Family or Canigiani Madonna)	c.1505 (d) 1507 (p)	Munich, Alte Pinakothek
Madonna and Child (Madonna Tempì)	1507(d) 1507-08(p)	Munich, Alte Pinakothek
Madonna and Child with the Child and the Young St. John (Madonna del la Tenda)	c.1513-14 (d) c.1514 (p)	Munich, Alte Pinakothek
Madonna Enthroned with the Child and the Young St. John, Sts. Peter, Cecelia, Paul and Catherine (Pala Colonna or Colonna Altarpiece)	1504-05 (d) c.1505 (p)	New York City, Metropolitan Museum of Art
Madonna and Child	c.1502-03 (d)	New York City, Private Collection
Holy Family with St. Elizabeth, the Young St. John and Angels (Madonna of Francis I)	1518 (p)	Paris, Louvre
Madonna and Child with the Young St. John (La belle Jardiniere)	1507(d &p)	Paris, Louvre
Madonna and Child with St. Joseph (Madonna di Loreto)	c.1509 [d] (original version)	Paris, Louvre
Madonna and Child with the Infant St. John (Madonna with the Diadem)	c.1512 (d)	Paris, Louvre
Madonna and Child (Madonna Conestabile)	1502-03 (d) 1504 (p)	St. Petersburg, Hermitage
Holy Family	c.1506-07 (d)	St. Petersburg, Hermitage
Virgin and Child with the Infant St. John the Baptist (Piccolomini Madonna)	c.1508 (pc)	Vaduz, A.B. Collection (formerly Piccolomini Collection, Siena)
Holy Family with the Lamb	1504 (pc)	Vaduz, H.P. Collection (formerly Viscount Lee Fareham)
Madonna and Child Worshipped by Sts. John the Baptist, Francis, Jerome and the Donor (Madonna of Foligno)	completed 1512 (d)	Vatican City, Vatican Museums
Madonna and the Child with the Young St. John (Madonna of the Meadow)	1506 inscr. (d&p)	Vienna, Kunsthistorisches Museum
Madonna and Child (Large Cowper Madonna)	1508 (d&p)	Washington, D.C., National Gallery of Art
Madonna and Child (Small Cowper Madonna)	c.1505 (d) 1504-05 (p) 1505 (wng)	Washington, D.C., National Gallery of Art
Madonna and Child with the Young St. John (Alba Madonna)	1511(d) c.1510(p) 1510 (wng)	Washington, D.C., National Gallery of Art

cd=London, National Gallery; d=Dussler; p=Pope-Hennessey; pc=Pedretti; wng=Washington, DC., National Gallery of Art

Sources: Dussler, Luitpold. *Raphael: a Critical Catalogue of his Pictures, Wall-Paintings and Tapestries*. London: Phaidon Press, 1971.

Microsoft Art Gallery: The Collection of the National Gallery, London. Redmond, Washington: Microsoft Corporation, 1993.

Museo del Prado: inventario general de pinturas, Vol.1: La coleccion real. Madrid: Museo del Prado, 1990.

National Gallery of Art, Washington, DC. www.nga.gov/home.htm.

National Gallery of Scotland: Concise Catalogue of Paintings. Edinburgh: Trustees of the National Gallery of Scotland, 1997.

Pedretti, Carlo. *Raphael: His Life and Work in the Splendors of the Italian Renaissance*. Florence: Giunti, 1989.

Pope-Hennessey, John. *Raphael: The Wrightsman Lectures*. London: Phaidon Press, 1970.

Sonnenberg, Hubertus von. *Raphael: in der Alten Pinakothek: Geschichte und Wiederherstellung des ersten Raphael-Gemaldes in Deutschland und der von König Ludwig I. erworbenen Madonnenbilder*. Munich: Prestel-Verlag, 1983.

Marriage Feast of Cupid and Psyche
 Ceiling Frescoes, Loggia of Psyche
 Villa Farnesina, Rome
 c.1517-18

**RAPHAEL
 and Others**

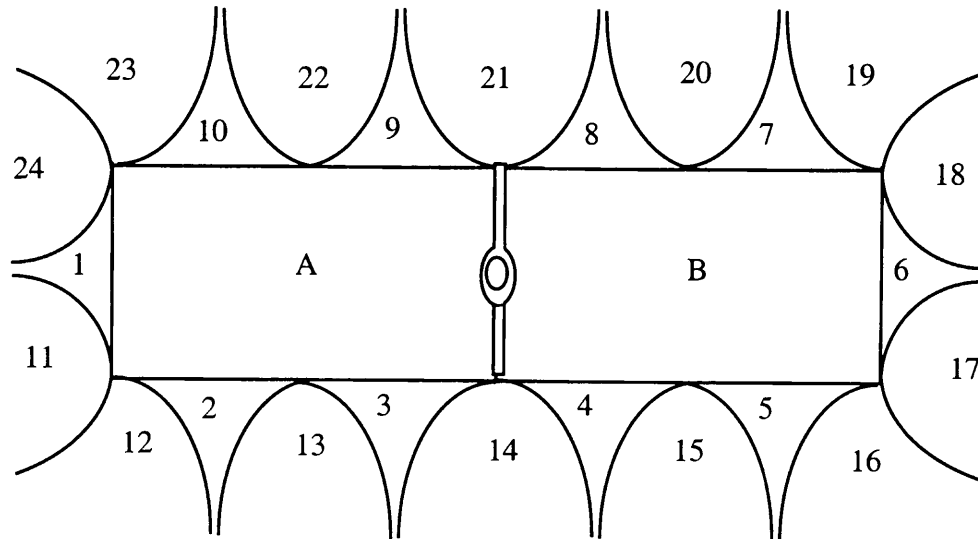

- | | |
|---|---|
| A. Wedding Breakfast | 11. Winged Boy and Eagle |
| B. Council of the Gods | 12. Winged Boy with Trident |
| 1. Venus and Cupid | 13. Winged Boy with Cerberus |
| 2. Cupid and The Three Graces | 14. Winged Boy with Arms |
| 3. Venus, Ceres and Juno | 15. Winged Boy with Griffin |
| 4. Venus on a Golden Chariot | 16. Winged Boy with Caduceus and
Helmet of Mercury |
| 5. Venus and Jove | 17. Winged Boy with Panther |
| 6. Mercury | 18. Winged Boy with Reed Pipe |
| 7. Psyche Giving Venus the Vial of Water
from the Styx | 19. Winged Boy with Shield and Helmet |
| 8. Venus Carried by Cupids and Jove | 20. Winged Boy with Shield and Helmet |
| 9. Cupid and Jove | 21. Winged Boy with Harpy |
| 10. Mercury and Psyche | 22. Winged Boy with Crocodile |
| | 23. Winged Boy, Lion and Sea-horse |
| | 24. Winged Boy with Bow |

Sources: D'Ancona, Paolo. *The Farnesina Frescoes at Rome*. Milan: Edizioni del Milione, 1955.
 Camesasca, Ettore, ed. *All the Frescoes of Raphael*. 2 vols. New York: Hawthorn Books, 1963.
 De Vecchi, Pierluigi. *L'opera completa di Raffaello*. Milan: Rizzoli, 1966.

RAPHAEL

Old Testament Subjects (Raphael's Bible)
Vatican Museums, Vatican City
1518-19

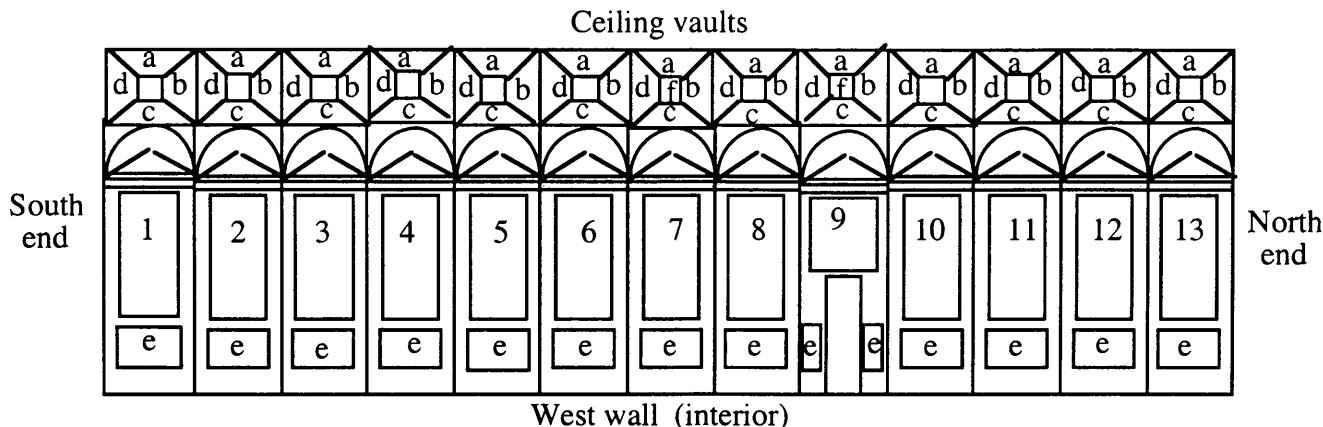

Bay 1: Creation

- a. Division of Light from Dark
- b. Separating Land from Water
- c. Creation of Sun, Moon and Stars
- d. Creation of the Animals
- e. Establishment of the Sabbath

Bay 2: Fall of Man

- a. God Presents Eve to Adam
- b. Temptation of Adam and Eve
- c. Expulsion of Adam and Eve from Paradise
- d. Adam and Eve at Work
- e. Sacrifice of Cain and Abel and Cain Kills Abel

Bay 3: Noah

- a. Noah Supervises the Construction of the Ark
- b. The Flood
- c. Disembarkation from the Ark
- d. Noah's Thanksgiving Sacrifice
- e. God's Covenant with Noah

Bay 4: Abraham

- a. The Meeting of Abraham and Melchizedek
- b. God's Covenant with Abraham
- c. Abraham Kneels before the Three Angels
- d. Lot and His Family Flee Sodom
- e. Sacrifice of Isaac

Bay 5: Isaac

- a. God Renews the Covenant with Isaac
- b. Isaac Embraces Rebekah
- c. Isaac Blesses Jacob
- d. Esau Discovers that Isaac Has Blessed Jacob
- e. Missing

Bay 6: Jacob

- a. Jacob's Dream
- b. Jacob Meets Rachel
- c. Jacob Asks for Rachel as His Wife
- d. Jacob Returns to Canaan
- e. Jacob Struggles with the Angel

Bay 7: Joseph

- a. Joseph Tells His Brothers His Dreams
- b. Joseph is Sold by His Brothers

- c. Joseph Flees from Potiphar's Wife
- d. Joseph Interprets the Pharaoh's Dream
- e. Joseph Addresses His Brothers
- f. Coat of Arms of Leo X (in center)

Bay 8: Moses

- a. Pharaoh's Daughter Discovers the Infant Moses
- b. Moses and the Burning Bush
- c. Moses Parts the Red Sea
- d. Moses Strikes the Rock at Horeb
- e. Gathering of Manna

Bay 9: Moses

- a. Moses Receives the Tablets of the Law
- b. Israelites Worship the Golden Calf
- c. God Speaks to Moses from a Pillar of Cloud
- d. Moses Presents the Tablets of the Law to the Israelites
- e. Destruction of the Sons of Aaron
- f. Coat of arms

Bay 10: Joshua

- a. Joshua Crosses the Jordan
- b. The Walls of Jericho Fall Before Joshua
- c. Joshua Halts the Sun and the Moon
- d. Division of Lands
- e. Joshua Renews the Covenant at Shechem

Bay 11: David

- a. Samuel Anoints David
- b. David Kills Goliath
- c. David and Bathsheba
- d. David's Victory over the Ammonites
- e. David Promises Bathsheba that Solomon Will Rule

Bay 12: Solomon

- a. Zadok Anoints Solomon
- b. Judgment of Solomon
- c. Solomon Builds the Temple
- d. Queen of Sheba Pays Homage to Solomon
- e. Jeroboam Kneels Before Rehoboam

Bay 13: Christ

- a. Adoration of the Shepherds
- b. Adoration of the Magi
- c. Baptism
- d. Last Supper
- e. Resurrection

Source: Davidson, Bernice F. *Raphael's Bible: A study of the Vatican Logge*. University Park: Published for the College Art Association of America by the Pennsylvania State University Press, 1985.

Stanzas
Vatican Museums
Vatican City
1508-17

RAPHAEL

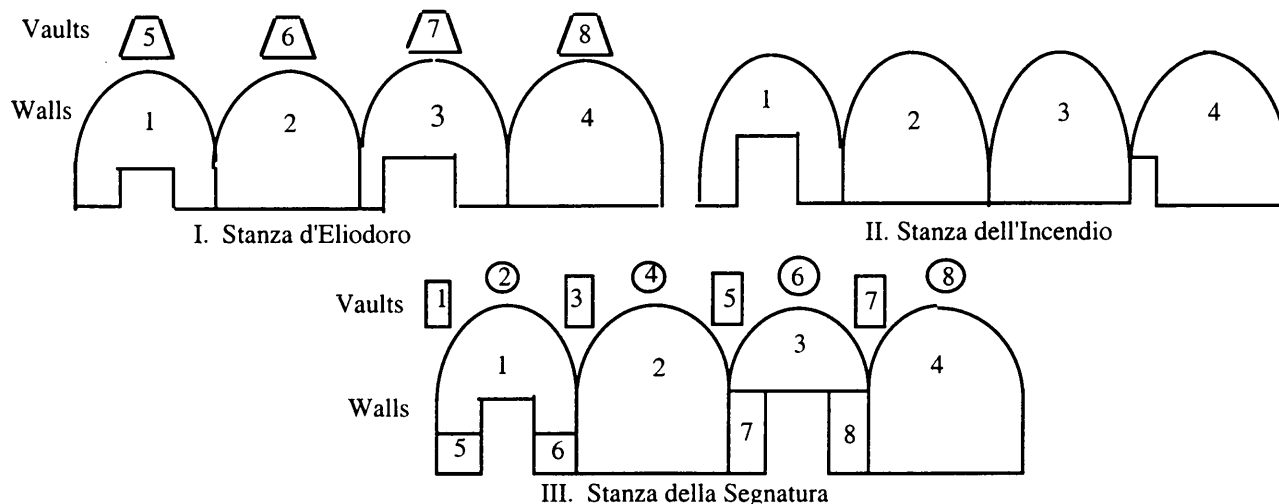

I. Stanza d'Eliodoro (1511-1514)

Walls

1. Liberation of St. Peter
2. Repulse of Attila
3. Mass at Bolsena
4. Expulsion of Heliodorus

Vaults

5. Dream of Jacob
6. God Appears to Noah
7. Sacrifice of Abraham
8. Moses and the Burning Bush

II. Stanza dell'Incendio (1514-1517)

Walls

1. Oath of Leo III
2. Coronation of Charlemagne
3. Fire in the Borgo
4. Battle of Ostia

III. Stanza della Segnatura (1508-1511)

Walls

1. Parnassus
2. School of Athens
3. Three Cardinal Theological Virtues
4. Dispute of the Sacraments
5. Augustus Rescues Virgil's Aeneid from the Fire
6. Alexander the Great Deposits the Homeric Books in the Tomb of Achilles
7. Gregory IX Approving the Decretals
8. Tribonianus Handing Code to Justinian

Vaults

1. Apollo and Marysas
2. Poetry
3. Astronomy
4. Philosophy
5. Adam and Eve
6. Justice
7. Judgement of Solomon
8. Theology

Sources: Camesasca, Ettore, ed. *All the Frescoes of Raphael*. 2 vols. New York: Hawthorn Books, 1963.

De Vecchi, Pierluigi. *L'opera completa di Raffaello*. Milan: Rizzoli, 1966.
Rome e dintorni. 6th ed. Milan: T.C.I., 1965.

**RAPHAEL
and Pupils**

Stufetta of Cardinal Bibbiena
(above Papal Apartment of Pope Leo X)
Vatican City
1516

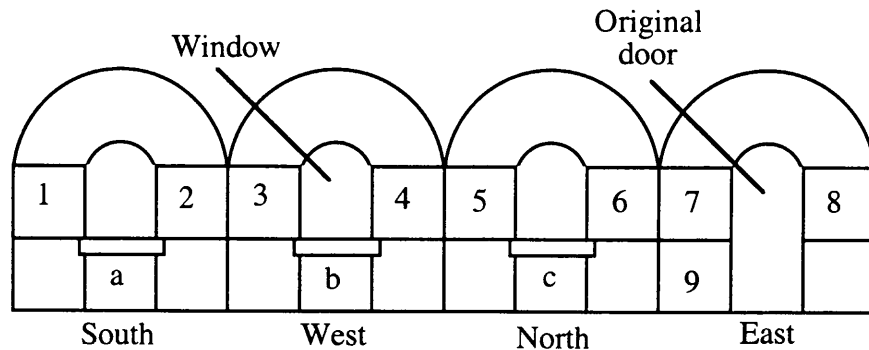

Walls

1. Venus and Cupid Riding on a Dolphin
2. Venus Wounded by Amor
3. Pan and Syrinx
4. Venus Removing Thorn (covered over but documented by an 18th century print by Marcantorio in the Hermitage)
5. Ariadne and Bacchus
6. Myth of Venus (destroyed when new door installed)
7. Vulcan and Minerva
8. Birth of Venus
9. Cupid in a Tub

Marble socles

- a. Gilded Satyr Head Enclosed in a Shell
- b. Cupid Scene
- c. Classical Mask with Water Pouring into a Basin

Ceiling

The Crain and Wild Boar and Grotesques with underpainting of Pompeiian red (not shown in diagram)

Lunettes

Grotesques with River Deities

Sources: Camesasca, Ettore, ed. *All the Frescoes of Raphael*. 2 vols. New York: Hawthorn Books, 1963.

Raffaello in Vaticano: [mostra] Citta del Vaticano, Braccio di Carlo Magno, 16 ottobre 1984-16 gennaio 1985. Milan: Electa, 1984.

Redig de Campos, Deodocio, ed. *Art Treasures of the Vatican: Architecture, Painting, Sculpture*. Englewood Cliffs, New Jersey: Prentice Hall, 1974.

Room of Hercules Frescoes
(Sala d'Ercole)
Palazzo Marucelli, Florence
1706-07

RICCI, SEBASTIANO

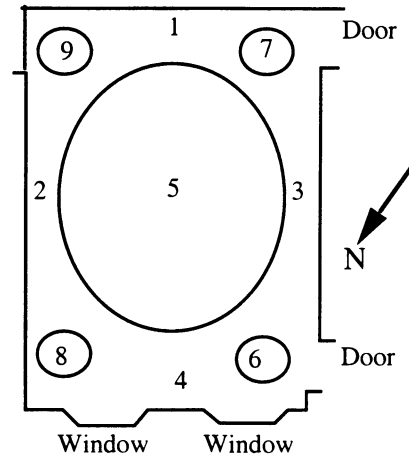

Walls

1. Choice of Hercules
Agriculture (Sickle)
Abundance (Ears of Corn)
(exact position unclear)
2. Hercules and Caeus
3. Hercules Battling with the Centaur Nessus
4. Hercules and Antaeus

Ceiling

5. Apotheosis of Hercules

Medallions at four corners of ceiling (grisaille)

6. Hercules and the Hydra of Lerna
7. Hercules and the Nemean Lion
8. Hercules and Cerberus
9. Hercules in Repose

Overdoor allegorical figures (exact disposition unclear) (treated as white marble carved in high relief)

- Moderation
- Prudence
- Strength
- Justice

Sources: Daniels, Jeffery. *Sebastiano Ricci*. Hove, Sussex: Wayland Publications, 1976.

ROBBIA, LUCA DELLA

Cantoria
(executed for the Cathedral of Florence)
Museo del'Opera dell'Duomo, Florence
1431-38

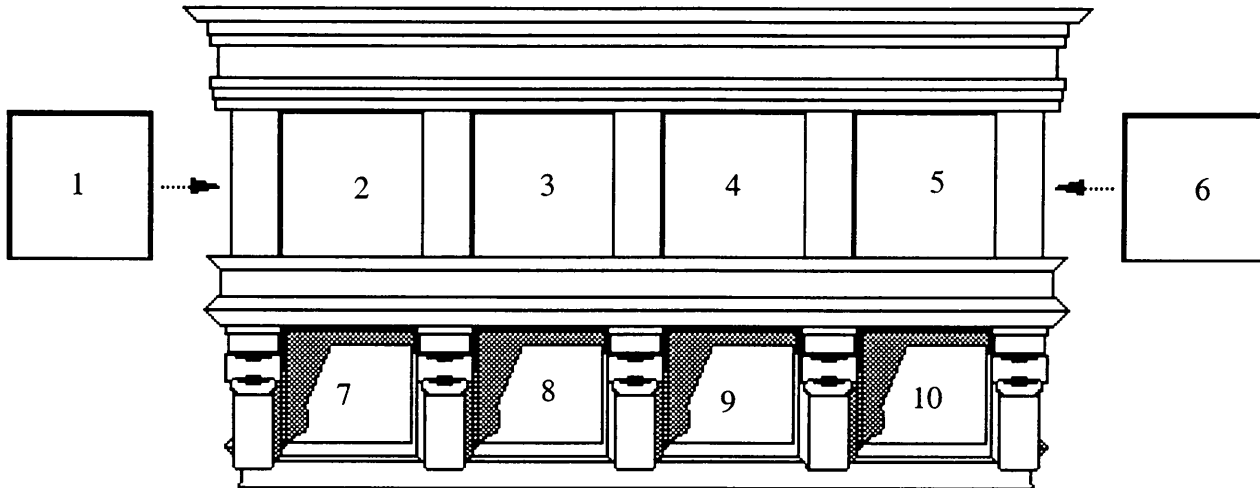

1. Boys Singing from a Book
2. Trumpeters and Dancing Girls
3. Players on the Psaltery
4. Players on the Cithera
5. Drummers
6. Boys Singing from a Scroll
7. Choral Dancers and Singing Girls
8. Players on the Organ, Lute, and Harp
9. Tambourine Players
10. Cymbal Players

Source: Planiscig, Leo. *Luca della Robbia*. Vienna: Verlag Anton Schroll, 1940.

Bronze Doors
San Paolo fuori le
mura

ROME

1	2	3	1	2	3
4	5	6	4	5	6
7	8	9	7	8	9
10	11	12	10	11	12
13	14	15	13	14	15
16	17	18	16	17	18
19	20	21	19	20	21
22	23	24	22	23	24
25	26	27	25	26	27

Left

Right

Left

1. Annunciation
2. Nativity
3. Presentation in the Temple
4. Baptism
5. Transfiguration
6. Entry into Jerusalem
7. Crucifixion
8. Descent from the Cross
9. Resurrection
10. Appearance to Apostles
11. Ascension
12. Pentecost
13. Cross

14. Inscription of Pantaleone
15. Martyrdom of St. Paul
16. Christ, St. Paul and Pantaleone
17. Martyrdom of St. Peter
18. St. Peter
19. Martyrdom of St. Andrew
20. St. Andrew
21. Entombment of St. John the Evangelist
22. St. John the Evangelist
23. Martyrdom of St. Bartholomew
24. St. Bartholomew
25. Eagle

26. St. Thomas
27. Martyrdom of St. Thomas

Right

1. Martyrdom of St. Philip
2. St. Philip
3. Death of St. James
4. St. James
5. Martyrdom of St. Simon
6. St. Simon
7. Entombment of St. Matthew
8. St. Matthew
9. Entombment of St. Luke
10. St. Luke
11. Martyrdom of St. Mark
12. St. Mark

13. Moses
14. Inscription of Pantaleone to St. Paul
15. Cross
16. David
17. Isaiah
18. Hezekiah
19. Jeremiah
20. Ezekiel
21. Daniel
22. Elias
23. Elisha
24. Jonah
25. Abacum
26. Sofonia
27. Eagle

Source: *San Paolo fuori le mura a Roma*. Chiese monumentale d'Italia. Florence: Nardini, 1988.

RUBENS, PETER PAUL

The Triumph of the Eucharist Series
and Related Works
Convent of the Descalzes Reales,
Madrid
(other locations listed below)

1628

Tapestries designed by Rubens, woven by J.Geubels [JG], J.Raes [JR], J.Fobert [JF],
and H.Vervoert [HV].

1. Monstrance Held by Two Cherubs [JG]
2. Angels Playing Music [JG, JF and HV]
3. Angels Playing Music [JR, JF, and HV]
4. Ecclesiastical Hierarchy in Adoration [JR, JF, and HV]
5. Secular Hierarchy in Adoration [JR, JF, and HV]
6. King David Playing the Harp [JG]
7. Abraham and Melchizedek [JG, JR, JF, HV]
8. Gathering of Manna [JR, JF, HV]
9. Elijah and the Angel [JG]
10. Sacrifice of the Old Covenant [JR, JF, and HV]
11. Triumph of the Church [JR]
12. Triumph of Faith [JR, JF, and HV]
13. Triumph of Divine Love [JR, JF, and HV]
14. Four Evangelists [JR, JF, and HV]
15. Defenders of the Eucharist [JR, JF, and HV]
16. Eucharist Overcoming Pagan Sacrifices [JR, JF, and HV]
17. Victory of Truth over Heresy
18. Succession of the Popes [JR and HV]
19. Historiography [JG]
20. Charity Enlightening the World

Bozzetti for the Tapestries

- 1-5. Monstrance Held by Two Cherubs, (1), Angels Playing Music, (2), Angels Playing Music, (3), Ecclesiastical Hierarchy in Adoration, (4), Secular Hierarchy in Adoration, (5), Chicago Art Institute (all on same board)
6. King David Playing the Harp (lost*)
7. Abraham and Melchizedek, Cambridge, Fitzwilliam Museum
8. Gathering of the Manna, Bayonne, Musee Bonnat
9. Elijah and the Angel, Bayonne, Musee Bonnat
10. Sacrifice of the Old Covenant (lost)
11. Triumph of the Church, Cambridge Fitzwilliam Museum
- 12a. Triumph of the Faith, Cambridge, Fitzwilliam Museum
- 12b. Triumph of the Faith, Sweden, Private Collection
13. Triumph of Divine Love, Cambridge, Fitzwilliam Museum
14. Four Evangelists, Cambridge, Fitzwilliam Museum
15. Defenders of the Eucharist, Cambridge, Fitzwilliam Museum
16. Eucharist Overcoming Pagan Sacrifices (lost)
17. Victory of Truth over Heresy, Cambridge, Fitzwilliam Museum
18. Succession of the Popes (lost)
19. Historiography, Tournai, Musee des Beaux Arts
20. Charity Enlightening the World (lost)
21. Triumph of Hope, NY, Richard L. Feigen and Co.

Modelli for the Tapestries

1. Monstrance Held by Two Cherubs (lost)
- 2-3. Angels Playing Music, Potsdam, Sanssouci Bildergalerie (joined)
4. Ecclesiastical Hierarchy in Adoration, Louisville, KY, Speed Art Museum

The Triumph of the Eucharist Series
and Related Works
Convent of the Descalzes Reales,
Madrid
(other locations listed below)
1628

RUBENS, PETER PAUL

Modelli for the Tapestries (con't)

5. Secular Hierarchy in Adoration (lost)
6. King David Playing the Harp, Merion Station, PA, Barnes Foundation
- 7a. Abraham and Melchizedek, Madrid, Prado
- 7b. Abraham and Melchizedek, Washington, DC, National Gallery of Art
8. Gathering of Manna, Los Angeles, CA, Los Angeles County Museum of Art
9. Elijah and the Angel, Bayonne, Musee Bonnat
10. Sacrifice of the Old Covenant, Topsfield, MA, Collection of William A. Coolidge
11. Triumph of the Church, Madrid, Prado
12. Triumph of the Faith, Brussels, Musee Royaux des Beaux-Arts de Belgique
13. Triumph of Divine Love, Madrid, Prado
14. Four Evangelists, Sudeley Castle, Gloucestershire, Collection of Mrs. Dent-Brocklehurst
15. Eucharist Overcoming Pagan Sacrifices, Madrid, Prado
16. Victory of Truth over Heresy, Madrid, Prado
17. Succession of the Popes, San Diego, CA, Fine Arts Gallery of San Diego
18. Historiography (whereabout unknown)
19. Charity Enlightening the World, Amherst, MA, Amherst College, Meade Art Museum

Cartoons for the Tapestries

1. Monstrance Held by Two Cherubs (lost)
2. Angels Playing Music (lost)
3. Angels Playing Music (lost)
4. Ecclesiastical Hierarchy in Adoration (lost)
5. Secular Hierarchy in Adoration (lost)
6. King David Playing the Harp (lost)
7. Abraham and Melchizedek, Sarasota, FL, John and Mable Ringling Museum of Art
8. Gathering of Manna, Sarasota, FL, John and Mable Ringling Museum of Art
9. Elijah and the Angel, Valenciennes, Musee des Beaux-Arts
10. Sacrifice of the Old Covenant (destroyed in Brussels Palace fire)
11. Triumph of the Church (destroyed in Brussels Palace fire)
12. Triumph of Faith, Valenciennes, Musee des Beaux-Arts
13. Triumph of Divine Love, London, Ross Galleries
14. Four Evangelists, Sarasota, FL, John and Mable Ringling Museum of Art
15. Defenders of the Eucharist, Sarasota, FL, John and Mable Ringling Museum of Art
16. Eucharist Overcoming Pagan Sacrifice (destroyed in Brussels Palace fire)
17. Victory of Truth Over Heresy (destroyed in Brussels Palace fire)
18. Succession of the Popes (lost)
19. Historiography (lost)
20. Charity Enlightening the World (lost)

Additional Works

13. Female Nudes and Charity with Children, drawing, St. Petersburg, Hermitage
 14. Defenders of the Eucharist, oil on panel, Zurich, Collection of Mrs. H. Anda-Buhrle
- (All works designated as "lost" De Poorter lists as whereabouts unknown, presumably lost.)

Source: Poorter, Nora de. *The Eucharist series*, 2 vols. London: Harvey Miller; Philadelphia: Heyden and Son, 1978.

SCHIAVONE, GIORGIO

Polyptych in Ten Panels
(for St. Niccolo, Padua?)
National Gallery, London
probably 1460s

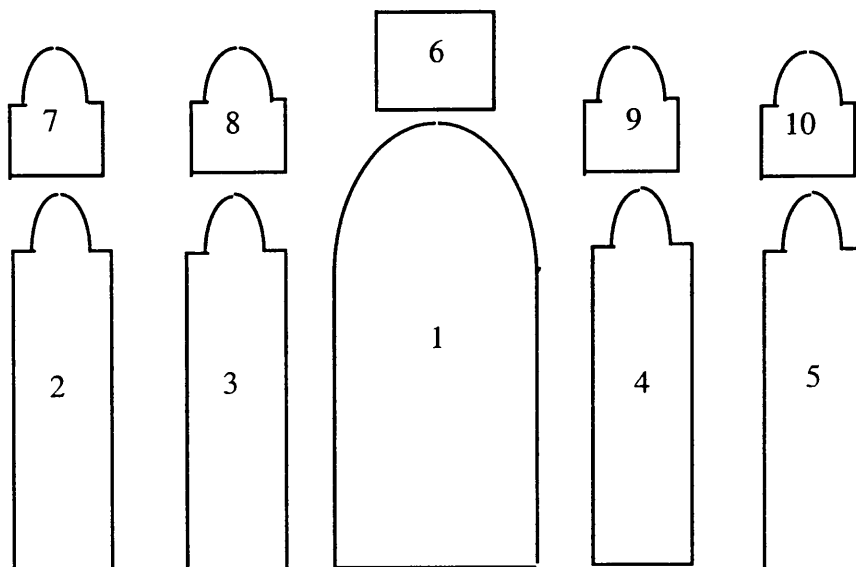

- | | |
|-------------------------------|--------------------------|
| 1. Virgin and Child Enthroned | 6. Pieta |
| 2. St. Bernardino of Siena | 7. St. Jerome |
| 3. St. Anthony of Padua | 8. St. Catherine |
| 4. St. Peter Martyr | 9. St. Sebastian |
| 5. St. John the Baptist | 10. Unknown Female Saint |

Source: *Microsoft Art Gallery: The Collection of the National Gallery, London*. Redmond, Washington: Microsoft Corporation, 1993.

San Brizio Chapel Frescoes
 (Chapel of the Madonna of San
 Brizio)
 Orvieto
 1447-49 and 1499-1503

**SIGNORELLI, LUCA
 and FRA ANGELICO**

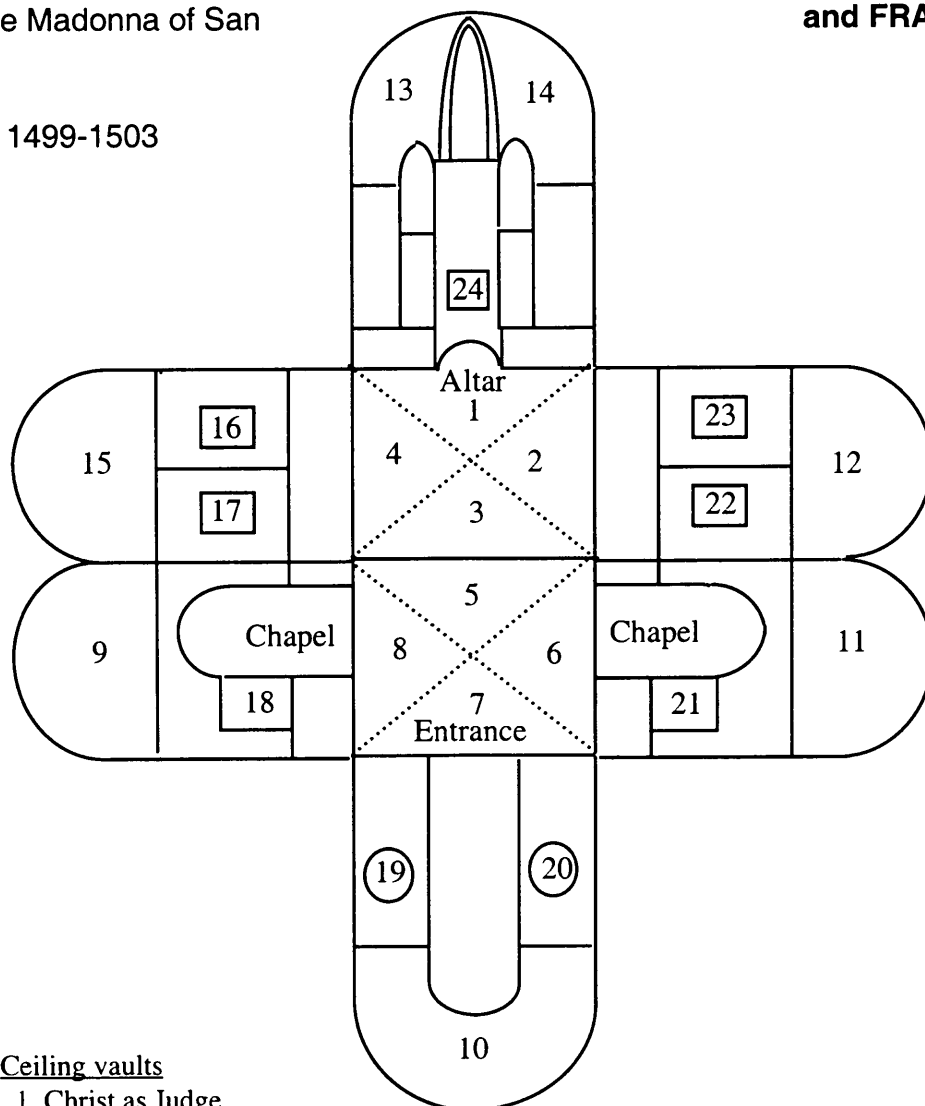

Ceiling vaults

1. Christ as Judge
 2. Virgin and Apostles
 3. Angels with Instruments of the Passion
 4. St. John the Baptist and Prophets
- Prophets
5. Martyrs
 6. Church Fathers
 7. Virgins
 8. Old Testament Patriarchs

Lunettes

9. Sermon and Deeds of the Antichrist
10. End of the World
11. Resurrection of the Flesh
12. Damned in Hell
13. Blessed in Heaven
14. Entrance into Hell
15. Blessed in Heaven

16. Statius
17. Dante
18. Sallust
19. Young Man in a Turban
20. Destroyed
21. Tibullus
22. Ovid
23. Claudian
24. Virgil

Sources: Riess, Jonathan B. *Luca Signorelli: The San Brizio Chapel, Orvieto*. New York: George Braziller, 1995.

Roettgen, Steffi. *Italian Frescoes. Vol.2, The Flowering of the Renaissance, 1470-1510*. New York, London and Paris: Abbeville Press, 1997.

San Juan, Rose Marie. "The Illustrious Poets in Signorelli's Frescoes for the Cappella Nuova of Orvieto Cathedral." *Journal of the Warburg and Courtauld Institutes*, 52 (1989), 71-84.

STOSS, VEIT

Bamberg Altarpiece
Cathedral, Bamberg
1520-23

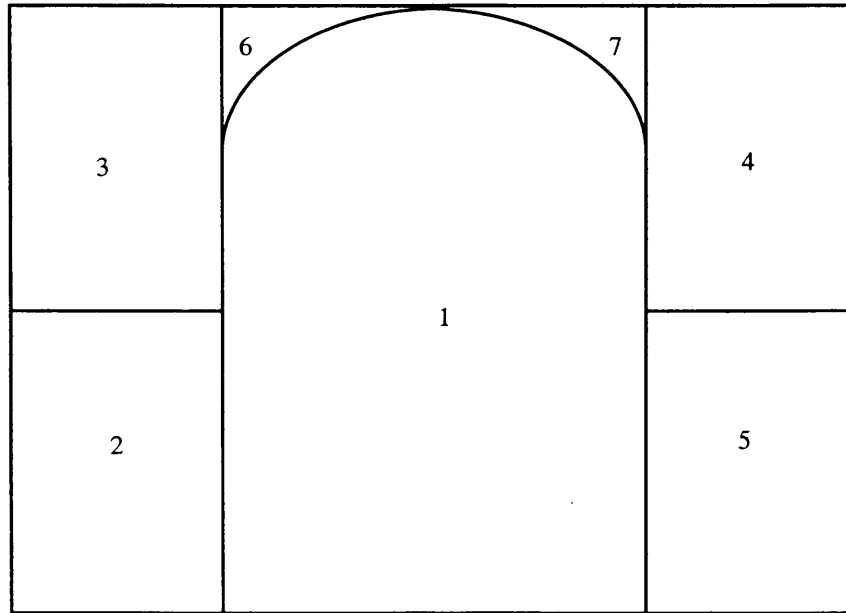

1. Nativity
2. Adoration of the Magi
3. Flight into Egypt
4. Birth of the Virgin
5. Presentation of the Virgin
6. Angel
7. Angel

Sources: Keller, Harald. *Veit Stoss: Der Bamberger Marien-Altar*. Stuttgart: Philipp Reclam, 1959
Lutze, Eberhard. *Veit Stoss*. Munich: Deutscher Kunstverlag, 1968.
Sello, Gottfried. *Veit Stoss*. Munich: Hirmer Verlag, 1988.

Krakow Altarpiece
 Church of St. Mary, Krakow
 1477-89

STOSS, VEIT

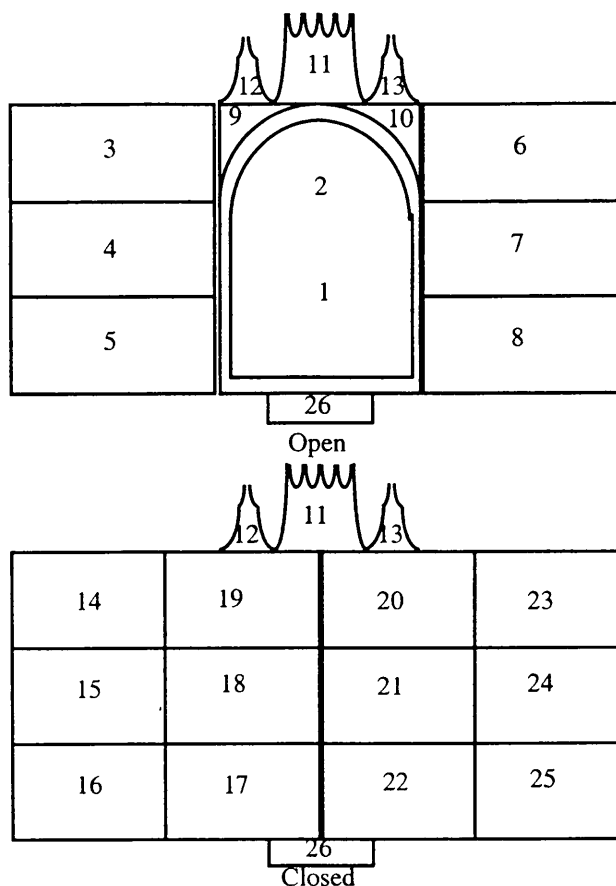

Open

1. Death of the Virgin
2. Assumption of the Virgin
3. Annunciation
4. Nativity
5. Adoration of the Magi
6. Resurrection
7. Ascension
8. Pentecost
9. Sts. Gregory and Jerome
10. Sts. Augustine and Ambrose
11. Coronation of the Virgin
12. St. Adelbert
13. St. Stansilas

Closed

14. Meeting at the Golden Gate
15. Birth of the Virgin
16. Presentation of the Virgin
17. Presentation in the Temple
18. Christ among the Doctors
19. Betrayal
20. Crucifixion
21. Deposition
22. Entombment
23. Descent into Limbo
24. Three Maries at the Tomb
25. Noli me tangere
26. Tree of Jesse

Sources: Chrzanowski, Tadeusz. *Krakauer Marienaltar*, Veit Stoss. Warsaw: Interpress, 1985.
 Sello, Gottfried. *Veit Stoss*. Munich: Hirmer Verlag, 1988.
 Snyder, James. *Northern Renaissance Art: Painting, Sculpture, the Graphic Arts from 1350-1575*. New York: Harry N. Abrams, 1985.

**TIEPOLO, GIOVANNI
BATTISTA**

Ceiling Frescoes
Palazzo Clerici, Milan
1740

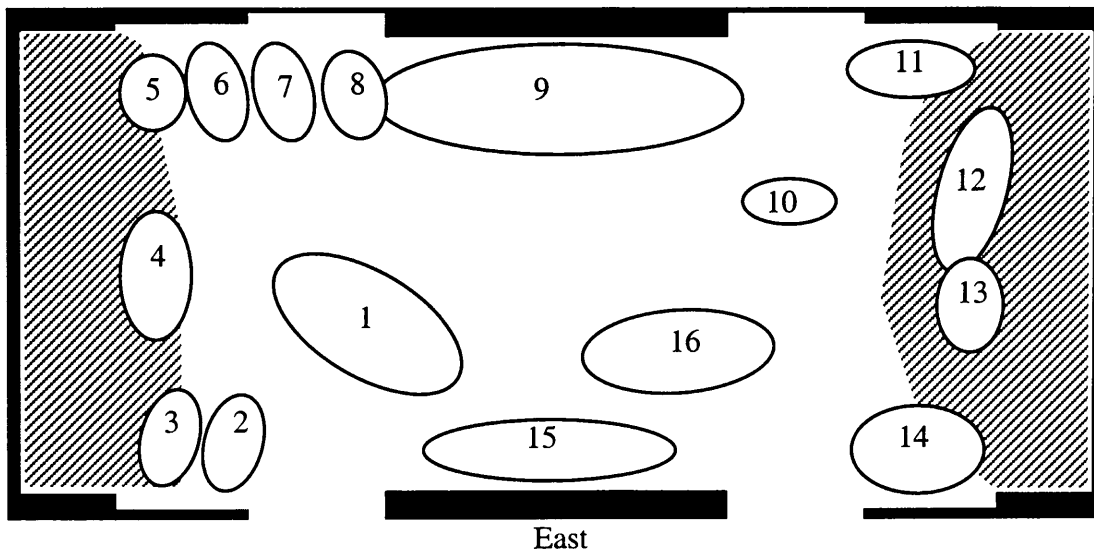

1. Rape of Venus
2. River Gods
3. River God Group: God, Naiad, and Fisherman
4. River God Group: God and Naiad
5. Myth of Proserpine
6. Demeter and Flora
7. Myth of Dionysus
8. Allegory of Asia
9. Allegory of America
10. Hermes
11. Allegory of the Sea
12. Allegory of Art
13. Allegory of Music
14. Allegory of Africa
15. Allegory of Europe
16. Sun's Chariot

Sources: Ancona, Paolo d'. *Tiepolo in Milan: The Palazzo Clerici Frescoes*. Milan: Edizioni del Milione, 1956.

Morassi, Antonio. *A Complete Catalogue of the Paintings of G. B. Tiepolo*. London: Phaidon Press, 1962.

Pallucchini, Anna. *L'opera completa di Giambattista Tiepolo*. Milan: Rizzoli, 1968.

Lower Walls
Sistine Chapel, Vatican City
c.1479-82

VATICAN CITY
(Artists listed below)

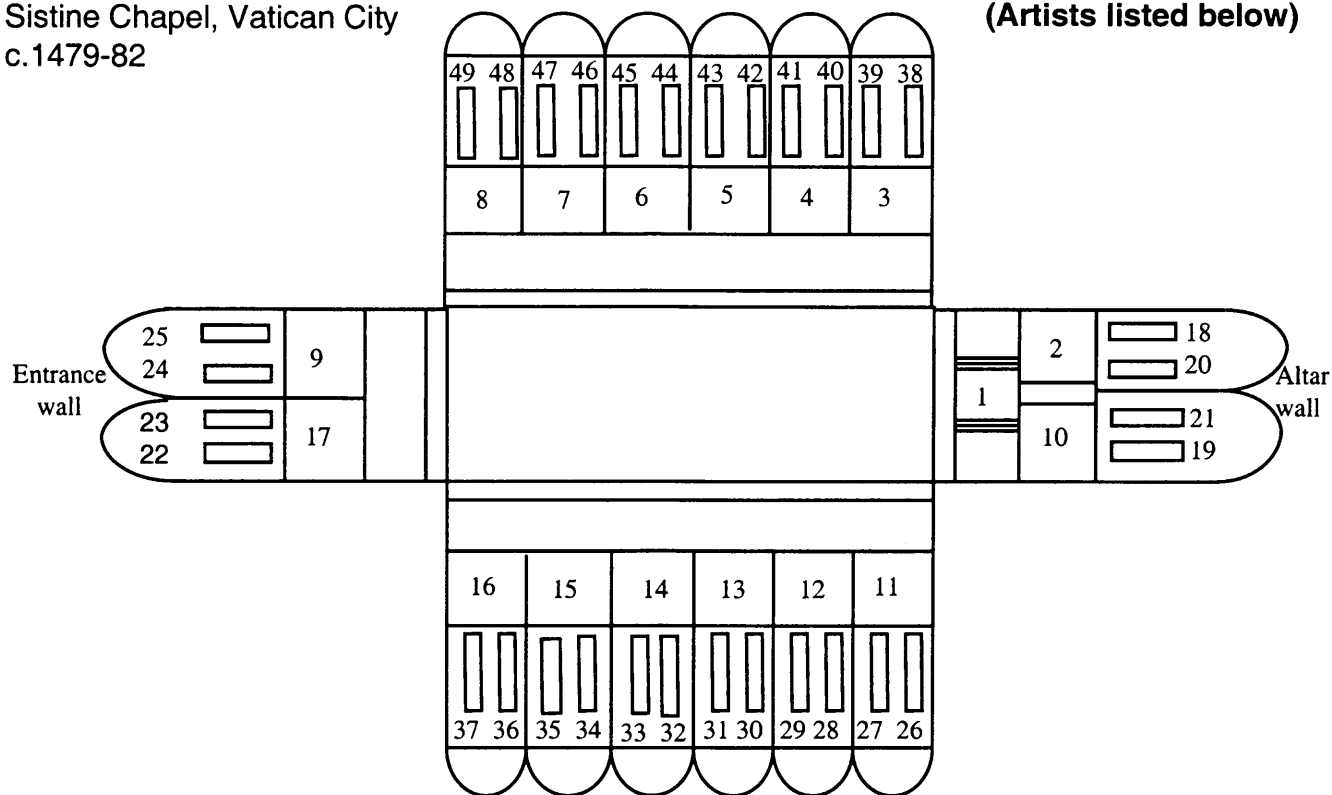

- | | | |
|---|--|----------------|
| 1. Perugino. Assumption | 14. Rosselli. Sermon on the Mount and Healing of the Leper | 30. Soter |
| 2. Perugino. Finding of Moses | 15. Perugino. Christ Giving the Keys to St. Peter | 31. Victor I |
| 3. Perugino. Journey into Egypt and Circumcision of Moses' Son Eliezer | 16. Rosselli. Last Supper | 32. Calixtus I |
| 4. Botticelli. Trials and Calling of Moses | 17. Hendrick van den Broeck (originally Ghirlandaio). Resurrection and Ascension | 33. Pontian |
| 5. Rosselli. Crossing of the Red Sea | 18. Linus (?) | 34. Fabian |
| 6. Rosselli. Giving of the Tables of the Law and Adoration of the Golden Calf | 19. Cletus | 35. Lucius I |
| 7. Botticelli. Punishment of Korah and Stoning of Moses (destroyed) | 20. St. Paul | 36. Sixtus II |
| 8. Signorelli. Last Episodes of the Life of Moses | 21. St. Peter | 37. Felix I |
| 9. Matteo da Lecce (originally Signorelli). Contest for the Body of Moses | 22. Caius | 38. Clement |
| 10. Perugino. Nativity | 23. Ertychianus | 39. Evaristus |
| 11. Perugino. Baptism; Christ Preaching and Sermon of St. John the Baptist | 24. Marcellinus | 40. Sixtus I |
| 12. Botticelli. Temptations of Christ | 25. Marcellus I | 41. Hyginus |
| 13. Ghirlandaio. Calling of the Apostles | 26. Anacletus | 42. Ancicetus |
| | 27. Alexander I | 43. Eleutheius |
| | 28. Telesporus | 44. Zephyrinus |
| | 29. Pius I | 45. Urban I |
| | | 46. Anterus |
| | | 47. Cornelius |
| | | 48. Stephan I |
| | | 49. Dionysius |

Sources: Ettliger, Leopoldo D. *The Sistine Chapel before Michelangelo: Religious Imagery and Papal Primacy*. Oxford: Clarendon Press, 1965.

Roettgen, Steffi. *Italian Frescoes*. Vol.1, *The Early Renaissance, 1400-1470*; Vol.2, *The Flowering of the Renaissance, 1470-1510*. New York, London and Paris: Abbeville Press, 1995-96.

**WEYDEN, ROGIER VAN DER
and Workshop**

Mary Altarpiece (Granada Altarpiece)
(panels 1 and 2) Capilla Real, Granada,
(panel 3) Metropolitan Museum of Art, New York City,
and its copy, Altarpiece of the Virgin
Staatliche Museen, Berlin
c.1440-44

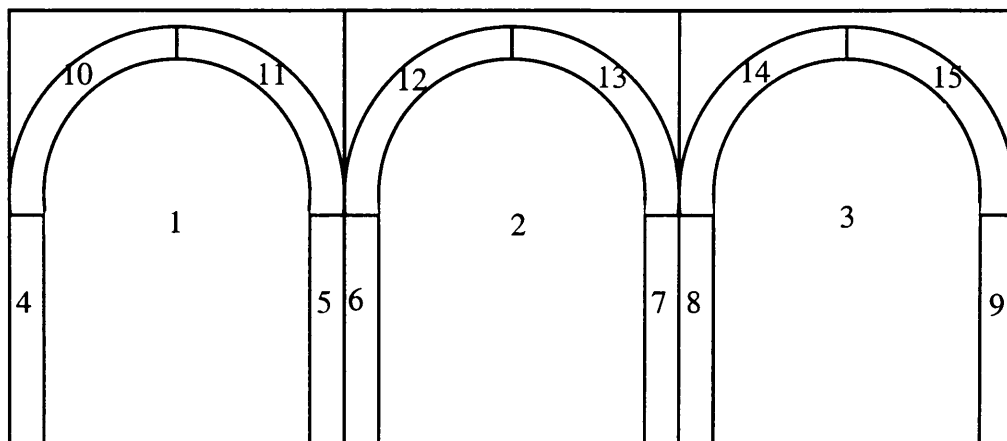

Panels

1. Holy Family with Angel
2. Pieta with Angel
3. The Resurrected Christ Appears to Mary with Angel
4. St. Peter
5. St. Luke
6. St. John the Evangelist
7. St. Matthew
8. St. Mark
9. St. Paul

Sculpted archivolts:

Infancy

10. Nativity; Visitation; and Annunciation
11. Presentation in the Temple; Adoration of the Magi;
and Adoration of the Shepherds

Passion

12. Road to Calvary; Virgin Told of Christ's Arrest;
and Christ Taking Leave of His Mother
13. Entombment; Crucifixion; and Raising of the Cross

Post-Passion

14. Pentecost; Ascension, and the Virgin and Three Maries
15. Coronation of the Virgin; Death of the Virgin; and
Annunciation of the Virgin's Death

Sources: Campbell, Lorne. *Van der Weyden*. New York: Harper and Row, 1980.
Cuttler, Charles D. *Northern Painting from Pucelle to Bruegel: Fourteenth, Fifteenth,
and Sixteenth Centuries*. New York: Holt, Rinehart, and Winston, 1968.
Davies, Martin. *Rogier van der Weyden: An Essay, with a Critical Catalogue of Paint-
ings Assigned to Him and to Robert Campin*. London: Phaidon Press, 1972.

Triptych of the Last Judgement
(Beaune Altarpiece)
Musée de l'Hotel Dieu, Beaune
after 1443
before 1451

WEYDEN, ROGER VAN DER

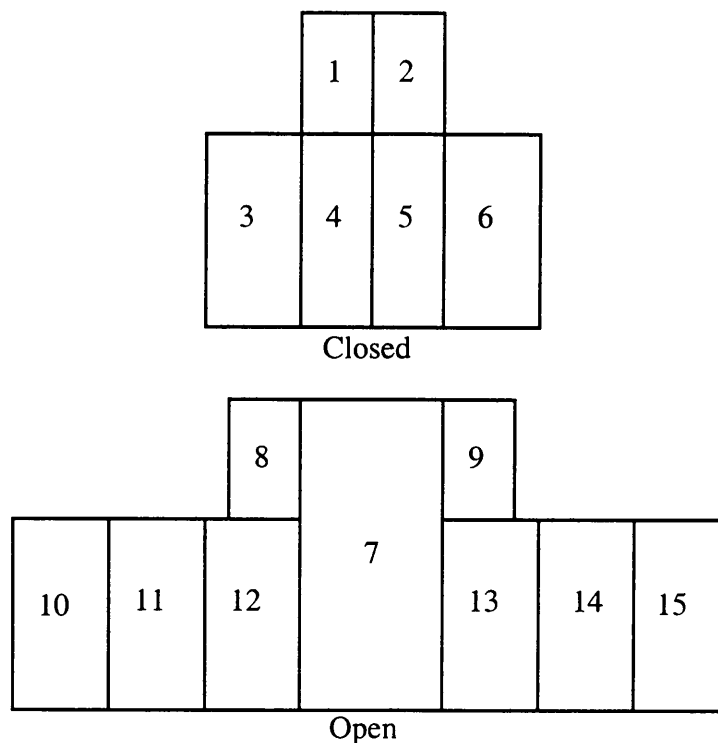

Closed

1. Angel Gabriel (grisaille)
2. Virgin of the Annunciation (grisaille)
3. Chancellor Nicholas Rolin
4. St. Sebastian (grisaille)
5. St. Anthony (grisaille)
6. Guigonne de Salins (third wife of Chancellor Nicolas Rolin)

Open

7. Christ in Judgement
8. Angels with Instruments of the Passion
9. Angels with Instruments of the Passion
10. Entrance to Paradise
11. St. Peter, three other Apostles and four Saints (the Resurrected)
12. Virgin and two Apostles (below, the Saved)
13. St. John the Baptist and two Apostles (below, the Damned)
14. St. Paul, three Apostles and three Saints (the Damned)
15. Hell

Sources: Campbell, Lorne. *Van der Weyden*. New York: Harper and Row, 1980.

Davies, Martin. *Rogier van der Weyden: An Essay, with a Critical Catalogue of Paintings Assigned to Him and to Robert Campin*. London: Phaidon Press, 1972.

BIBLIOGRAPHY

- Acidini Luchinat, Cristina. *Benozzo Gozzoli*. Florence: Scala, 1994.
- _____, ed. *The Chapel of the Magi: Benozzo Gozzoli's Frescoes in the Palazzo Medici-Riccardi Florence*. London and New York: Thames and Hudson, 1994.
- Amaducci, Alberto. *La cappella di palazzo medici*. Florence: Arsuna, 1977.
- Ancona, Paolo d'. *The Farnesina Frescoes at Rome*. Milan: Edizioni del Milione, 1955.
- _____. *Tiepolo in Milan: The Palazzo Clerici Frescoes*. Milan: Edizioni del Milione, 1956.
- Arndt, Karl. *Hugo van der Goes: Der Portinari-Altar*. Stuttgart: Philip Reclam, 1965.
- Ayrton, Michael. *Giovanni Pisano: Sculptor*. New York: Weybright and Talley, Inc., 1969.
- Baccheschi, Edi. *The Complete Paintings of Giotto*. New York: Harry N. Abrams, 1966; London: Weidenfeld and Nicolson, 1969.
- Baldini, Umberto. *Beato Angelico*. Florence: Edizioni d'arte Il Fiorino, 1986.
- _____. *L'opera completa dell'Angelico*. Milan: Rizzoli, 1970.
- Bandera Bistoletti, Sandrina. *Il polittico di San Luca di Andrea Mantegna (1453-1454): in occasione del suo restauro*. Florence: Cantini, 1989.
- Bardazzi, Silvestro, and Eugenio Castellani. *La villa medicea di Poggio a Caiano*. 2 vols. Prato: Edizioni del Palazzo, 1981.
- Bargellini, Piero. *The Medici Palace and the Frescoes of Benozzo Gozzoli*. Rome: Lorenzo del Turco, 1965.
- Baumgarten, Fritz. *Der Freiburger Hochaltar: kunstgeschichtlich gewurdigt*. Reprint ed. Nendeln, Lichtenstein: Kraus, 1979.
- Bax, Dirk. *Hieronymus Bosch and Lucas Cranach: Two Last Judgement Triptychs: Description and Exposition*. Amsterdam and New York: North-Holland Pub. Co., 1983.
- Bellosi, Luciano. *Giotto*. Florence: Scala, 1981.
- _____. *Pietro Lorenzetti ad Assisi*. Assisi: Edizioni DACA, 1982.
- Bennett, Bonnie A., and David G. Wilkins. *Donatello*. Oxford: Phaidon Press, 1984.
- Bertelli, Carlo. *Piero della Francesca*. New Haven: Yale University Press, 1992.
- Bianconi, Piero. *All the Paintings of Lorenzo Lotto*. 2 vols. Translated by Paul Colacicchi. New York: Hawthorne Books, Inc., 1963.
- Blum, Shirley Neilsen. *Early Netherlandish Triptychs: A Study in Patronage*. Berkeley and Los Angeles: University of California Press, 1969.
- Blunt, Anthony. *Nicolas Poussin*. 2 vols. New York: Bollingen Foundation, 1967.
- _____. *The Paintings of Nicolas Poussin: A Critical Catalogue*. London: Phaidon Press, 1966.
- Boeckler, Albert. *Die Bronzetauren des Bonanus von Pisa und des Barisanus von Trani*. Berlin: Deutscher Verein fur Kunstwissenschaft, 1953.
- Borsook, Eve. *The Companion Guide to Florence*. 3rd ed. London: Collins, 1974.
- _____. *The Mural Painters of Tuscany: From Cimabue to Andrea del Sarto*. 2nd ed. Oxford: Clarendon Press, 1980.
- Borsook, Eve, and Johannes Offerhaus. *Francesco Sassetti and Ghirlandaio at Santa Trinita, Florence: History and Legend in a Renaissance Chapel*. Doornspijk, Holland: Davaco Publishers, 1981.

- Brans, Jan V. L. *Hieronymus Bosch (El Bosco) en el Prado y en el Escorial*. Barcelona: Ediciones Omega, 1948.
- Brucher, Gunter. *Farbe und Licht in Albrecht Altdorfers Sebastiansaltar in St. Florian*. Graz: Akademische Druck-u. Verlagsanstalt, 1978.
- Busignani, Alberto, and Raffaello Bencini. *Le chiese di Firenze*. Vol.1, *Quartiere di Santo Spirito*. Florence: Sansoni, 1974.
- Camesasca, Ettore, ed. *All the Frescoes of Raphael*. 2 vols. Translated by Paul Colacicchi. New York: Hawthorn Books, 1963.
- Campbell, Lorne. *Van der Weyden*. New York: Harper and Row, 1980.
- Carli, Enzo. *Giovanni Pisano*. Pisa: Pacini, 1977.
- _____. *Giovanni Pisano: Il Pulpito di Pistoia*. Milan: G. Mondadori and Associates, 1986.
- _____. *Sculpture of Italy*. Milan: Electa, 1967.
- Casazza, Ornella. *Masaccio and the Brancacci Chapel*. Florence: Scala, 1990.
- Cecchi, Emilio. *Pietro Lorenzetti*. Milan: Fratelli Treves, 1930.
- Christiansen, Keith. *Andrea Mantegna, Padua and Mantua*. New York: George Braziller, 1994.
- _____. *Gentile da Fabriano*. Ithaca, New York: Cornell University Press, 1982.
- Chrzanowski, Tadeusz. *Krakauer Marienaltar, Veit Stoss*. Warsaw: Interpress, 1985.
- Cole, Alison. *Virtue and Magnificence: Art of the Italian Renaissance Courts*. New York: Harry N. Abrams, 1995.
- Cole, Bruce. *Agnolo Gaddi*. Oxford: Clarendon Press, 1977.
- _____. *Piero della Francesca: Tradition and Innovation in Renaissance Art*. New York: Icon Editions, 1991.
- Collareta, Marco, ed. *Donatello in Toscana: itinerario*. Florence: S.P.E.S., 1985.
- Concise Catalogue of Paintings*. Edinburgh: Trustees of the National Galleries of Scotland, 1997.
- Cornini, Guido, et al, ed. *Raphael in the Apartments of Julius II and Leo X: Papal Monuments, Museums, Galleries*. Milan: Electa, c.1993.
- Cottier, Jean-Pierre. *"Le Vele" nella basilica inferiore di Assisi: saggio e analisi*. Florence: Edam, 1981.
- Cuttler, Charles D. *Northern Painting from Pucelle to Bruegel: Fourteenth, Fifteenth, and Sixteenth Centuries*. New York: Holt, Rinehart, and Winston, 1968.
- D'Ancona, Paolo. *The Farnesina Frescoes at Rome*. Milan: Edizioni del Milione, 1955.
- _____. *Tiepolo in Milan: The Palazzo Clerici Frescoes*. Milan: Edizioni del Milione, 1956.
- Daniels, Jeffery. *L'opera completa di Sebastiano Ricci*. Milan: Rizzoli, 1976.
- _____. *Sebastiano Ricci*. Hove, Sussex: Wayland Publications, 1976.
- Davidson, Bernice F. *Raphael's Bible: A Study of the Vatican Logge*. University Park: Published for the College Art Association of America by the Pennsylvania State University Press, 1985.
- Davies, Gerald Stanley. *Ghirlandaio*. New York: Scribner's, 1909.
- Davies, Martin. *The Early Italian Schools: Before 1400*. Rev. ed. by Dillian Gordon. London: National Gallery Publications, 1988.
- _____. *Rogier van der Weyden: An Essay, with a Critical Catalogue of Paintings Assigned to Him and to Robert Campin*. London: Phaidon Press, 1972.

- Delogu Ventroni, Sebastiana. *Barna da Siena*. Pisa: Giardini, 1972.
- Destree, Jules. *Roger de la Pasture van der Weyden*. 2 vols. Paris and Brussels, Les Editions G. van Oest, 1930.
- Deuchler, Florens. *Duccio*. Milan: Electa, 1984.
- De Vecchi, Pierluigi. *L'opera completa di Raffaello*. Milan: Rizzoli, 1966.
- DeWald, Ernest T. *Pietro Lorenzetti*. Cambridge: Harvard University Press, 1930.
- Domenico Beccafumi e il suo tempo*. Milan: Electa, 1990.
- Dunkerton, Jill, et al. *Giotto to Durer: Early Renaissance Painting in the National Gallery*. New Haven: Yale University Press in association with National Gallery Publications, 1991.
- Dussler, Luitpold. *Raphael: A Critical Catalogue of his Pictures, Wall-Paintings and Tapestries*. London and New York: Phaidon Press, 1971.
- Eisenberg, Marvin. *Lorenzo Monaco*. Princeton, New Jersey: Princeton University Press, 1989.
- Eisler, Colin T. *The Genius of Jacopo Bellini: The Complete Paintings and Drawings*. New York: Harry N. Abrams, 1989.
- Ettlinger, Leopold D. *The Sistine Chapel before Michelangelo: Religious Imagery and Papal Primacy*. Oxford: Clarendon Press, 1965.
- Faggin, George T. *L'opera completa di Memling*. Milan: Rizzoli, 1969.
- Finn, David, et al. *The Florence Baptistery Doors*. New York: Viking Press, 1980.
- Fiocco, Giuseppe. *L'arte di Andrea Mantegna*. Venice: Neeri Pozza Editore, 1959.
- _____. *The Frescoes of Mantegna in the Eremitani Church, Padua*. 2nd ed. Oxford: Phaidon Press, 1978.
- Friedlander, Max J. *Early Netherlandish Painting*. Vol. 3, *Dieric Bouts and Joos van Gent*. Vol. 6, Pt. 1, Hans Memlinc and Gerard David. Leiden: A.W. Sijthoff, 1968.
- Frugoni, Chiara. *Pietro and Ambrogio Lorenzetti*. Florence: Scala, 1988.
- Garavaglia, Niny. *L'opera completa del Mantegna*. Milan: Rizzoli, 1967.
- Gardner von Teuffel, Christa. "Masaccio and the Pisa Altarpiece: A New Approach." *Jahrbuch der Berliner Museen* 19 (1977): 23-68.
- Goffen, Rona. *Giovanni Bellini*. New Haven and London: Yale University Press, 1989.
- Goldscheider, Ludwig. *Donatello*. Phaidon ed. New York: Oxford University Press, 1941.
- Gombrich, Ernst, et al. *Giulio Romano*. 2 vols. Milan: Electa, 1989.
- Grosshans, Rainald. *Maerten van Heemskerck: Die Gemalde*. Berlin: Horst Boettcher, 1980.
- Hartt, Frederick. *Giulio Romano*. 2 vols. New Haven: Yale University Press, 1958.
- Hibbard, Howard. *Michelangelo*. New York: Harper and Row, 1974.
- Honour, Hugh, and John Fleming. *The Visual Arts: A History*. 3rd ed. New York: Harry N. Abrams, 1991.
- Important Old Master Pictures, London, Friday, 24 May 1991*. London: Christie Manson & Woods International, Inc., 1991.
- Janson, H.W. *The Sculpture of Donatello*. 2 vols. Princeton, N.J.: Princeton University Press, 1963.
- Joannides, Paul. *Masaccio and Masolino: A Complete Catalogue*. London: Phaidon Press, 1993.
- Jones, Roger, and Nicholas Penny. *Raphael*. New Haven: Yale University Press, 1983.
- Keller, Harald. *Giovanni Pisano*. Vienna: Verlag Anton Schroll, 1942.

- _____. *Veit Stoss: Der Bamberger Marien-Altar*. Stuttgart: Philip Reclam, 1959.
- Koller, Manfred, and Norbert Wibiral. *Der Pacher-Altar in St. Wolfgang: Untersuchung, Konservierung und Restaurierung, 1969-1976*. Vienna: Hermann Bohlau, 1981.
- Krautheimer, Richard, and Trude Krautheimer-Hess. *Lorenzo Ghiberti*. Princeton, New Jersey: Princeton University Press, 1982.
- Ladis, Andrew. *Taddeo Gaddi: Critical Reappraisal and Catalogue Raisonne*. Columbia and London: University of Missouri Press, 1982.
- Lassaigne, Jacques. *Flemish Painting. Vol. 2. From Bosch to Rubens*. New York: Skira, 1958.
- Lavin, Marilyn Aronberg. *Piero della Francesca: San Francesco, Arezzo*. New York: George Braziller, 1994.
- _____. *The Place of Narrative: Mural Decoration in Italian Churches, 431-1600*. Chicago and London: University of Chicago Press, 1990.
- Lutze, Eberhard. *Veit Stoss*. Munich: Deutscher Kunstverlag, 1968.
- Macadam, Alta, ed. *Rome and Environs*. London: Benn, 1979.
- Marcucci, Luisa. *Gallerie nazionali di Firenze: i dipinti toscani del secolo XIV*. Rome: Istituto poligrafico dello Stato, 1965.
- Mariani, Valerio. *Michelangelo, the Painter*. Milan: Arti Grafiche Ricordi, 1964.
- Marle, Raimond van. *The Development of the Italian Schools of Painting. Vol. 9, Late Gothic Painting in Tuscany*. The Hague: Martinus Nijhoff, 1927.
- Martin, John Rupert. *The Farnese Gallery*. Princeton, N.J.: Princeton University Press, 1965.
- Martindale, Andrew. *Simone Martini*. Oxford: Phaidon, 1988.
- Mellini, Gian Lorenzo. *Altichiero e Jacopo Avanzi*. Milan: Edizioni di Comunita, 1965.
- _____. *Giovanni Pisano*. Milan: Electa, 1970.
- Mellinkoff, Ruth. *The Devil at Isenheim: Reflections of Popular Belief in Grunewald's Altarpiece*. Berkeley: University of California Press, 1988.
- Merot, Alain. *Nicolas Poussin*. New York: Abbeville Press, 1990.
- Micheletti, Emma. *Domenico Ghirlandaio*. Florence: Scala, 1990.
- Microsoft Art Gallery: The Collection of the National Gallery, London*. Redmond, Washington: Microsoft Corporation, 1993.
- Millon, Henry A., and Vittorio Magnago Lampugnani, eds. *The Renaissance from Brunelleschi to Michelangelo: The Representation of Architecture*. New York: Rizzoli, 1997.
- Moleta, Vincent. *From St. Francis to Giotto: The Influence of St. Francis on Early Italian Art and Literature*. Chicago: Franciscan Herald Press, 1983.
- Morassi, Antonio. *A Complete Catalogue of the Paintings of G. B. Tiepolo*. London: Phaidon Press, 1962.
- Moskowitz, Anita Fiderer. *The Sculpture of Andrea and Nino Pisano*. Cambridge: Cambridge University Press, 1986.
- Muraro, Michelangelo. *Paolo da Venezia*. University Park and London: Pennsylvania State University Press, 1970.
- Museo del Prado: inventario general de pinturas. Vol.1, La coleccion real*. Madrid: Museo del Prado, 1990.
- National Gallery of Art, Washington, DC*, www.nga.gov/home.html

- Offner, Richard. *A Critical and Historical Corpus of Florentine Paintings*. Section 3, *Fourteenth Century*. Vol. 3, *The Works of Bernardo Daddi*. New York: New York University Press, 1930.
- Padoa Rizzo, Anna. *Benozzo Gozzoli pittore fiorentino*. Florence: Edam, 1972.
- Pallucchini, Anna. *L'opera completa di Giambattista Tiepolo*. Milan: Rizzoli, 1968.
- Panofsky, Erwin. *Early Netherlandish Painting, Its Origins and Character*. 2 vols. Cambridge: Harvard University Press, 1966.
- Paolucci, Antonio. *Luca Signorelli*. Florence: Scala, 1990.
- Pedretti, Carlo. *Raphael: His Life and Work in the Splendors of the Italian Renaissance*. Florence: Giunti, 1989.
- Pettenella, Plinia. *Altichiero e la pittura Veronese del Trecento*. Verona: Edizioni di Vita Veronese, 1961.
- Pietrangeli, Carlo, et al. *The Sistine Chapel: The Art, the History and the Restoration*. New York: Harmony Books, 1986.
- Pignatti, Terisio. *L'opera completa di Giovanni Bellini detto Giambellino*. Milan: Rizzoli, 1969.
- Planiscig, Leo. *Luca della Robbia*. Vienna: Verlag Anton Schroll, 1940.
- Poeschke, Joachim. *Die Kirche San Francesco in Assisi und ihre Wandmalereien*. Translated by Russell Stockman. Munich: Hirmer Verlag, 1985.
- _____. *Donatello and his World: Sculpture of the Italian Renaissance*. New York: Harry N. Abrams, 1993.
- Poorter, Nora de. *The Eucharist Series*. 2 vols. London: Harvey Miller and Philadelphia: Heyden and Son, 1978.
- Pope-Hennessy, John W. *Donatello: Sculptor*. New York: Abbeville Press, 1993.
- _____. *Fra Angelico*. 2nd ed. Ithaca, New York: Cornell University Press, 1974.
- _____. *Giovanni di Paolo*. London: Chatto and Windus, 1937.
- _____. *Raphael: The Wrightsman Lectures*. London: Phaidon Press, 1970.
- Posner, Donald. *Annibale Carracci: A Study in the Reform of Italian Painting around 1590*. 2 vols. London: Phaidon Press, 1971.
- Previtali, Giovanni. *Giotto e la sua bottega*. 2nd ed. Milan: Fratelli Fabbri, 1967.
- Prinz, Wolfram, and Max Seidel, eds. *Domenico Ghirlandaio, 1449-1494: atti del convegno internazionale, Firenze, 16-18 ottobre 1994*. Florence: Centro Di, 1996.
- Puyvelde, Leo van. *Van Eyck: The Holy Lamb*. Paris: Marion Press, 1946.
- _____. *L'agneau mystique d'Hubert et Jean van Eyck*. Brussels: Elsevier, 1959.
- Quinlan-McGrath, Mary. "The Astrological Vault of the Villa Farnesina: Agostino Chigi's Rising Sign." *Journal of the Warburg and Courtauld Institutes* 47 (1984): 6-10.
- Raffaello in Vaticano: [mostra] Citta del Vaticano, Braccio di Carlo Magno, 16 ottobre 1984-16 gennaio 1985*. Milan: Electa, 1984.
- Rasmo, Nicolo. *Michael Pacher*. London, Phaidon Press, 1971.
- Redig de Campos, Deodocio, ed. *Art Treasures of the Vatican: Architecture, Painting, Sculpture*. Englewood Cliffs, New Jersey: Prentice Hall, 1974.
- Riess, Jonathan B. *Luca Signorelli: The San Brizio Chapel, Orvieto*. New York: George Braziller, 1995.

- Roettgen, Steffi. *Italian Frescoes*. Vol. 1, *The Early Renaissance, 1400-1470*; Vol. 2, *The Flowering of the Renaissance, 1470-1510*. Translated by Russell Stockman. New York, London and Paris: Abbeville Press, 1996-97.
- Roma e dintorni. 6th ed. Milan: T.C.I., 1965.
- Rowley, George. *Ambrogio Lorenzetti*. 2 vols. Princeton, N.J.: Princeton University Press, 1958.
- Ruf, Gerhard. *Das Grab des hl. Franziskus: die Fresken der Unterkirche von Assisi*. Freiburg im Breisgau: Herder, 1981.
- Salmi, Mario. *La pittura di Piero della Francesca*. Novara: Istituto geografico De Agostini, 1979.
- Salmi, Mario, et al. *The Complete Work of Raphael*. New York: Reynal and Co., 1969.
- Salvini, Roberto. *The Sistine Chapel*. 2 vols. New York: Harry N. Abrams, 1971.
- San Juan, Rose Marie. "The Illustrious Poets in Signorelli's Frescoes for the Cappella Nuova of Orvieto Cathedral." *Journal of the Warburg and Courtauld Institutes* 52 (1989): 71-84.
- San Paolo fuori le mura a Roma* Florence: Nardini, 1988.
- Santi, Bruno. *San Lorenzo: Guide to the Laurentian Complex*. Florence: Scala, 1992.
- Saxl, Fritz. *La fede astrologica di Agostino Chigi: interpretazione dei dipinti di Baldassare Peruzzi nella Sala di Galatea della Farnesina*. Rome: Reale Accademia d'Italia, 1934.
- Scarpellini, Pietro. *Perugino*. Milan: Electa, 1984.
- Scheja, Georg. *The Isenheim Altarpiece*. New York: Harry N. Abrams, 1969.
- Schneider, Laurie, ed. *Giotto in Perspective*. Englewood Cliffs, N.J.: Prentice Hall, 1974.
- Schultze, Jurgen. "Zur Kunst der 'Franziskusmeisters'." *Wallraf-Richartz Jahrbuch* 25 (1963): 109-150.
- Sello, Gottfried. *Veit Stoss*. Munich: Hirmer Verlag, 1988.
- Seymour, Charles. *Sculpture in Italy: 1400-1500*. Harmondsworth: Penguin Books, 1966.
- _____, ed. *Michelangelo: The Sistine Chapel Ceiling*. New York: Norton, 1972.
- Shearman, John. *Raphael's Cartoons in the Collection of Her Majesty the Queen and the Tapestries for the Sistine Chapel*. London: Phaidon Press, 1972.
- Snyder, James. *Northern Renaissance Art: Painting, Sculpture, the Graphic Arts from 1350-1575*. New York: Harry N. Abrams, 1985.
- Sonnenburg, Hubertus von. *Raphael in der Alten Pinakothek: Geschichte und Wiederherstellung des ersten Raphael-Gemaldes in Deutschland und der von König Ludwig I. erworbenen Madonnenbilder*. Munich: Prestel-Verlag, 1983.
- Starn, Randolph. *Ambrogio Lorenzetti: The Palazzo Pubblico, Siena*. New York: George Braziller, 1994.
- Steinmann, Ernst. *Ghirlandaio*. Bielefeld and Leipzig: Velhagen and Klasing, 1897.
- Strieder, Peter. *Albrecht Durer, Paintings, Prints, Drawings*. Rev. ed. New York: Abaris Books, 1989.
- Tintori, Leonetto, and Eve Borsook. *Giotto: The Peruzzi Chapel*. New York: Harry N. Abrams, 1965.
- Toesca, Elena Berti. *Benozzo Gozzoli: gli affreschi della cappella medicea*. Milan: Amilcare Pizzi, 1958.
- Turner, Jane, ed. *The Dictionary of Art*. 34 vols. New York: Grove Dictionaries, 1996.
- Venturi, Adolfo. *Giovanni Pisano: sein Leben und sein Werk*. Vol.1. Florence: Pantheon, 1927.

- Verdi, Richard. *Nicolas Poussin, 1594-1665*. London: Royal Academy of Arts, 1995.
- Volpe, Carlo. *Pietro Lorenzetti*. Milan: Electa, 1989.
- Wehle, Harry Brandeis. *Great Paintings from the Prado Museum*. New York: Harry N. Abrams, 1963.
- White, John. *Art and Architecture in Italy, 1250-1400*. 1st ed. Harmondsworth, Middlesex: Penguin Books, 1966.
- _____. *Art and Architecture in Italy, 1250-1400*. 2nd ed. Harmondsworth, Middlesex: Penguin Books, 1987.
- _____. *Duccio: Tuscan Art and the Medieval Workshop*. London: Thames and Hudson, 1979.
- Wilkins, David G. *Maso di Banco: A Florentine Artist of the Early Trecento*. New York: Garland, 1985.
- Zampetti, Pietro. *Carlo Crivelli*. Florence, Nardini, 1986.
- Zampetti, Pietro, and Giampiero Donnini. *Gentile e i pittori di Fabriano*. Florence: Nardini, 1992.
- Zervas, Diane Finiello, ed. *Orsanmichele a Firenze*. 2 vols. Modena: F.C. Panini, 1996.

INDEX

- Adoration of the Magi Triptych*, (Bosch), 17
Adoration of the Magi (Strozzi Altarpiece), (Gentile da Fabriano), 40
Albizzo di Piero, *Guild Niches and Exterior Sculpture*, Orsanmichele, 28
Allegory of Good and Bad Government, (Lorenzetti, Ambrogio), 61
Allori, Alessandro, *Salon Frescoes*, 1
Altarpiece of Blessed Humility, (Lorenzetti, Pietro), 63
Altarpiece of Jean des Trompes (Baptism Altarpiece), (David), 25
Altarpiece of the Adoration of the Magi, Bruges, (Memling), 78
Altarpiece of the Adoration of the Magi, Madrid, (Memling) 79
Altarpiece of the Crucifixion, (Memling), 80
Altarpiece of the Holy Sacraments, (Bouts), 18
Altarpiece of the Seven Sorrows of the Virgin, (Durer), 31
Altarpiece of the Two St. Johns, (Memling), 81
Altarpiece of the Virgin, (Weyden, Rogier van der), 118
Altarpiece of the Virgin Enthroned (John Donne Triptych), (Memling), 82
Altarpiece of St. Anthony, (Piero della Francesca), 94
Altarpiece of St. Louis of Toulouse, (Martini, Simone), 71
Altarpiece of William Moreel (St. Christopher Triptych), (Memling), 83
Altdorfer, Albrecht, *St. Sebastian Altarpiece*, 2
Altichiero, *Scenes from the Lives of St. Lucy, St. George, and the New Testament*, 3
Andrea da Firenze (Andrea Bonaiuti), *Spanish Chapel*, 4
Andrea del Sarto, *Salon Frescoes*, 1
Angelico, Fra, *Annunciation*, 5; *Linaiuoli Triptych*, 7; *Lives of St. Stephen and St. Lawrence*, 6; *Madonna and Child with Saints (Pala di San Marco)*, 8; *Perugia Altarpiece*, 9; *San Brizio Chapel Frescoes*, 113
Annunciation, (Angelico, Fra), 5
Arena Chapel, (Giotto), 46
Arezzo Polyptych, (Lorenzetti, Pietro), 64
Ascoli Piceno Polyptych, (Crivelli), 22
Assumption of the Virgin with Saints (Staggia Altarpiece), (Giovanni di Paolo), 52
Astrological Frescoes, (Peruzzi), 91
Baccio da Montelupe, *Guild Niches and Exterior Sculpture*, 28
Baldung Grien, Hans, *Freiburg Altarpiece*, 11
Bamberg Altarpiece, (Stoss, Veit), 114
Baptism Altarpiece (Altarpiece of Jean des Trompes), (David), 25
Bardi Chapel, (Giotto), 47
Barna da Siena, *Life of Christ*, 12
Baroncelli Chapel, (Taddeo Gaddi), 36 -37
Beaune Altarpiece (Triptych of the Last Judgement), (Weyden, Roger van der), 119
Beccafumi, Domenico, *Sala del Concistoro Vault*, 13
Bellini, Giovanni, *Pesaro Altarpiece (Coronation of the Virgin)*, 14; *Polyptych of St. Vincent Ferrer*, 15
Bicci di Lorenzo, *Legend of the True Cross*, 92
Boulogne, Jean (Giambologna), *Guild Niches and Exterior Sculpture*, Orsanmichele, 28
Bonanus of Pisa, *Porta di San Ranieri*, 16
Bonaiuti, Andrea, (Andrea da Firenze), 4
Bosch, Hieronymus, *Adoration of the Magi Triptych*, 17

- Botticelli, Sandro**, *Lower Walls*, Sistine Chapel, **117**
Bouts, Dirk, *Altarpiece of the Holy Sacrament*, **18**
Brancacci Chapel Frescoes, (Masaccio), **74**
Bromley-Davenport Altarpiece, (Gaddi, Taddeo, Attributed), **38**
Bronze Doors, San Paolo fuori le mura, **109**
Bronze Doors and Stucco Reliefs, San Lorenzo, (Donatello and Michelozzo di Bartolomeo), **26**
Bronze Pulpits, San Lorenzo, (Donatello), **27**
Campin, Robert, see **Flemalle, Master of**
Campanile Hexagonal Reliefs, Florence, (Pisano, Andrea and Luca della Robbia), **95**
Cantoria, (Robbia, Luca della), **108**
Cappella Tornabuoni, (Ghirlandaio), **44**
Carlo di San Lazzaro di Narni, *Lives of St. Stephen and St. Lawrence*, **6**
Carmine Altarpiece, (Lorenzetti, Pietro), **62**
Carracci, Annibale, *Galleria Ceiling*, Palazzo Farnese, **19**
Castagno, Andrea del, *Christ's Passion*, **20**
Cathedral, Pisa, Porta di San Ranieri (Bonanus of Pisa), **16**; *Pulpit*, (Pisano, Giovanni), **97**
Ceiling Frescoes, Palazzo Clerici, Milan, (Tiepolo); **116** Sistine Chapel, (Michelangelo), **86**
Checha, Giovanni Antonio della, *Scenes from the Lives of St. Stephen and St. Lawrence*, **6**
Christ's Passion, (Castagno), **20**
Cimabue, *Upper Church*, San Francesco, **21**
Colle, Raffaellino del, *Sala di Constantino*, **53**
Coronation of the Virgin Altarpiece, (Lorenzo Monaco), **66**
Crivelli, Carlo, *Polyptych of Ascoli Piceno*, **22**
Daddi, Bernardo, *Fragmentary Predella with Seven Scenes from the Legend of The Holy Girdle*, **24**; *Polyptych in Seven Leaves*, **23**
David, Gerard, *Baptism Altarpiece (Altarpiece of Jean des Trompes)*, **25**
Della Robbia, Andrea, *Guild Niches and Exterior Sculpture*, Orsanmichele, **28**
Della Robbia, Luca, *Campanile Hexagonal Reliefs*, Florence, **95**; *Cantoria*, **108**; *Guild Niches and Exterior Sculpture*, Orsanmichele, **28**
Deposition Altarpiece, (Metsys), **85**
Donatello, *Bronze Doors and Stucco Reliefs*, San Lorenzo, **26**; *Bronze Pulpits*, San Lorenzo, **27**; *Guild Niches and Exterior Sculpture*, Orsanmichele, **28**
Duccio di Buoninsegna, *Maesta*, **29-30**
Durer, Albrecht, *Altarpiece of Seven Sorrows of the Virgin*, **31**
Eyck, Jan van and Hubert van Eyck, *Ghent Altarpiece*, **32**
Feo, Fra Diamante di, *Legends of St. Stephen and St. John the Baptist*, **60**
Flemalle, Master of (Robert Campin), *Merode Altarpiece*, **33**; *Von Werl Altarpiece*, **34**
Florence, Cathedral, Baptistry, Gates of Paradise, East Doors, (Ghiberti), **42**; *North Doors*, (Ghiberti), **43**; *South Doors*, (Pisano, Andrea), **96**; Orsanmichele, *Guild Niches and Exterior Sculpture*, **28**
Franciabigio, *Salon Frescoes, The*, **1**
Fragmentary Predella with Seven Scenes from the Legend of the Holy Girdle (Daddi, Bernardo), **24**
Freiburg Altarpiece, (Baldung Grien, Hans), **11**
Fresco, Santa Croce, (Gaddi, Taddeo), **39**
Frescoes, Brancacci Chapel (Masaccio, Masolino, and Filippo Lippi), **74**; *Chapel of St. Martin, San Francesco*, (Martini, Simone), **72**, *Baroncelli*

- Chapel*, (Gaddi, Taddeo) **36-37**; Lower Church, San Francesco, (Lorenzetti, Pietro), **65**; Sistine Chapel, (Michelangelo), **86**
- Gaddi, Agnolo**, *Legend of the True Cross*, **35**
- Gaddi, Taddeo**, *Baroncelli Chapel*, **36-37**; *Bromley-Davenport Altarpiece*, **38**; *Refectory*, **39**
- Galleria Ceiling*, Palazzo Farnese, (Carracci, Annibale), **19**
- Gates of Paradise (East Doors)*, (Ghiberti), **42**
- Gentile da Fabriano**, *Adoration of the Magi (Strozzi Altarpiece)*, **40**; *Valle Romita Altarpiece*, **41**
- Ghent Altarpiece*, (Eyck, Jan van and Hubert van Eyck), **32**
- Ghiberti, Lorenzo**, *Gates of Paradise, (East Doors)*, Baptistry, Florence, **42**; *Guild Niches and Exterior Sculpture*, Orsanmichele, **28**; *North Doors*, Baptistry, Florence, **43**
- Ghirlandajo, Domenico**, *Cappella Tornabuoni*, **44**; *Sasseti Chapel*, **45**; *Lower Walls*, Sistine Chapel, **117**
- Giambologna** see **Jean Boulogne**
- Giotto**, *Arena Chapel*, **46**; *Bardi Chapel*, **47**; *Legend of St. Francis, Old and New Testament Cycles*, **49**; *Peruzzi Chapel*, **48**; *St. Francis Series*, **50**
- Giovanni Antonio della Checha**, *Lives of St. Stephen and St. Lawrence*, **6**
- Giovanni da Venezia**, *Pala d'Oro Cover*, **89**
- Giovanni di Paolo**, *Assumption of the Virgin with Saints (Staggia Altarpiece)*, **52**; *Presentation in the Temple*, **51**
- Giulio Romano**, *Sala di Constantino*, **53**; *Sala di Psyche Ceiling*, **54**
- Goes, Hugo van der**, *Portinari Altarpiece*, **55**
- Gozzoli, Benozzo**, *Lives of St. Stephen and St. Lawrence*, **6**; *Procession of the Magi*, **57**; *Scenes from the Life of St. Francis, St. Francis in Glory, Franciscan Saints*, **56**
- Granada Altarpiece (Mary Altarpiece)*, (Weyden, Rogier van der), **118**
- Grunewald, Matthias**, *Isenheim Altarpiece*, **58**
- Guild Niches and Exterior Sculpture*, Orsanmichele, **28**
- Hagenau, Nicolas**, *Isenheim Altarpiece*, **58**
- Heemskerck, Maertin van**, *Saint Lawrence Altarpiece*, **59**
- Isenheim Altarpiece*, (Grunewald and Nicolas Hagenau), **58**
- Jacopo di Piero Guidi**, *Guild Niches and Exterior Sculpture*, Orsanmichele, **28**
- John Donne Triptych (Adoration of the Virgin Enthroned)*, (Memling), **82**
- Kracow Altarpiece*, (Stoss, Veit), **115**
- Lamberti, Michele**, *Guild Niches and Exterior Sculpture*, Orsanmichele, **28**
- Last Judgement*, (Michelangelo), **87**
- Legend of St. Francis*, (Giotto), **49**
- Legend of St. Francis, Old and New Testament Cycles*, (Giotto), **49**
- Legend of the Holy Girdle*, (Daddi, Bernardo), **24**
- Legend of the True Cross*, (Gaddi, Agnolo), **35**
- Legend of the True Cross*, (Piero della Francesca and Bicci di Lorenzo), **92**
- Legends of St. Stephen and St. John the Baptist*, (Lippi, Fra Filippo), **60**
- Leo X Vatican Tapestries Series*, (Raphael), **100**
- Life of Christ*, (Barna da Siena), **12**
- Life of St. Sylvester*, (Maso di Banco), **76**
- Linaiuoli Triptych*, (Angelico, Fra), **7**
- Lippi, Fra Filippo**, *Frescoes*, Brancacci Chapel, **74**; *Legends of St. Stephen and St. John the Baptist*, **60**
- Lives of St. Lucy, St. George and the New Testament*, (Altichiero), **3**
- Lives of St. Stephen and St. Lawrence*, (Angelico, Fra), **6**
- Loggia of Psyche*, (Raphael), **103**
- Lorenzetti, Ambrogio**, *Allegory of Good and Bad Government*, **61**

- Lorenzetti, Pietro**, *Altarpiece of Blessed Humility*, 63; *Arezzo Polyptych*, 64;
Carmine Altarpiece, 62; *Frescoes*, Lower Church, San Francesco, 65
- Lorenzo, Monaco**, *Coronation of the Virgin Altarpiece*, 66
- Lorenzo di Giovanni d'Ambrogio**, *Guild Niches and Exterior Sculpture*,
 Orsanmichele, 28
- Lotto, Lorenzo**, *Recanati Polyptych*, 67; *St. Stephen Altarpiece*, 68
Lower Church, San Francesco, Chapel of St. Martin, (Martini, Simone), 76
Lower Walls, Sistine Chapel, 117
- Luca da Venezia**, *Pala d'Oro Cover*, 89
Madonna and Child with Saints (Pala di San Marco), (Angelico, Fra), 8
Madonna's, (Raphael), 101-102
Maesta, (Duccio di Buoninsegna), 29 -30
Maesta, Siena, (Martini, Simone), 73
- Mantegna, Andrea**, *Ovetari Chapel Frescoes*, 69; *Polyptych of St. Luke*, 70
Marriage Feast of Cupid and Psyche, (Raphael), 103
- Martini, Simone**, *Altarpiece of St. Louis of Toulouse*, 71; *Lower Church*, Chapel
 of St. Martin, San Francesco, 72; *Maesta*, 73
- Mary Altarpiece (Granada Altarpiece)*, (Weyden, Roger van der), 118
- Masaccio**, *Frescoes*, Brancacci Chapel, 74; *Pisa Altarpiece*, 75
- Maso di Banco**, *Life of Sylvester*, 76
- Masolino**, *Frescoes*, Brancacci Chapel, 74
- Master of the Bardi Altarpiece**, *St. Francis and Scenes from his Legend*, 77
- Matteo da Lecce**, *Lower Walls*, Sistine Chapel, 117
- Memling, Hans**, *Altarpiece of the Adoration of the Magi*, Bruges, 78; *Altarpiece
 of the Adoration of the Magi*, Madrid, 79; *Altarpiece of the Crucifixion*, 80;
Altarpiece of the Two St. Johns, 81; *Altarpiece of the Virgin Enthroned (John
 Donne Triptych)*, 82; *St. Christopher Triptych (Altarpiece of William
 Moreel)*, 83; *Shrine of St. Ursula*, 84
- Merode Altarpiece*, (Campin, Robert) (Master of Flemalle), 33
- Metsys, Quinten**, *Deposition Altarpiece*, 85
- Michelangelo**, *Ceiling Frescoes*, Sistine Chapel, 86; *Last Judgement*, 87
- Michelozzo di Bartolomeo**, *Bronze Doors and Stucco Reliefs*, San Lorenzo, 26;
Guild Niches and Exterior Sculpture, 28
- Misericordia Polyptych*, (Piero della Francesca), 93
- Nanni di Banco**, *Guild Niches and Exterior Sculpture*, Orsanmichele, 28
- Narni, Carlo de San Lazzaro da**, *Scenes from the Lives of St. Stephen and St.
 Lawrence*, 6
- Niccolo di Pietro Lamberti**, *Guild Niches and Exterior Sculpture*, Orsanmichele,
 28
- North Doors*, Baptistry, Florence, (Ghiberti, Lorenzo), 43
Old Testament Subjects (Raphael's Bible), (Raphael), 104
Ovetari Chapel Frescoes, (Mantegna, Andrea), 69
- Pacher, Michael**, *St. Wolfgang Altarpiece*, 88
Pala d'Oro Cover, (Paolo da Venezia), 89
Pala di San Marco (Madona and Child with Saints), (Angelico, Fra), 8
- Palazzo Pubblico**, Siena, *Allegory of Good and Bad Government*, (Lorenzetti), 61;
Maesta, (Martini), 73 *Sala del Concistoro Vault*, (Beccafumi), 13
- Paolo da Venezia**, *Pala d'Oro Cover*, 89; *Polyptych with St. Clare*, 90
Passion Cycle (San Francesco Master, Attributed to), 10
- Penni, Giovanni Francesco**, *Sala di Constantino*, 53; *Sala di Psyche Ceiling*, 54
- Perfetto di Giovanni**, *Guild Niches and Exterior Sculpture*, Orsanmichele, 28
Perugia Altarpiece, (Angelico, Fra), 9
- Perugino, Pietro**, *Lower Walls*, Sistine Chapel, 117
- Peruzzi, Baldassare**, *Astrological Frescoes*, Villa Farnesina, 91

- Peruzzi Chapel*, (Giotto), **48**
Pesaro Altarpiece (Coronation of the Virgin), (Bellini, Giovanni), **14**
Piero della Francesca, *Legend of the True Cross*, **92**; *Polyptych of the Misericordia*, **93**; *Saint Anthony Altarpiece*, **94**
Pietro d'Antonio da Poli, *Lives of St. Stephen and St. Lawrence*, **6**
Pisa Altarpiece, (Masaccio), **75**
Pisano, Andrea, *Campanile Hexagonal Reliefs*, Florence, **95**; *South Doors*, Baptistry, Florence, **96**
Pisano, Giovanni, *Pulpit*, Cathedral, Pisa, **97**; *Pulpit of Pistoia*, **98**
Poli, Pietro d'Antonio da, *Scenes from the Lives of St. Stephen and St. Lawrence*, **6**
Polyptych in Seven Leaves, (Daddi, Bernardo), **23**
Polyptych in Ten Panels, (Schiavone, Giorgio), **112**
Polyptych of Ascoli Piceno, (Crivelli, Carlo), **22**
Polyptych of St. Luke, (Mantegna, Andrea), **70**
Polyptych of St. Vincent Ferrer, (Bellini, Giovanni), **15**
Polyptych of the Misericordia, (Piero della Francesca), **93**
Polyptych with St. Clare, (Paola da Venezia), **90**
Pontormo, Jacopo, *Salon Frescoes*, **1**
Porta di San Ranieri (Bonanus of Pisa), **18**
Portinari Altarpiece, (Goes, Hugo van der), **55**
Poussin, Nicolas, *Sacraments*, **99**
Presentation in the Temple, (Giovanni di Paolo), **51**
Procession of the Magi, (Gozzoli, Benozzo), **57**
Pulpit, Cathedral, Pisa, (Pisano, Giovanni), **97**
Pulpit of Pistoia, (Pisano, Giovanni), **98**
Pulpits, San Lorenzo, (Donatello), **27**
Raphael, *Leo X Vatican Tapestries Series*, **100**; *Madonnas*, **101-102**; *Marriage Feast of Cupid and Psyche*, **103**; *Old Testament Subjects (Raphael's Bible)*, **104**; *Stanzas*, **105**; *Stufetta of Cardinal Bibbiena*, **106**
Recanati Polyptych, (Lotto, Lorenzo), **67**
Ricci, Sebastiano, *Room of Hercules Frescoes (Sala d'Ercole)*, **107**
Robbia, Andrea della, see **Della Robbia, Andrea**
Robbia, Luca della, *Cantoria*, **108**; see also **Della Robbia, Luca**
Rome, Bronze Doors, San Paolo fuori la mura, **109**
Room of Hercules Frescoes (Sala d'Ercole), (Ricci), **107**
Rosselli, Pietro di Giacomo, *Lower Walls*, Sistine Chapel, **117**
Rubens, Peter Paul, *Triumph of the Eucharist Series and Related Works*, *The*, **110-111**
St. Anthony Altarpiece, (Piero della Francesca), **94**
St. Christopher Triptych (Altarpiece of William Moreel), (Memling), **83**
St. Francis and Scenes from His Legend, (Master of the Bardi Altarpiece), **77**
St. Francis Series, (Giotto), **50**
St. Lawrence Altarpiece, (Heemskerck, Maertin van), **59**
St. Sebastian Altarpiece (Altdorfer), **2**
St. Stephen Altarpiece, (Lotto, Lorenzo), **68**
St. Wolfgang Altarpiece, (Pacher), **88**
Sacraments, (Poussin), **99**
Saint Anthony Altarpiece, (Piero della Francesca), **94**
Sala d'Ercole, (Ricci, Sebastiano), **107**
Sala del Concistoro Vault (Beccafumi, Domenico), **13**
Sala di Constantino, (Giulio Romano, Giovanni Francesco Penni, and Raffaellino del Colle), **53**
Sala di Psyche Ceiling, (Giulio Romano), **54**

- Salon Frescoes, The*, (Allori; Andrea del Sarto; Franciabigio; Pontormo), **1**
San Brizio Chapel Frescoes, (Signorelli and Fra Angelico), **113**
San Francesco Master, Attributed to, Passion Cycle, **10**
San Pancrazio Polyptych in Seven Leaves, (Daddi, Bernardo), **23**
Sasseti Chapel, (Ghirlandaio), **45**
Scenes from the Life of St. Francis, St. Francis in Glory, Franciscan Saints,
 (Gozzoli, Benozzo), **56**
Scenes from the Lives of St. Lucy, St. George and the New Testament, (Altichiero),
3
Schiavone, Giorgio, Polyptych in Ten Panels, **112**
Shrine of St. Ursula, (Memling), **84**
Signorelli, Luca, Lower Walls, Sistine Chapel, **117**; *San Brizio Chapel Frescoes*,
113
Sistine Chapel Ceiling Frescoes, (Michelangelo), **87**
South Doors, Baptistry, Florence, (Pisano, Andrea), **96**
Spanish Chapel, Andrea da Firenze (Andrea Bonaiuti), **4**
Staggia Altarpiece (Assumption of the Virgin with Saints), (Giovanni di Paolo), **52**
Stanzas, (Raphael), **105**
Stoss, Veit, Bamberg Altarpiece, **114**; *Kracow Altarpiece*, **115**
Strozzi Altarpiece (Adoration of the Magi), (Gentile da Fabriano), **40**
Stuffetta of Cardinal Bibbiena, Vatican City, (Raphael), **106**
Talenti, Simone, Guild Niches and Exterior Sculpture, Orsanmichele, **28**
Tiepolo, Giovanni Battista, Ceiling Frescoes, Palazzo Clerici, Milan, **116**
Tornabuoni Chapel, (Ghirlandaio), **44**
Triptych of John Donne, (Altarpiece of the Virgin Enthroned), (Memling, Hans),
82
Triptych of St. Christopher, (Memling, Hans), **83**
Triptych of the Last Judgement, (Beaune Altarpiece), (Weyden, Roger van der),
119
Triumph of the Eucharist Series and Related Works, The (Rubens), **110-111**
Trompes, Jean de Altarpiece, (David, Gerard), **25**
Upper Church, San Francesco, (Cimabue), **21**; *Legend of St. Francis* (Giotto), **49**
Valle Romita Altarpiece, (Gentile da Fabriano), **41**
Van den Broeck, Hendrick, Lower Walls, Sistine Chapel, **117**
Von Werl Altarpiece, (Flemalle, Master of), (Campin, Robert), **34**
Weyden, Rogier van der, Mary Altarpiece (Granada Altarpiece), **118**; *Triptych*
of the Last Judgement (Beaune Altarpiece), **119**